

March 2009

## **COWRIE 2.0 Electromagnetic Fields (EMF) Phase 2**

EMF-sensitive fish response to EM emissions from sub-sea electricity cables of the type used by the offshore renewable energy industry

Contract No.: COWRIE-EMF-1-06  
Ref: EP-2054-ABG

### **COWRIE 2.0 EMF Final Report**

Andrew B Gill  
Yi Huang  
Ian Gloyne-Philips  
Julian Metcalfe  
Victoria Quayle  
Joe Spencer  
Victoria Wearmouth

COWRIE 2.0 Electromagnetic Fields (EMF) Phase 2 was a collaborative project between Cranfield University, Centre for Fisheries, Environment and Aquaculture Science (CEFAS), CIMS Centre for Intelligent Monitoring Systems, University of Liverpool & Centre for Marine and Coastal Studies Ltd

© COWRIE Ltd, 2009

Published by COWRIE Ltd.

This publication (excluding the logos) may be re-used free of charge in any format or medium. It may only be re-used accurately and not in a misleading context. The material must be acknowledged as COWRIE Ltd copyright and use of it must give the title of the source publication. Where third party copyright material has been identified, further use of that material requires permission from the copyright holders concerned.

ISBN: 978-0-9561404-1-8

Preferred way to cite this report:

Gill, A.B., Huang, Y., Gloyne-Philips, I., Metcalfe, J., Quayle, V., Spencer, J. & Wearmouth, V. (2009). COWRIE 2.0 Electromagnetic Fields (EMF) Phase 2: EMF-sensitive fish response to EM emissions from sub-sea electricity cables of the type used by the offshore renewable energy industry. Commissioned by COWRIE Ltd (project reference COWRIE-EMF-1-06).

Copies available from:

[www.offshorewind.co.uk](http://www.offshorewind.co.uk)

E-mail: [cowrie@offshorewind.co.uk](mailto:cowrie@offshorewind.co.uk)

*Contact details:*

Andrew B Gill  
Integrated Environmental Systems Institute  
Natural Resources Department  
Building 37  
School of Applied Sciences  
Cranfield University  
MK43 0AL  
UK

Tel: +44(0)1234 750111 x2711

Fax: +44(0)1234 752971

E-mail: [a.b.gill@cranfield.ac.uk](mailto:a.b.gill@cranfield.ac.uk)

## Contents

<b>Section 1 – Management Report</b> .....	3
1. Project Objective.....	3
2. Summary of Scientific and Technical Achievements .....	3
3. Project Deliverables.....	3
4. Assessment of Project Achievements.....	4
5. Resource Use.....	4
6. Deviation from Resource Use .....	6
7. Conclusions .....	6
8. Recommendations.....	6
<b>Section 2 – Technical Report</b> .....	8
1. Executive Summary.....	8
2. Non-technical Summary .....	12
3. Background.....	14
4. Project Objective.....	14
5. Project Methodology .....	15
5.1. Study Location .....	15
5.2. Experimental Mesocosms.....	16
5.3. Electromagnetic Field (EMF) Production.....	16
5.3.1. Electromagnetic Field (EMF) Measurement .....	17
5.4. Environmental variables.....	18
5.5. Experimental Design.....	19
5.6. Study Species .....	19
5.7. VRAP Acoustic Tracking.....	21
5.8. Data storage tags.....	22
5.9. VRAP Data Processing.....	22
6. Project Data Analysis and Results.....	24
6.1. Notes on statistical procedures.....	24
6.2. VRAP data analysis .....	24
7. Assessing the significance of mesocosm study results .....	43
8. EMF Measurements at Operational Wind Farms.....	44
8.1. Overview .....	44
8.2. Offshore Wind Farm Sites.....	46
8.3. Methods .....	48
8.4. EMF Measurements and comparison with Mesocosm Study.....	50
8.4.1. Ardtoe Mesocosm EMFs .....	50
8.4.2. Burbo Bank Wind Farm .....	52
8.4.3. North Hoyle Wind Farm .....	57
8.4.4. A note on Cable Burial Depth .....	61
8.5. Conclusions .....	62
9. Project Conclusions .....	63
10. Recommendations .....	64
11. Acknowledgements .....	66
12. References.....	67
13. Appendices .....	68

# Section 1 – Management Report

## 1. Project Objective

The Environmental Technical Working Group (ETWG) of COWRIE commissioned the priority research project COWRIE 2.0 EMF with the objective to determine if electromagnetic sensitive fish respond to controlled electromagnetic fields (EMF) with the characteristics and magnitude of EMF associated with offshore wind farm power cables.

The project was undertaken by a consortium with representatives from Cranfield University (Project Coordinators), Centre for Marine and Coastal Studies Ltd (CMACS), Centre for Fisheries, Environment and Aquaculture Science (CEFAS) and Centre for Intelligent Monitoring Systems (CIMS), University of Liverpool.

The project took an experimental research approach by enclosing a section of sub-sea cable within a suitable area of seabed using an approach known as 'mesocosm studies' to allow the response of elasmobranch test species to controlled electromagnetic fields to be assessed within a semi-natural setting. Prior to the study and following peer-review of the project design it had been agreed with members of COWRIE that the mesocosm approach would be the best option for obtaining scientifically rigorous information required to answer the primary research question:

- Do electromagnetically (EM) sensitive organisms respond to anthropogenic EMFs of the type and magnitude generated by offshore wind farms?

Answering this question is an important first stage before needing to consider whether any effects of EMF may be positive or negative? The focus of our study and this report was therefore on addressing the primary objective, which will then be of value for further consideration of potential effects.

The study was conducted under controlled research conditions but to improve its applicability to the actual situation found at a wind farm the mesocosm experiment took place in a shallow, sheltered coastal water location. The study used acoustic telemetry technology, to detect the real-time movements of individually identifiable fish within a mesocosm in relation to an energised section of sub-sea electricity cable. A second mesocosm without the cable energised was used as a reference.

Here, the consortium presents the final report to the Programme Management at Nature Bureau and the COWRIE Board, detailing the findings of the research project COWRIE 2.0 EMF. The report is in two sections with a management overview in Section 1 and the majority of the material relating to the study within Section 2 which covers the technical aspects.

*Note*, some parts of this final report refer to documents produced during the course of the research project, namely: COWRIE 2.0 EMF Phase 2 Project Plan Update, First, Second and Third Quarterly Interim Reports and First and Second Progress Reports. These reports are held by COWRIE.

## 2. Summary of Scientific and Technical Achievements

We undertook a research project which met the primary objective set out in the COWRIE 2.0 EMF Phase 2 project specification. The study has provided the first ever evidence of EMF-sensitive fish response to EM emissions from sub-sea, electricity cables of the type used by the offshore renewable energy industry.

## 3. Project Deliverables

In addition to the deliverables detailed in the COWRIE 2.0 EMF Phase 2 Project Plan Update, First, Second and Third Quarterly Interim Reports and First and Second Progress Reports,

we conducted a hierarchical analysis and assessment of the data collected. We also ensured that any requirements of licences and permissions were been met. Finally, we provided the final report for the current project.

## 4. Assessment of Project Achievements

The collaborative team are satisfied that the study has met the primary objective of the project. Overall this unique project was extremely challenging, which resulted in a number of delays. The delays and associated overspend provide some very useful lessons for future projects of this type and scale. Regardless, the outcome has provided essential, scientifically rigorous determination of a topic that has been discussed for a number of years since wind power has been developed in coastal waters around the world. The results of the study are a significant step forward in our understanding of one of the environmental implications of developing offshore wind farms. The results will be of interest worldwide and are applicable to other types of offshore renewable energies.

## 5. Resource Use

In general, the project was successful from a scientific perspective; however, the whole project was overspent. Table 1 shows a summary of expenditure compared against budget. More detail on the financial aspects of the project is available on request. The main overspend related to the manpower, sub-contracting and salaries primarily as a result of revised pay scales and extra work coming from project delays. Some overspend was related to materials and development of the novel equipment used in the project.

During the project the following resources have been used:

### ***Summary of project spend:***

Project budget = **£ 336542**

Materials and technical support	£ 240810
Manpower/salaries	£ 69186
Sub-contractors	£ 45185
T & S	£ 5751
Miscellaneous	£ 714
Decommissioning/maintenance/insurance	<u>£ 20438*</u>
<b>Total</b>	<b><u>£ 382084</u></b>

\* = committed budget

Whilst the project was overspent, the remaining budget under the sub-contractor heading has been allocated to maintenance of the mesocosms and tracking/recording equipment, including insurance cover and decommissioning. As the main contractors, Cranfield University has committed funds to cover this overspend.



## 6. Deviation from Resource Use

When considering the whole project there was extra work and delays owing to organisational procedures and processes, procurement and provision of services. These were not unexpected but the unique nature of the COWRIE 2.0 EMF project meant that the deviation from resource use was at times greater than expected.

The COWRIE 2.0 EMF Phase 2 Project Plan Update, First, Second and Third Quarterly Interim Reports and First and Second Progress Reports all cover any deviations from resource use in detail. Since the last Interim Report the deviation has been related to the timing of final report submission. The data collation, sorting, and analysis and the reporting were originally planned to be undertaken by the post-doctoral officer employed through the project. However, as a consequence of the delays that were encountered during the project the year long post-doctoral post came to an end before the bulk of the analysis could be undertaken. The result was that the remaining members of the team have had to allocate time that they did not originally budget for in the subsequent. The draft final report was subject to a prolonged industry and peer review and dealing with the comments added further delays to production of the final report.

## 7. Conclusions

COWRIE 2.0 EMF was commissioned to meet the objective of determining whether electrosensitive fish respond to the EMF emitted by sub-sea cables of the type and intensity associated with offshore wind farm cables. The project met the objective by demonstrating that some electrosensitive elasmobranchs responded to the EMF emitted in terms of both the overall spatial distribution of one of the species tested and at the finer scale level of individual fish of different species.

Furthermore, the field measuring of EMF at offshore wind farms sites showed that there are both magnetic and electric field emissions associated with the main feeder cables to shore and these EM fields were comparable with the EM field produced in the experimental mesocosm study, and in some cases of greater intensity.

Considering the novelty, the enormity of the logistics and the uniqueness of the project we are satisfied that the experimental phase of the project has been completed successfully and addressed the main objective set out in the COWRIE 2.0 EMF project specification.

## 8. Recommendations

Whilst the mesocosm project demonstrated some responses by the elasmobranchs to the EMFs and the field survey provided evidence that the EM fields previously predicted to be emitted do exist there is a requirement to be objective in the assessment of the findings when considering recommendations that can be made.

There is no evidence from the present study to suggest any positive or negative effect on elasmobranchs of the EMF encountered. This can only be determined through further specific studies with clearly defined objectives and also monitoring at offshore wind farm sites with appropriate analysis over time. Suggestions for this type of monitoring programme were included in the COWRIE 1.5 EMF report

[http://www.offshorewindfarms.co.uk/Assets/1351\\_emf\\_phase\\_one\\_half\\_report.pdf](http://www.offshorewindfarms.co.uk/Assets/1351_emf_phase_one_half_report.pdf) .

Research of the type and scale highlighted in the current report would reduce the time frame for understanding any effects by helping target species for monitoring. Targetted monitoring would be considerably cheaper than a catch-all comprehensive fishery survey to determine changes in numbers, demographics of populations and recruitment. Hence, the value of this report is the potential contribution to the design of monitoring procedures for these effects, and providing a base for further research

### *Experimental EMF Studies*

The mesocosm study used a limited number of species and also one EMF emission intensity, which was towards the lower end of the range of detection for the elasmobranchs. Future work should focus on widening the EMF intensities encountered by the EM sensitive species and take into account the EMF variability such as that measured at the wind farm sites.

Furthermore, there should be consideration of the potential response of other life stages (embryos and juveniles) to the EMFs present as they have different sensitivity ranges to adult elasmobranchs and they are often associated with the shallow, sandy environments that many of the wind farms are located within. By determining whether other life stages respond and to what degree will provide further evidence for target monitoring at specific species life stages.

### *Mesocosms*

In terms of the mesocosm study, the project has shown the utility of a large scale experimental approach for applying scientific rigour to environmental understanding of the interactions between offshore wind farms and the organisms that share the coastal environment.

The mesocosm site could be used for further studies and considering the logistics and expense of installing the facility it would be a good use of existing resources to reuse it.

The existing permissions and licences for the site of the mesocosms were due to end in February/March 2008. Following discussions within the project team, with Cefas and with Nature Bureau/COWRIE representatives it was seen as advantageous to seek extension to the permissions. The immediate benefit was that the mesocosms and associated structures would not need to be decommissioned as early as planned. Permitted extension would also provide the potential to reuse the mesocosm equipment for further relevant research using this unique set up. Extensions to the site permissions and licences have been obtained for:

- Section 34 consent
- FEPA licence
- Crown Estate

Details are included in the COWRIE 2.0 EMF Third Interim Report.

### *EMF Emitted by Sub-sea cables*

There are two approaches suggested. The first is to build on the EMF sensor technology that has been developed through COWRIE projects to provide suitable equipment and protocol for determining the intensity of EMF emitted and its variability in relation to power production. A greater understanding of the spatial variability and over time is required to interpret whether the emissions are likely to be constant stimuli to the EM sensitive species inhabiting the environment around the wind farms.

The second approach is to undertake controlled studies of different cable configurations and specifications to more fully understand the electromagnetic environment associated with offshore wind farm sub-sea cables.



## Section 2 – Technical Report

### 1. Executive Summary

The Environmental Technical Working Group (ETWG) of COWRIE commissioned the priority research project COWRIE 2.0 EMF with the objective to determine if electromagnetic sensitive fish respond to controlled electromagnetic fields (EMF) with the characteristics and magnitude of EMF associated with offshore wind farm (OWF) power cables.

The project was undertaken by a consortium with representatives from Cranfield University (Project Coordinators), Centre for Marine and Coastal Studies Ltd (CMACS), Centre for Fisheries, Environment and Aquaculture Science (CEFAS) and Centre for Intelligent Monitoring Systems (CIMS), University of Liverpool.

The project took an experimental research approach by enclosing a section of sub-sea cable within a suitable area of seabed using an approach known as 'mesocosm studies' to allow the response of elasmobranch test species to controlled electromagnetic fields (EMFs) to be assessed within a semi-natural setting. The study aimed to answer the primary research question:

- Do electromagnetically (EM) sensitive organisms respond to anthropogenic EMFs of the type and magnitude generated by offshore wind farms?

The final report for the study is presented here and is formed of two main sections. The first is a Management Report for the COWRIE Board that covers an overview of the project, the achievements and also the resources used. The second section is the main Technical Report which presents the details of the methodology, the data analysis and results and an assessment and interpretation of the findings. Finally, overall conclusions and recommendations are provided. Further supporting information is provided in a set of Appendices.

The study was conducted under controlled research conditions but to improve its applicability to the actual situation found at a wind farm the mesocosm experiment took place in a shallow, sheltered coastal water location. Two sections of high current, low voltage 3-phase electricity cable, which produced EMF similar in characteristics to an OWF cable, were buried to 0.5-1m depth in the sandy seabed, 10-15m from the surface. Two identical, almost circular mesocosms were constructed of polyethylene piping filled with concrete, with the sides and top covered with a 25mm nylon mesh and moored into place on top of the cables. The mesocosms were 40m in diameter and rose from the seabed 5m into the water column. To produce the required EMF a 125kV generator was attached to one of the cables and an electrical load and inverter regulated the current output at 100A with the terminal line voltage at approximately 7 volts AC. The EMF generated by the energised cables was monitored using custom built *in situ* pod dataloggers throughout the experimental study. Other environmental variables such as tidal current and temperature were recorded on site.

Ultrasonic telemetry technology (Vemco VRAP) was used to detect the real-time movements of individually identifiable elasmobranch fish within a mesocosm in relation to the energised sub-sea electricity cable. A second mesocosm without the cable energised was used as a reference.

Between August and December 2007, three repeats of the mesocosm study (Trials 1, 2 and 3) were conducted. To eliminate the possibility of site specific effects, the experimental (live) and control mesocosms were switched between Trials. In the live mesocosm, the fish were exposed to one EMF emission during the day and one during the night, each day over an experimental period of around 3 weeks. Three species of electrosensitive, elasmobranchs were studied, two species in any one experimental Trial. The benthic Thornback Ray (*Raja clavata*), the free-swimming Spurdog (*Squalus acanthias*) and benthic Small-spotted Catshark/Lesser-spotted Dogfish (*Scyliorhinus canicula*). We used two types of acoustic tag: coded and continuous. The coded tags allowed us to study the patterns of distribution of a number of fish whereas the continuous tags provided finer resolution data of a sub-set of the fish.

To provide confidence in the results obtained we took a conservative, hierarchical approach to the analysis using three different scales:

- Overall spatial comparison of fish densities within both mesocosms based on all the tag data through kernel probability density function analysis.
- A comparison of fish numbers present/absent in relation to distance from the cable. These data were further broken down into a comparison of fish numbers present within the zone of potential detection by the fish. Based on both coded and continuous tag data.
- A fine scale analysis of individual fish movement and distance from the cable based on the continuous tag data.

We applied a comprehensive test to the data to determine if there was any statistical basis for looking more closely at subsets of data which may have shown any apparent differences in the results. If the comprehensive test was significant then pair wise comparisons were applied using the same level of statistical significance (set at a probability of 5%). If the test was non-significant then no further tests were carried out.

Within the mesocosms the actual EMF produced extended around 2m either side of the cable axis. This was less than EMF modelling had predicted and can be attributed to small differences in the cable characteristics, problems with ensuring the generator was providing a predictable and constant EMF when switched on and the placement of the EMF dataloggers. Nevertheless both the magnetic and induced electric fields produced were within the range of detection of the elasmobranchs but at the lower end of the range.

We focussed our more specific analysis on the three hour period around a cable switch on event (1 hour before switch on, 1 hour that the cable was energised and the hour following the switch off). The distance of each fish away from the cable during these hour periods was compared based on the positions of the fish in 1m segment areas progressively moving away from the cable axis. Frequencies of fish in each segment were calculated and normalised for the area available in each segment, and by total number of position fixes within the mesocosm.

The overall analysis showed that there were significant differences between the numbers of individual fish within the EMF zone (ie. 2m either side of the cable). There were significantly greater numbers of Catshark within the EMF zone of the live mesocosm when the cable was switched on during the night for Trial 2 compared to the numbers present before and after the cable was energised. There was also a significantly greater number of Catshark present in the zone during the day for Trial 3 when the cable was switched on compared to afterwards. For all other comparisons there was no statistically significant difference. This result is important as it demonstrates that there was some behavioural response of being nearer to the cable for one of the species, *S. canicula*, some of the time and is based on both sets of tagged fish (coded and continuous). The response occurred during both the Trials that the Catsharks were studied. There was no statistical evidence that the other two species were nearer to the cable during switch on.

To further explain the differences found in the overall study we analysed the fine scale movement responses of the fish fitted with continuous data tags. Not all the continuous data were useable but sufficient events of the fish being tracked before, during and after the cable was turned on, both within the live and the control cages allowed us to analyse the fine scale movements of some of the fish.

The time between each position fix using the number of deployed continuous tags was on around 2 mins 26 secs. To analyse these data we again looked at the EMF zone either side of the cable axis for both the live and the control mesocosm. Within ArcGIS we calculated the distance of each position fix from the line of the cable, which we termed 'Near Distance' and determined the straight line distance between each successive position fix, which we termed 'Step Length'.

There were significant differences overall for the Rays Near Distance data both for the live and the control cage. But no overall differences in the Near Distance data for Catshark and Spurdog. There were significant differences for the Catshark and the Rays in the live mesocosm in terms of Step Length but no differences in the control mesocosm.

For some Rays there were significant differences in the distance away from the cable in the live and also the control mesocosms. This result demonstrates the importance of including a control to ensure that evidence of response is not misinterpreted.

In terms of the Step Length data two species, Rays and Catshark responded significantly and these were only in the live mesocosm. The Step Length (ie. the rate of movement) was significantly greater for three out of five Ray individuals when the cable was switched on. There were no differences in the control data set; therefore suggesting that the Rays moved more when the cable was on.

The Catshark moved significantly more after the cable was switched off. Two individuals out of four showed this increased movement however there appeared to be some consistency in response for all individual Catsharks, particularly in comparison to the control data.

Overall, the mesocosm study provided evidence that the benthic, elasmobranchs species studied can respond to the presence of EMF that is of the type and intensity associated with sub-sea cables. The response is not predictable and does not always occur; when it does it appears to be species dependent and individual specific, meaning that some species and their individuals are more likely to respond by moving more or less within the zone of EMF. The main result of Catshark being found nearer to the cable and moving less is consistent with the area restricted searching that is associated with feeding in benthic Catsharks. The responses of some Ray individuals suggests a greater searching effort during cable switch on.

To draw comparison between the EMF within the mesocosms at Ardtoe and the EMF emitted by wind farm cables we used the same pod dataloggers that were deployed within the mesocosm set up with additional measurements using hand held EMF probes. EMF measurements were obtained for two operational offshore wind farms, North Hoyle and Burbo Bank, both located in Liverpool Bay, UK during January and February 2008.

Measurements were made in the shallow water around the outgoing tide line over a period of 2-3 hours. Buried wind farm cables were located with a combination of GPS to within 1-5m, a magnetometer and real-time measurements of iE fields with a hand-held sensor. The hand-held sensor and magnetometer were first used to find the point of greatest field strength in water up to half a metre deep.

Current flows in each of the 36kV cables (i.e. wind farm generating statistics) at the time of survey were kindly provided by the wind farm operators (npower at North Hoyle and SeaScape Energy at Burbo). Variation in electrical current within the cable will have changed the B and iE Field readings taken on site, therefore the data were normalised to 100A in order to make comparisons with the results taken at Ardtoe.

At Burbo, the maximum magnetic field recorded was  $0.6\mu\text{T}$  and when normalised to 100A was  $0.23\mu\text{T}$ . Moving away from the cable the electric field decreased with the measured E field varying from approximately  $30\mu\text{V/m}$  close to the cable to around  $15\mu\text{V/m}$  approximately 150m away from the cable. This is a much slower rate of decay than anticipated (theoretically electric fields are expected to decay as  $1/\text{distance}^3$ ). The reason for the persistence of the electric field was not clear. The E field along the cable was different when compare with other cables, which is likely to be a result of different current applied to different cables.

At North Hoyle, the maximum normalised electric field measured was larger than at Burbo (maximum approximately  $110\mu\text{V/m}$ ). The electric field detected at North Hoyle appeared to be potentially confounded with other EMF sources which resulted in less comparability with the Ardtoe and Burbo data. The source of these E fields is not known, they may be due to return currents through the earth or other non identified sources of interference.

The cable set up, the depth of burial (to approximately 1m) and the magnetic and electric fields recorded at Ardtoe were comparable to the wind farms. The maximum B field was just under  $8\mu\text{T}$  which was associated with an iE field of approximately  $2.2\mu\text{V/m}$ . These EMF intensities were lower than we originally planned. This can be explained by the fact that there were small differences between the cable parameters used in the modelling and the characteristics of the

cable that was actually used in the study. Furthermore, the realities of variability in where divers located the pod dataloggers with respect to the cable position within the sea bed would lead to differences in the EMF measured. The differences were not large when we consider that we were dealing with very small E fields ( $\mu\text{V/m}$ ) and B fields ( $\mu\text{T}$ ).

Based on the responses of the fish in the Ardtoe experiment and the level of EM-emission at one of the wind farm sites we would predict that EM-sensitive species would encounter fields at or above the lower limit of their detection 295m from a cable. Hence there is potentially a large area that the species could respond within.

Considering its novelty, the enormity of the logistics and its uniqueness the project met its objective by demonstrating that some electrosensitive elasmobranchs will respond to the EMF emitted in terms of both the overall spatial distribution of one of the species tested and at the finer scale level of individual fish of different species. The field survey provided evidence that the EMF previously predicted to be emitted by OWF cables do exist.

There remains a real requirement to objectively determine if the responses we observed will have either positive or negative effects on elasmobranchs of the EMF encountered. This was not an objective of the study and it can only be determined realistically through a combination of monitoring at offshore wind farm sites with appropriate analysis over time and further experimental based studies of specific behavioural responses that could indicate potential impacts.

## 2. Non-technical Summary

The overall objective of the project reported here was to determine if electromagnetic sensitive fish respond to controlled electromagnetic fields (EMF) with the characteristics and magnitude of EMF associated with offshore wind farm (OWF) power cables.

Taking an experimental research approach within a semi-natural setting, a section of sub-sea cable was enclosed within a large fish cage (known as a 'mesocosm') on an area of seabed with similar site characteristics to an OWF. Two identical mesocosms were used and the response of test fish species (sharks, skates and rays) to controlled electromagnetic fields was assessed through recording their movements in real time using an acoustic tracking system that remotely collected information on the position of the fish at times when the cable was energised and therefore emitting EMF and times when the power was switched off.

In a subsequent field study we directly measured the EMF emissions at two offshore wind farm sites to

Taking all the results together the project has determined the following:

- There is evidence that the benthic elasmobranchs species studied did respond to the presence of EMF emitted by a sub-sea cable.
- This response, however, was variable within a species and also during times of cable switch on and off, day and night.
- Analysis of the distribution and density of the fish within the mesocosms showed that all the fish species moved throughout the mesocosms regardless of whether there was any EMF present or not. There was a predominance of movement towards the offshore side of the mesocosms.
- Analysis of the overall spatial distribution of fish within the mesocosm was non-random and one species, *Scyliorhinus. canicula* (the Small-spotted Catshark) was more likely to be found within the zone of EMF emission during times when the cable was switched on.
- The fine scale analysis system used was limited by the technology available which meant the number of fish individuals studied was low. However, there were differences found for some individuals of Thornback Rays (*Raja clavata*) and Catshark in terms of their rate of movement around the zone of EMF emission when the cable was switched on.
- There appeared to be a response by the Rays of being nearer to the cable when it was turned on; however a similar response was found in the control mesocosm. This highlights the importance of including the control in the study. But their Step Length (ie. the distance covered between two successive positions) was higher once the cable was switched on.
- Overall the results suggest that the Catsharks will at times be found more of the time near to the energised cable and they will be moving less than during times when the cable is not switched on.
- There was no depth related movement during the time that the cable was on or off.
- There did not appear to be any differences in the fish response by day or night or over time.
- Whilst the results clearly showed individual differences to the EMF there were insufficient occurrences of individuals responding consistently over time for any determination of habituation. Further study on more individuals would be required.

To draw comparison between the EMF within the mesocosms at Ardtoe and the EMF emitted by wind farm cables we used the same EMF dataloggers that were deployed within the mesocosm set up with additional measurements using hand held EMF probes. EMF measurements were obtained in the intertidal zone close to the land fall area of the export cables from two operational offshore wind farms, North Hoyle and Burbo Bank, both located in Liverpool Bay, UK during January and February 2008.

Both sets of OWF cables emitted EMF. The Burbo Bank emissions were oriented as predicted but were more persistent than expected, however the emitted fields were comparable with the

smaller emissions we recorded at the experimental mesocosm site. The cable emissions for North Hoyle appeared to be confounded by some other unexplainable source of EMF.

Based on the responses of the fish in the Ardtoe experiment and the level of EM-emission at one of the wind farm sites we would predict that EM-sensitive species would encounter fields at or above the lower limit of their detection 295m from a cable. Hence there is potentially a large area that the species could respond within.

Considering its novelty, the enormity of the logistics and its uniqueness the project met its objective by demonstrating that some electrosensitive elasmobranchs will respond to the EMF emitted in terms of both the overall spatial distribution of one of the species tested and at the finer scale level of individual fish of different species. The field survey provided evidence that the EMF previously predicted to be emitted by OWF cables do exist.

There remains a real requirement to objectively determine if the responses we observed will have either positive or negative effects on elasmobranchs of the EMF encountered. This was not an objective of the study and it can only be determined realistically through a combination of monitoring at offshore wind farm sites with appropriate analysis over time and further experimental based studies of specific behavioural responses that could indicate potential impacts.

### 3. Background

Worldwide there is an ever increasing interest in marine renewable energy developments and their potential environment impacts. Assessing the impact, both beneficial and detrimental, on the environment requires the appropriate evidence. In the UK and northern Europe the focus over recent years has been on Offshore Wind Farms (OWF) and the environmental impact of constructing and operating large scale wind farms.

One recurring topic of interest is whether there are any environmental impacts related to the electricity generated by these wind farms. The evidence base is relatively poor (Gill 2005) however, there are some studies that have indicated that there are a number of marine organisms that may be able to respond to both naturally occurring and anthropogenic electromagnetic fields (EMF) in the coastal environment (Polea et al 2001; Gill et al 2005; Ohman et al 2007). More specifically studies, such as COWRIE 1.0 ([http://www.offshorewindfarms.co.uk/Assets/1351\\_emf\\_research\\_report\\_04\\_05\\_06.pdf](http://www.offshorewindfarms.co.uk/Assets/1351_emf_research_report_04_05_06.pdf)) and have used modelling techniques to predict that the sub-sea cables used by the offshore wind industry emit EMFs of the type and intensity that may be within the range of detection by such organisms. However, to date, there have not been any studies that have specifically aimed to quantify whether there is any response by electromagnetically (EM) sensitive organisms to the EMFs emitted by the sub-sea cable. Furthermore, there has been no direct evidence that the subsea cables used by offshore wind farms actually emit the fields predicted.

### 4. Project Objective

*To determine the response of electromagnetic sensitive organisms to controlled electromagnetic fields (EMF) with the characteristics and magnitude of EMF associated with offshore wind farm power cables.*

The Environmental Technical Working Group (ETWG) of COWRIE commissioned the priority research project COWRIE 2.0 EMF with the objective to determine if electromagnetically sensitive fish respond to controlled electromagnetic fields (EMF) with the characteristics and magnitude of EMF associated with offshore wind farm power cables.

The project was undertaken by a consortium with representatives from Cranfield University (Project Coordinators), Centre for Marine and Coastal Studies Ltd (CMACS), Centre for Fisheries, Environment and Aquaculture Science (CEFAS) and Centre for Intelligent Monitoring Systems (CIMS), University of Liverpool.

The project took an experimental research approach by enclosing a section of sub-sea cable within a suitable area of seabed using an approach known as 'mesocosm studies' to allow the response of elasmobranch test species to controlled electromagnetic fields to be assessed within a semi-natural setting. Prior to the study and following peer-review of the project design it had been agreed with members of COWRIE that the mesocosm approach would be the best option for obtaining scientifically rigorous information required to answer the primary research question:

- Do electromagnetically (EM) sensitive organisms respond to anthropogenic EMFs of the type and magnitude generated by offshore wind farms?

The study was conducted under controlled research conditions but to improve its applicability to the actual situation found at a wind farm the mesocosm experiment took place in a shallow, sheltered coastal water location. The study used ultrasonic telemetry technology, to detect the real-time movements of individually identifiable fish within a mesocosm in relation to an energised section of sub-sea electricity cable. A second mesocosm without the cable energised was used as a reference.

## 5. Project Methodology

### 5.1. Study Location

Following a preliminary assessment of suitable sites, Loch Ceann Traigh, near Ardtoe, west of Scotland (OS Grid reference: NM 598 709) was chosen for the study (Figure 1).



**Figure 1.** Location map of mesocosm study showing the two mesocosms (red circles) and the VRAP acoustic tracking triangle and the Ardtoe marine laboratory facilities (Blue).  
© Crown Copyright.

The relative homogeneity of the sea bed and the low incline of the Loch Ceann Traigh site and the absence of any background EMF provided an ideal location for the mesocosm study. The site was approximately 100m from the shore, which was convenient for locating the power generator set up required for the experimental study.

Furthermore, the location was adjacent to the Viking Fish Farms Ltd, Ardtoe aquaculture and marine laboratory facility from where the project was coordinated. Ardtoe is directly across the loch from the study site (approx. 2.5 km; Figure 1) and there are large expanses of flat sandy shore at low tide which provided sufficient beach area to construct the mesocosms prior to deployment. There was also good access from the road to the beach.

In order to undertake the study in the waters of the west coast of Scotland near Ardtoe, a number of consents and permissions were obtained:

- Food and Environment Protection Act 1985 (Part II Deposits in the Sea).
- Coast Protection Act 1949 Section 34 Consent.
- The Crown Estate
- Highland Council Planning Permission
- Scottish Environment Protection Agency
- Scottish Natural Heritage



- Home Office licensing
- Local land owner access to jetties and field site

Details of the licensing and permission requirements were reported in the COWRIE 2.0 EMF Phase 2 Stage 1 Project Plan Update report (available on request from COWRIE).

## 5.2. Experimental Mesocosms

The experimental mesocosms were designed and built by Fusion Marine Ltd and installed by a commercial dive team, North West Marine Ltd. Two identical sections of electricity cable were sunk in 10-15m of water and buried to 0.5-1m depth. The mesocosms were constructed of polyethylene piping filled with concrete, with the sides and top covered with a 25mm nylon mesh and moored into place on the sandy seabed on top of the cables (see plan view Figure 2). The two mesocosms were identical. They were 40m in diameter and rose from the seabed 5m into the water column. Zipped entry points on the top and the side of the netting allowed fish to be entered and removed and for diver access into the mesocosms. Further details, if required, can be found in COWRIE 2.0 EMF Second Progress Report (available on request from COWRIE).

Owing to the length (approx. 300m) and weight of electric cable used and the time constraints on the project, the cables were deployed from a workboat and crane using surface floats as position markers. Once on the seabed, the electrical cables were buried to a depth of approximately 0.5 – 1m. Unfortunately, one of the cables was laid off centre during installation and could not be moved once the mesocosms had been put in place over the cables. The different positions of the cables within the mesocosms were taken into account in the analysis of the fish movement data.

The on-site mesocosm construction and deployment took around four weeks and was completed in June 2007. A number of factors, particularly related to professional diving health and safety, meant that the construction time and therefore the cost was greater than initially budgeted. Details are summarised in the management report section and highlighted in the COWRIE 2.0 EMF 2<sup>nd</sup> Quarterly Interim Report (available on request from COWRIE).

## 5.3. Electromagnetic Field (EMF) Production

To generate the EMF most similar to the standard offshore wind farm cables, a high current, low voltage 3-phase SWA (Steel Wired Armoured) cross linked XLPE cable was used within the mesocosms. Tables 2a and 2b highlight the properties and the parameters of the mesocosm cables. The cable had a conductor cross section of 16 mm<sup>2</sup> and could carry 600-1000 V and was rated from 25 to 730A. The cable was supplied from commercial stock and was suitable for direct burial.

**Table 2a** . Electromagnetic properties of the materials of the mesocosm cable.

	Relative Permittivity $\epsilon_r$	Conductivity $\sigma$ (s/m)	Relative Permeability $\mu_r$
Conductor (Copper)	1.0	58, 000, 000	1.0
XLPE/PVC	2.5	0.0	1.0
Sheath (PVC)	2.5	0	1.0
Armour (Steel wire)	1.0	1,100, 000	300
Seawater	81	5.0	1.0
Sea bed	25	1.0	1.0

**Table 2b.** Major parameters of the mesocosm cable.

	<b>Thickness (mm)</b>	<b>Diameter (mm)</b>	<b>Note</b>
Conductor (Copper)		4.6	
Insulator (XLPE)	2	10.5	Outer diameter
Sheath (PVC)	2.3	11.5	Outer diameter
Armour (Steel wire)	2.0	25	Outer diameter
Max Voltage (kV)			135 kV
Max Current (A)			700 A

The main differences between the reference (wind farm) and mesocosm cable were:

- a) The sheath of the mesocosm cable was PVC, not lead, which meant more leakage of the magnetic field (B field) to the outside of the cable with the same current. It also meant that less current was required to generate the same B field, hence the induced electric field (iE Field) in the water.
- b) The dimensions of the cable were much smaller. The thickness of the steel armour was reduced, which again meant less current was required to generate the same B field (hence the induced E field) in the water.

From EMF equivalence modelling simulations that we conducted earlier in the project it was concluded that:

- The suggested mesocosm SWA cable could generate EMF similar to that emitted by an offshore wind farm cable.
- To produce the required B field around the cable, which would then induce an E field, a current around 170A needed to be applied.

Details can be found in the report: COWRIE 2.0 Electromagnetic Fields (EMF) Phase 2 Stage 1 Project Plan Update (available on request from COWRIE).

To produce the required EMF a 125kV generator was rented from Aggreko UK Ltd. The end of the cable was terminated with a low impedance, three phase star configured termination. An electrical load and an inverter, with a separate power source, were placed in line which regulated the current output at 100A with the terminal line voltage at approximately 7 volts AC. This design, however, suffered some initial problems and delayed the start of the experimental Trial 1 for several weeks. During August 2007 an inverter module was built and installed by Aggreko UK Ltd, which successfully maintained the generator output at 100A for the remaining experimental trials.

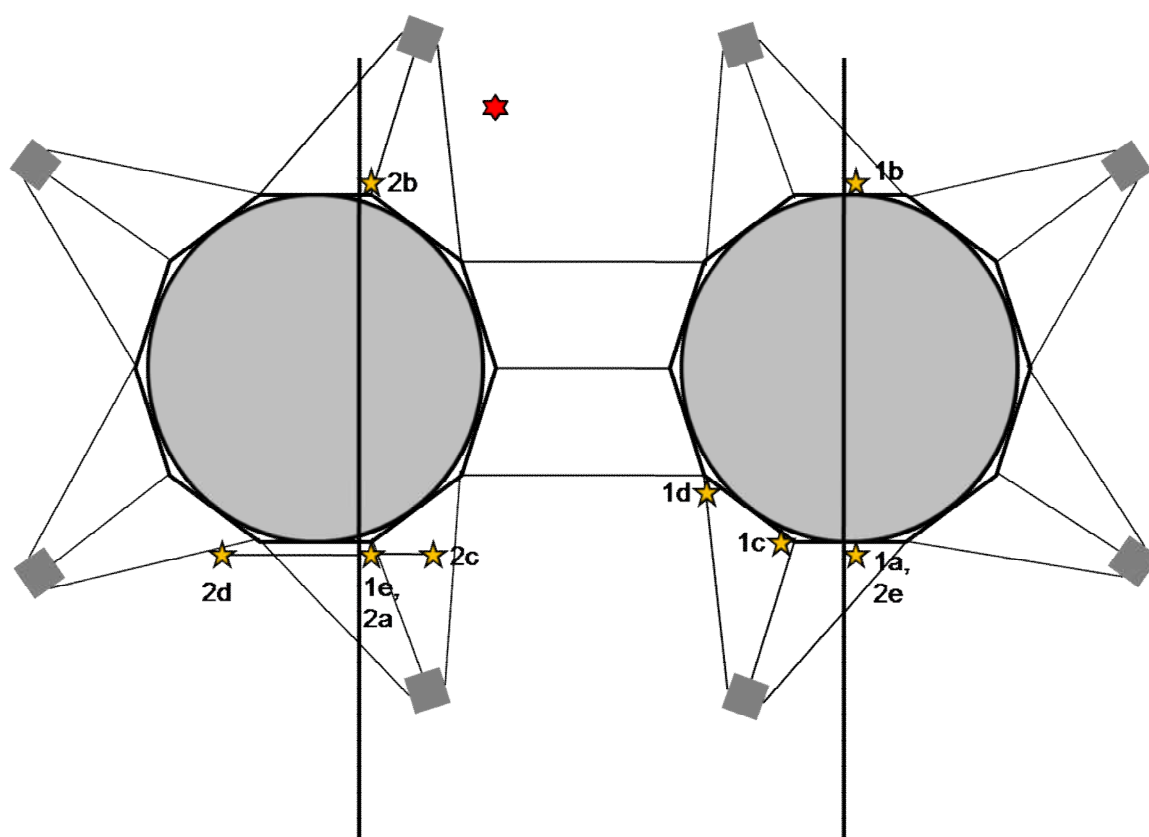
### **5.3.1. Electromagnetic Field (EMF) Measurement**

The EMF generated by the energised cables was monitored using *in situ* pod dataloggers designed and built by CIMS, Liverpool University. The pods were made from nylon cylinders 80cm in length and diameter of 30cm. Inside the pods the EMF electronic circuitry was sealed and two sensors were positioned at either end of the pod. In total five pod dataloggers were deployed at the end of August 2008 and placed in the positions shown in Figure 2 to record the EMF emission and its characteristics in terms of orientation and distance away from the cable:

- 1a and 2a - adjacent to the live cable as it entered the mesocosm;
- 1b and 2b - adjacent to the live cable as it exited the mesocosm;
- 1c and 2c - 7.5m from the live cable;
- 1d and 2d - 15m from the live cable;
- 1e and 2e - adjacent to the non-energised cable.

Some dataloggers were positioned parallel to the axis of the cable while others were perpendicular. The objective here was to quantify any differences in the EMF according to geometry of the field as the EMF is greater along the length of the cable (axial EMF) compared to the EMF perpendicular to the length of the cable (normal EMF). The dataloggers were recovered

at the end of each experimental trial and their data downloaded. They were then reprogrammed and redeployed into the mesocosms in the positions shown in Figure 2.



**Figure 2.** Plan view of the experimental mesocosms showing the approximate locations of the cables (solid black lines) and the mooring system (grey lines). The mesocosms were approximately 40m across at their widest point. Red star indicates the deployment location of the current meter. Yellow stars indicate the deployment locations of the EMF pod dataloggers where number indicates trial number and letter indicates position in relation to the live cable: **a**= parallel to live cable as it enters the mesocosm; **b**= perpendicular to live cable as it enters the mesocosm; **c**= perpendicular to live cable at a distance of 7.5m; **d**= parallel to live cable at a distance of 15m; **e**= parallel to control cable as it enters the mesocosm. Note, for Trial 3 positions were the same as for Trial 1.

## 5.4. Environmental variables

Tidal information for the local area was downloaded from the UK Hydrographic Office website each week (EasyTide prediction for Loch Moidart, Scotland: <http://easytide.ukho.gov.uk> ).

A current meter (FSI 2d ACM) was hired from Cefas and deployed on site approximately halfway along the seaward edge of the mesocosm site (see Figure 2) at the beginning of August. This current meter was set to record local currents at the site until the end of October. Unfortunately, the current meter was lost during the study therefore we have no direct records of current on site for much of the study. A second meter was, however, deployed during November and recovered in December. The mean current recorded during this time was 4.25 cm/s +/- 2.03 (S.D.) with a range of 0.12 to 13.80 cm/s. A graph of the current and temperature data during this period is shown in Appendix 3.

## 5.5. Experimental Design

Between August and December 2007, three repeats of the mesocosm study (Trials 1, 2 and 3) were conducted (Table 3). To eliminate the possibility of site specific effects, the experimental and control mesocosms were switched between trials. During the project we had aimed to conduct four trials, however, due to the very tight time constraints of the project, adverse weather and other logistical issues we were unable to complete all four trials.

**Table 3.** The basic experimental set up. For positions of mesocosms see Figure 3.

<b>Trial Number</b>	<b>Mesocosm 1</b>	<b>Mesocosm 2</b>
1	Live	Control
2	Control	Live
3	Live	Control

For each trial, the individual fish of each species within the mesocosm with the energised cable (known as the 'live' mesocosm) encountered the same EMF over a period of approximately three weeks. The other mesocosm held the same species and a similar number of fish but did not have any EMF associated with the cable. The movement of all fish was recorded by the VRAP system (see section 5.7).

In the live mesocosm, the fish were exposed to one EMF emission during the day and one during the night, each day over the experimental period. The objective was to provide data that would allow us to understand individual variability in any response and, if a response did occur a sufficient number of times, to try and determine if the fish could habituate to the emissions encountered.

The timing of the generator switch on was randomly assigned within each day and night period. Day and night were determined as the time between sunrise and sunset (day) and the time between sunset and sunrise (night), with times of sunrise and sunset being from the Nautical Almanac (HMSO) for the appropriate latitude (56°N) and date.

## 5.6. Study Species

We used two species of electrosensitive, elasmobranchs in each trial: the benthic Thornback Ray (*Raja clavata*; Total Length (TL) = 50.7 to 85.7 cm) and the free-swimming Spurdog (*Squalus acanthias*; TL = 60.5 to 119.0 cm) were the focus in Trial 1. However, the Spurdogs natural tendency to continuously swim meant that their tracks were subject to greater variation than the less mobile Rays. We judged from pilot analysis of the Spurdog data that their continual swimming reduced the possibility of detecting any movement differences in relation to the position of the electricity cable. Following consultation and agreement with COWRIE we replaced the Spurdog with the benthic Small-spotted Catshark/Lesser-spotted Dogfish (*Scyliorhinus canicula*; TL = 58.6 to 69.8cm) for the remaining two experimental trials.

Acoustic transmitters (see section 5.7) were externally attached using Peterson discs (n=2) or surgically implanted into the peritoneum of the fish under general anaesthetic (2-phenoxyethanol, 0.4ml/l). All data storage tags used (see section 5.8) were surgically implanted into the peritoneum. Following surgery, fish were released into large (10m diameter) aquarium tanks to recover for periods of around three days. Tagged fish were transported to the study site in tanks of aerated seawater and then transferred into the mesocosms by divers using a purpose built 1m x 1m x 2m submersible transport cage.

Table 4 shows a summary of the fish species and their numbers in the mesocosms during the study trials. The fish were distributed evenly between the live and control mesocosms. Where there was an odd number of fish the extra fish was put into the live mesocosm. The number of

fish and tags recovered is also highlighted. We had some mortalities in both mesocosms, particularly in the first trial, which we believe to be a result of competition for food by a large number of opportunistic scavenging brown crabs (*Cancer pagurus*) that dug their way into the mesocosms. The protracted period of time before the study properly began would have exacerbated this problem as we had no way of knowing whether the fish obtained sufficient food when we fed them every four days. If fish died we were not able to recover their acoustic or data storage tags unless the divers found them on the bottom of the mesocosm. The consequence was that some of the tracking data was not usable and also we had fewer tags for the subsequent Trials (2 and 3). The decrease in tags available is reflected in the decreased number of fish used in each Trial, as shown in Table 4.

At the end of each trial, fish were recovered from the mesocosms by hand by commercial divers and acoustic transmitters and data storage tags recovered for downloading and reuse.

**Table 4.** The species and number of fish introduced into the mesocosms (Fish in) for each study trial. The number of fish and tags retrieved (Fish + tags out) is also shown.

Species	Trial					
	1		2		3	
	Fish In	Fish + tags Out	Fish In	Fish + tags Out	Fish In	Fish + tags Out
<i>Raja clavata</i>	16	9	9	6	9	7
<i>Squalus acanthias</i>	16	12	3**	3	n/a	n/a
<i>Scyliorhinus canicula</i>	n/a	n/a	12	7	10*	8
Total Number	32	21	24	16	19	15

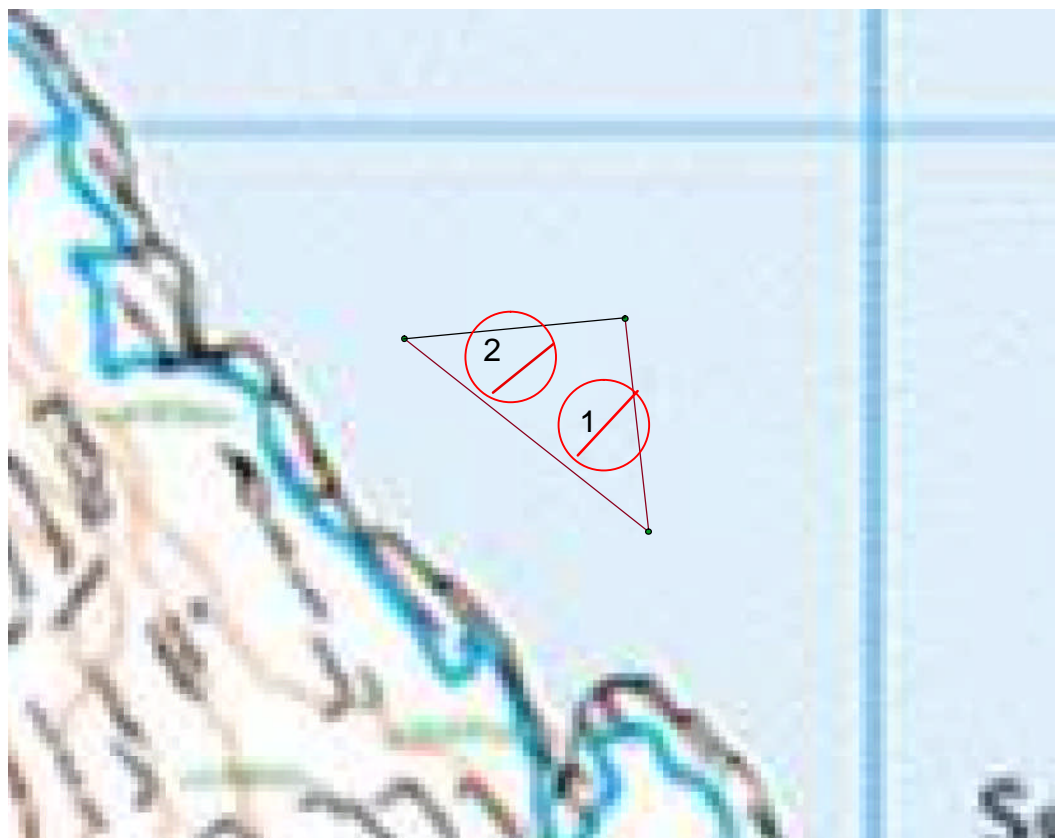
\*\* - all of these fish not caught from the previous Trial.

\* - one fish remained from previous Trial.

At the end of each trial, fish were recovered from the mesocosms by hand by commercial divers and tags and transmitters recovered for downloading (DTSSs) and reuse.

## 5.7. VRAP Acoustic Tracking

The movements and space use of fish within the mesocosm were determined by equipping each individual with an acoustic transmitter (Vemco Ltd.). Fish positions were tracked using a Vemco Radio Acoustic Positioning (VRAP) system. The VRAP system consisted of three listening stations (buoys) placed in a triangle, 100-150 m apart, around the two mesocosms (see Figure 3).



**Figure 3.** Approximate location of mesocosms (red circles) within the VRAP buoy triangle. Mesocosm number is indicated.

Attached to each buoy was a hydrophone that detected the acoustic pulses from the tags that the fish were carrying. At first the hydrophones were located next to the buoys at the sea surface but during the first stages of Trial 1 it became apparent that in bad weather the wind and wave movement caused a decrease in the accuracy of the position fixes of the tags. We therefore repositioned the hydrophones as close as possible to the VRAP buoy's static anchor (approximately 1 m from the seabed) to remove them from the surface water disturbance and hence to ensure more accurate and consistent position fixes of the fish.

The buoys transmitted data (transmitter codes and times of detection) by radio link to the base station at the Ardtoe Laboratory. In order for a triangulated position to be calculated, all three buoys had to register a signal from a transmitter carried by a fish. The location of each fish's transmitter was determined from the arrival time of the acoustic signal at each buoy and the speed of sound in seawater.

In order to obtain sufficient statistical significance to be able to determine whether or not fish behaviour was influenced by the electromagnetic fields, we needed to track a large number of fish per trial. Prior to commencing the experiment, we calculated that in order to achieve a statistical power of 75%, the movements of 16 fish would need to be tracked in relation to the EMF per trial.

Two types of acoustic transmitter were available: continuous and coded transmitters. The acoustic pulse frequency and periodicity of these transmitter types varies. Continuous transmitters produce an acoustic pulse at a set periodicity (for example, 1 sec). Due to the potential for clashes (i.e. co-occurring pulses), continuous transmitters operate at unique acoustic frequencies (kHz). However, only a limited number of unique frequencies (eight frequencies within the range 51-84 kHz) are available on the VRAP system. In contrast, coded tags all operate at the same frequency (69 kHz), but each coded tag has a unique acoustic pulse signal that allows the VRAP system to differentiate between the tags (i.e. tag number is encoded in the acoustic pulse). As coded transmitters all operate at the same acoustic frequency, clashes are prevented by randomisation of pulse intervals.

Owing to the regularity of acoustic pulse transmission, continuous transmitters can provide fine-scale tracks of fish movements. Therefore, to monitor the fine-scale movements of eight fish, four per mesocosm covering two species, we used the maximum number of eight continuous acoustic transmitters (V16-4L), which emitted an un-coded acoustic pulse using one of the eight unique frequencies (51, 54, 57, 60, 63, 75, 78, 81 kHz) at one second intervals. In order to obtain sufficient statistical power, the number of animals tracked had to be increased, so we also used coded transmitters (V13-1H-R64K). These transmitters transmitted at a random interval between 60 and 180 seconds (n=27) or 150 and 300 seconds (n=3). The maximum number of fish tracked at any one time with coded transmitters was 24 (12 fish per mesocosm, six of each species per Trial).

During the experiment the VRAP system recorded data for the whole of a Trial, cycling every 30 minutes between recording the transmissions from the continuous transmitters (providing high temporal resolution tracks of a limited number of individuals) and the coded transmitters (providing lower temporal resolution tracks of a greater number of individuals). Whilst continuous transmitters were tracked, positioning was performed in sequence with each transmitter's frequency being monitored for a 12 second period. At this listening regime, the position estimates were obtained for each of the eight fish approximately every two minutes (which also allowed time for radio uplink between frequency changes). In the 30 minute periods when the VRAP system was monitoring the coded transmitter radio uplinks from the acoustic buoys to the VRAP base station occurred every 60 seconds. Using calculations provided by the manufacturer (Vemco), the lowest average inter-position interval which could be achieved using these tags was seven minutes.

All valid transmitter detections were recorded. VRAP tracking was restarted on a daily basis allowing regular file back up and archiving.

## **5.8. Data storage tags**

Some of the fish were also equipped with small (8 mm x 35 mm) archival tags (Cefas G5, Cefas Technology Ltd.) that recorded pressure (i.e. depth) every 20 seconds and temperature every 5 minutes. Unlike the VRAP system that provided real-time estimates of fish position, data storage tags had to be recovered and downloaded to obtain temperature and depth data.

## **5.9. VRAP Data Processing**

Following data acquisition, the tracking data for each experimental Trial were exported from the VRAP software and imported into MS Excel. Time stamped transmitter position estimates (in latitude and longitude) were then coded to indicate fish species and sex, time of day (day or night) and the mesocosm in which they were held (live or control). Times when the cable was energised were also coded, with each energising event being given a unique event number.

Three Spurdogs were not recovered between Trials 1 and 2 and one Catshark between Trials 2 and 3. Two of the Spurdogs and the Catshark continued to be tracked in subsequent trials. In such cases the trial number for which the fish were originally tagged was also noted. All transmitter positions from all three trials were then plotted in ArcGIS. Movement of the third Spurdog was not detected as it lost its tag. The data for lost tags was filtered out during data processing.

The project generated a very large amount of data which was collated, formatted and organised on site before being exported in the appropriate format for analysis within ArcGIS software at Cefas and Cranfield University.

The VRAP data were uploaded and analysed within ArcGIS. We then sub-divided the datasets by fish individual, Trial (1, 2 or 3), day/night and also by event, where an event was a known time when the generator was operating and the cable emitting an EMF in the live mesocosm. The data were then analysed for each event to look at specific movement variables that represented fish activity within the mesocosms.

Data recorded at the beginning of Trial 1, when the hydrophones were near the sea surface during the poor weather, were removed from the tracking dataset to improve the accuracy of the analysis. Following the removal of the early Trial 1 data, the distinct shapes of the cages could be identified in the ArcGIS dataset. To determine the exact location of the cages and cables, dGPS positions of cage nodes and cable positions were plotted in ArcGIS as well as a high temporal resolution tracking of a transmitter carried by a diver as they swam around the perimeter of the cages. From these two datasets, the positions of the mesocosms and power cables could be identified on the GIS map (Figure 3).

A number of recorded transmitter locations were determined as being outside either of the cages. These erroneous locations were primarily attributable to the errors associated with the accuracy of acoustic tracking method. However, the positioning error for our VRAP set up has been estimated by the manufacturer as less than 1m within the VRAP triangle, and was as good as the system can currently provide. In the small sections of each cage that lay outside the triangle there was a slight increase in the error but this was estimated to be around 1m. As fish were constrained within each mesocosm, transmitter locations determined as being outside the perimeter of either cage were assumed erroneous and removed from the dataset. In addition, any data relating to fish that had died during trials or lost tags were also removed.



## 6. Project Data Analysis and Results

An inherent property of animal movement data is that successive records are not independent. For example, the position that an animal moves to will depend on the position that it has moved from and this dependency is greater the shorter the time between position recordings. Such dependence between data is known as autocorrelation (Griffith 1992) and a number of studies have made suggestions of how to reduce the dependency of the data to allow normal statistical analysis to be undertaken (Schoener 1981; Swihart & Slade 1985). However, the suggested methods reduce the sample size and can also seriously alter the biological significance of the data. Animals typically move non-randomly hence any analysis should aim to take this into account (de Solla et al 1999).

In terms of the COWRIE 2.0 EMF study reported here, the effect of the previous position on the next position of a fish was regarded as of fundamental importance to the activity data obtained as we were interested in the effect of a fixed environmental stimulus, the electrical cable. Therefore, we did not correct for autocorrelation but standardised the inter position time interval to increase the accuracy and precision of the position fixes (de Solla et al 1999). We were aided by the VRAP tracking system which was set up to locate the fish positions at regular, short time intervals. We also standardised the time interval between fixes by dividing the distance covered (labelled 'Step Length') by the time taken to move from one position to the next.

We took a hierarchical approach to the analysis of the data using three different scales:

- Overall spatial comparison of fish densities within both mesocosms using kernel probability density function (KPDF) analysis based on all the coded and continuous tag data.
- A comparison of fish numbers present/absent in relation to distance from the cable. These data were further broken down into a comparison of fish numbers present within the zone of potential detection by the fish. Based on both coded and continuous tag data.
- A fine scale analysis of individual fish movement and distance from the cable based on the continuous tag data.

### 6.1. Notes on statistical procedures

In general, we took a conservative approach to the analysis, hence any significant results were less likely to be spurious or an artefact of the statistical procedures used thereby providing greater confidence in the results obtained.

Using multiple statistical tests can lead to an increased likelihood of incorrectly deciding that one or more of several comparisons are significant when in fact they are not. To guard against this we applied a comprehensive test to the data to determine if there was any statistical basis for looking more closely at subsets of data, which may then show any apparent differences in the results (Bart et al 1998). If a comprehensive test is significant then pair-wise tests can be applied using the same level of statistical significance, which in our case was set at a probability of 5%. If the test was non-significant then no further tests were carried out.

Parametric tests were applied when data met the assumptions of normality and homogeneity of variances. Otherwise we applied non-parametric statistical tests.

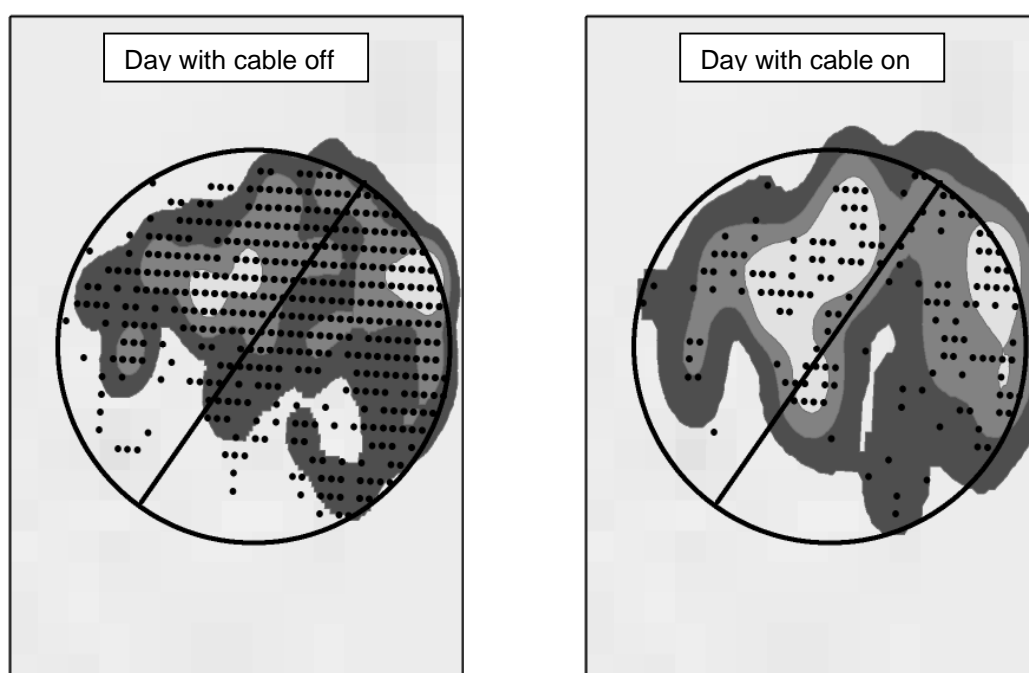
### 6.2. VRAP data analysis

#### 6.2.1. Kernel Probability Density Function Surfaces

Recorded transmitter positions were plotted using ArcView 9.0 (Environmental Systems Research Institute, USA). The Animal Movement Analysis Extension to Arcview (AMAE: Hooge and Eichenlaub, 2000) was used to estimate the extent of spatial distribution for each species in

each mesocosm by generating kernel probability density function (KPDF) surfaces for 95%, 75% and 50% volume estimates under the three-dimensional KPDF surface (see Worton, 1987, Seaman and Powell, 1996; Hooge *et al.*, 2000). The KPDF method is typically used in studies of territoriality and home range (Jones, 2005; Righton & Mills, 2006), and was therefore an appropriate analytical tool for this study.

The KPDF surface plots provided a qualitative illustration of the distribution of fish in each mesocosm (an example is shown in Figure 4). The shading in Figure 4 shows that fish were present throughout most of the mesocosm but there were some areas where fish density was higher shown by the white shading. The probability density surfaces shown are for 95% (dark grey), 75% (mid grey) and 50% (white). We visually assessed these plots for any differences in the distribution of each fish species associated with the cable when energised versus times when it was switched off. We also undertook a closer inspection of the data by limiting the KPDF plots to the hour before cable turn on, the hour during and the hour after the cable was turned off. The data were plotted for both the live and the control mesocosms. There were no conclusive results concerning fish density in relation to the cable from this analysis. The full set of KPDF plots are in Appendix 1.



**Figure 4.** Overview of the spatial distribution of rays (*R. clavata*) in ‘Live’ Mesocosm during the day time within Trial 3 using the KPDF analysis.

KPDF analysis does not easily lend itself to statistical investigation, therefore to further analyse the data we estimated the distance and distribution of fish locations within each mesocosm in relation to the axis of cable.

#### 6.2.2. Distance from cable analysis

The original COWRIE 2.0 EMF project proposal highlighted that the probable zone of EMF present within the range potentially detectable by the fish would extend 17m either side of the cable based on EMF modelling. Unfortunately, the actual EMF produced only extended around 2m either side of the cable. Details concerning this are provided in Section 8.

For each mesocosm, the distance (m) of each detected transmitter location (ie. fish) from the cable was calculated using the routine linear geometric methods based on the known x-y location of the ends of the cable and the x-y position of the transmitter. The shortest distance from the transmitter location to the cable was solved by using the formula:

$$ax+by+c = 0, \text{ where } y = ax+c \text{ describes the orientation of the cable to the x-y axis.}$$

For a point (m,n) the shortest distance (d) to the line is given by the formula:

$$d = (am + bn + c) / \sqrt{a^2 + b^2}$$

Transmitter locations were then assigned to area segments of the mesocosm at one metre intervals from the cable axis. Segment areas were calculated using routine circular geometrical methods (see: [www.1728.com/circ.part.htm](http://www.1728.com/circ.part.htm)) assuming the mesocosm to be a circle and the cable to be a chord of the circle. The distance from the cable to the perimeter of the mesocosm (the segment height or *sagitta*) was first calculated from the cable (chord) length and the radius of the mesocosm. The area of the mesocosm floor between the cable and the perimeter of the mesocosm (the segment area) was then estimated from the segment height and the mesocosm radius.

Segment areas were worked out successively, in 1m steps away from the cable, towards the perimeter of the mesocosm. The area of each 1m step was then calculated as the difference between two successive segment areas. Finally, the areas of the pairs of segments at equal distances on either side of the cable combined to give the total area of the mesocosm floor within a given 1m step from the cable.

Frequencies of fish in each segment were calculated and normalised for the area available in each segment, and by total number of position fixes within the mesocosm. Results of this analysis were plotted as bar charts for each species by trial and experimental or control mesocosm (Figures 5 to 10).

Finally, the number of individual fish (not transmitter locations) in the area 2 m either side of the cable one hour before, during (one hour), and one hour after, the cable was energised were compared. These numbers within the 2m area were first standardised to relative proportions according to the number of fish present in the mesocosm and detected by the VRAP system. An overall ANOVA was conducted and then if statistical significance was shown, paired t-tests were applied to determine where differences in standardised fish numbers occurred when the cable was energised and not both during the day and night (Figures 5 to 10).

The overall analysis showed that there were significant differences between the numbers of individual fish within the 2m area based on the standardised frequency of occurrence within and outside the area as depicted in Figures 5 to 10.

The ANOVA repeated measures analysis of data one hour before, during and after cable switch on was:

Rays Trials 1, 2 and 3;  $F = 113.007$ ,  $p = 0.04$

Catshark Trials 2 and 3;  $F = 115.169$ ,  $p < 0.001$

Spurdog Trial 1;  $F = 256.492$ ,  $p < 0.001$

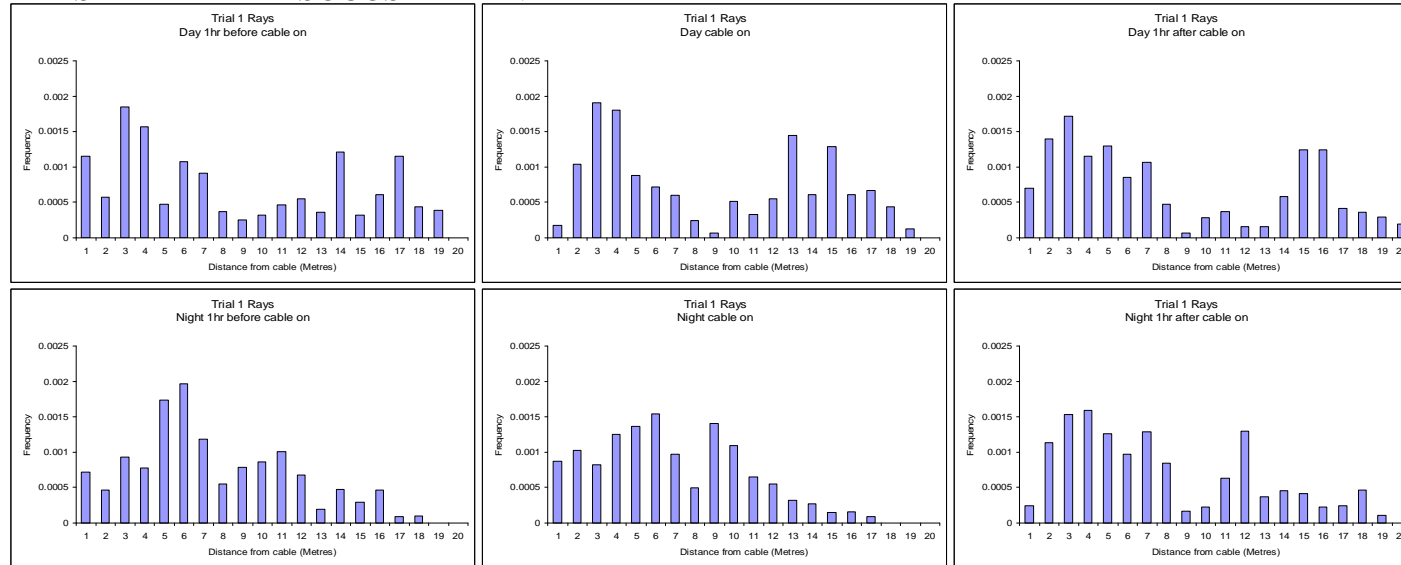
These results show there was a statistically significant difference in the overall data which could have been attributed to Trial number, time of day and or cable on/off. Therefore, we undertook separate pair-wise comparisons of the fish number proportions for the three hour period of before, during and after cable switch on separating the data by day/night and trial number.

There were significantly greater numbers of Catshark within the 2m zone of the live mesocosm either side of the cable when the cable was switched on during the night for Trial 2 compared to the numbers present before and after the cable was energised (Table 5; Figure 8). There was also a significantly greater number of catshark present in the zone during the day for Trial 3 when the cable was switched on compared to afterwards (Table 5; Figure 9). For all other comparisons there was no statistically significant difference (Table 5). This result is important as it demonstrates that there was some behavioural response of being nearer to the cable for one of the species, *S. canicula*, some of the time and is based on both sets of tagged fish (coded and continuous). The response occurred during both the Trials that the Catshark was studied. There was no statistical evidence that the other two species were nearer to the cable during switch on.

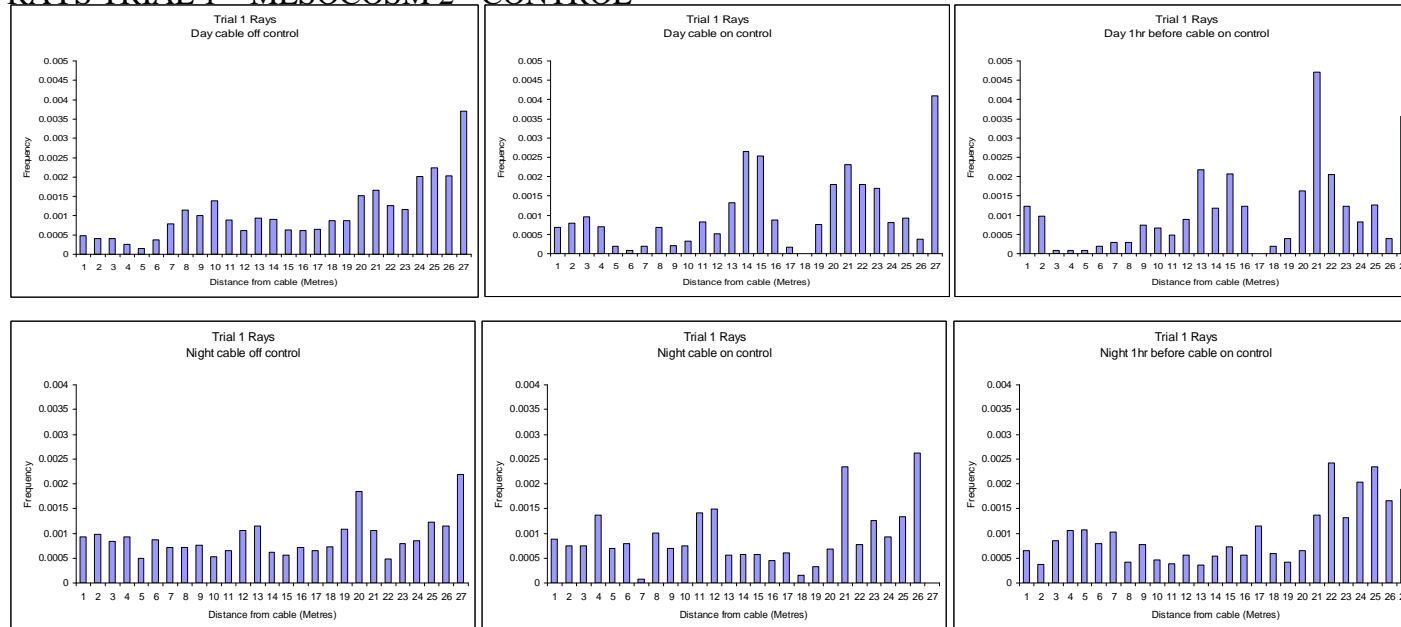
**Table 5.** Two tailed, paired t-tests of standardised fish number proportions (rays, catshark and spurdog) for comparisons between the hour before and the hour during cable switch on and between the period of switch on and the hour afterwards. Bold shaded p values are statistically significant; ‘-’ insufficient data.

		LIVE MESOCOSM								CONTROL MESOCOSM								
		Day				Night				Day				Night				
		Before v On		After v On		Before v On		After v On		Before v On		After v On		Before v On		After v On		
<b>Rays</b>	Trial 1	<i>Mean</i>	22.3	19.3	26.5	19.3	16.0	23.1	23.1	23.1	17.0	13.3	3.18	13.3	11.3	16.9	17.3	16.9
		<i>Variance</i>	988.1	602.3	869.8	602.3	202.2	171.9	962.9	171.9	1001.0	509.3	40.6	509.3	328.8	239.7	470.6	239.7
		<i>df</i>	10		10		9		9		10		10		9		9	
		<i>t statistic</i>	-0.65		-0.85		1.41		-0.001		0.29		-1.46		-0.85		0.07	
		<i>p</i>	0.53		0.41		0.19		0.99		0.77		0.17		0.42		0.94	
Trial 2	<i>Mean</i>	13.7	8.6	7.4	8.6	8.0	8.5	12.1	8.5	6.1	11.0	17.4	11.0	17.1	11.9	20.8	11.9	
	<i>Variance</i>	615.3	55.6	81.7	55.6	118.7	106.2	142.7	106.2	346.0	386.2	806.6	386.2	600.4	374.2	922.3	374.2	
	<i>df</i>	18		18		14		14		18		18		14		14		
	<i>t statistic</i>	0.95		-0.62		-0.17		0.83		-0.80		0.89		1.12		0.83		
	<i>p</i>	0.35		0.54		0.87		0.42		0.43		0.38		0.28		0.42		
Trial 3	<i>Mean</i>	18.2	20.9	22.2	20.9	19.7	21.2	19.5	21.2	30.3	36.0	30.5	36.0	11.4	14.8	24.9	14.8	
	<i>Variance</i>	361.8	363.0	376.4	363.0	249.6	133.0	236.3	133.0	737.1	487.1	634.9	487.1	201.9	358.4	750.6	358.4	
	<i>df</i>	11		11		13		13		11		11		13		13		
	<i>t statistic</i>	-1.02		0.47		-0.30		0.36		-1.19		-0.71		-0.71		1.53		
	<i>p</i>	0.33		0.65		0.77		0.73		0.26		0.50		0.49		0.15		
<b>Catshark</b>																		
Trial 2	<i>Mean</i>	18.7	15.9	19.4	15.9	13.7	24.9	15.6	24.9	8.2	12.2	10.6	12.2	18.2	15.8	18.3	15.8	
	<i>Variance</i>	676.5	507.3	568.7	507.3	286.6	338.1	287.2	338.1	288.2	210.6	163.9	210.6	136.8	40.6	107.9	40.6	
	<i>df</i>	18		18		14		14		18		18		14		14		
	<i>t statistic</i>	1.45		1.62		-2.28		-3.27		-1.24		-0.52		0.72		0.77		
	<i>p</i>	0.16		0.12		<b>0.03</b>		<b>0.005</b>		0.22		0.61		0.48		0.45		
Trial 3	<i>Mean</i>	19.9	28.0	10.3	28.0	25.8	20.3	19.9	20.2	-	-	-	-	-	-	-	-	
	<i>Variance</i>	845.8	344.0	188.2	344.0	270.2	128.1	108.3	128.1									
	<i>df</i>	11		11		13		13										
	<i>t statistic</i>	-1.25		-2.46		1.10		-0.10										
	<i>p</i>	0.24		<b>0.03</b>		0.29		0.91										
<b>Spurdog</b>																		
Trial 1	<i>Mean</i>	5.2	6.9	7.5	6.9	7.2	6.6	-	-	10.1	14.5	15.0	14.5	-	-	-	-	
	<i>Variance</i>	15.4	8.1	13.1	8.1	5.3	5.4			52.4	81.8	57.2	81.8					
	<i>df</i>	10		10		9				10		10						
	<i>t statistic</i>	-1.27		-0.54		0.47				-1.36		0.16						
	<i>p</i>	0.23		0.59		0.64				0.20		0.87						

## RAYS TRIAL 1 – MESOCOSM 1 - LIVE

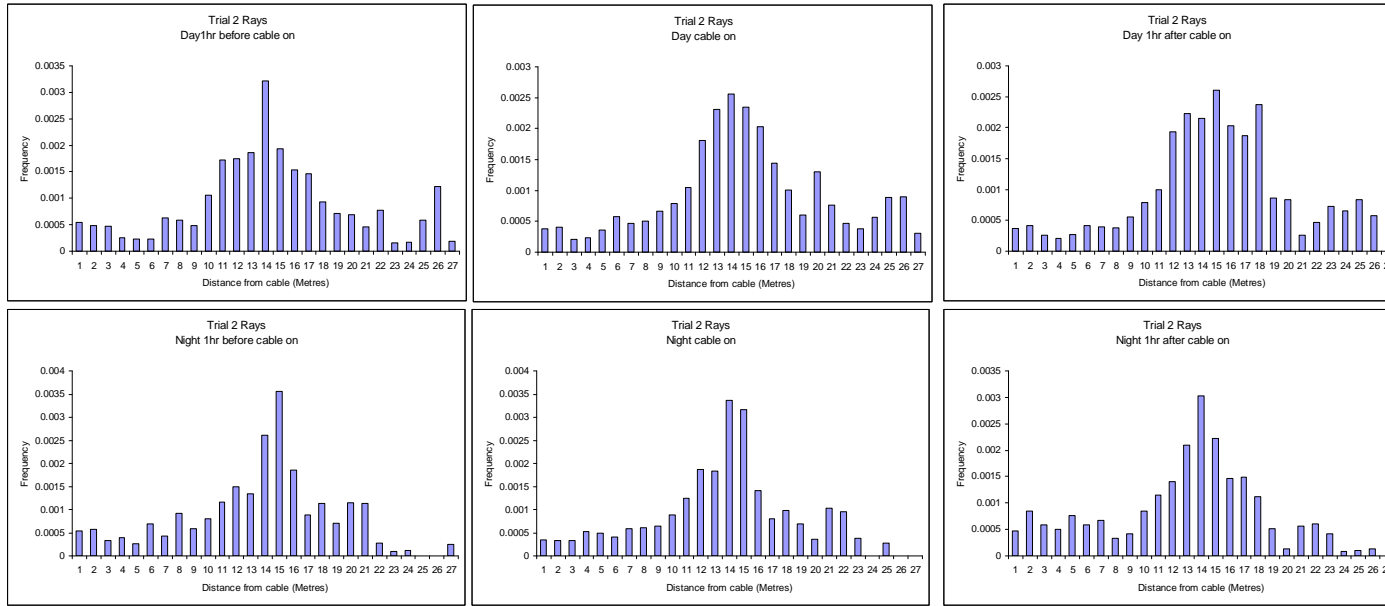


## RAYS TRIAL 1 – MESOCOSM 2 - CONTROL

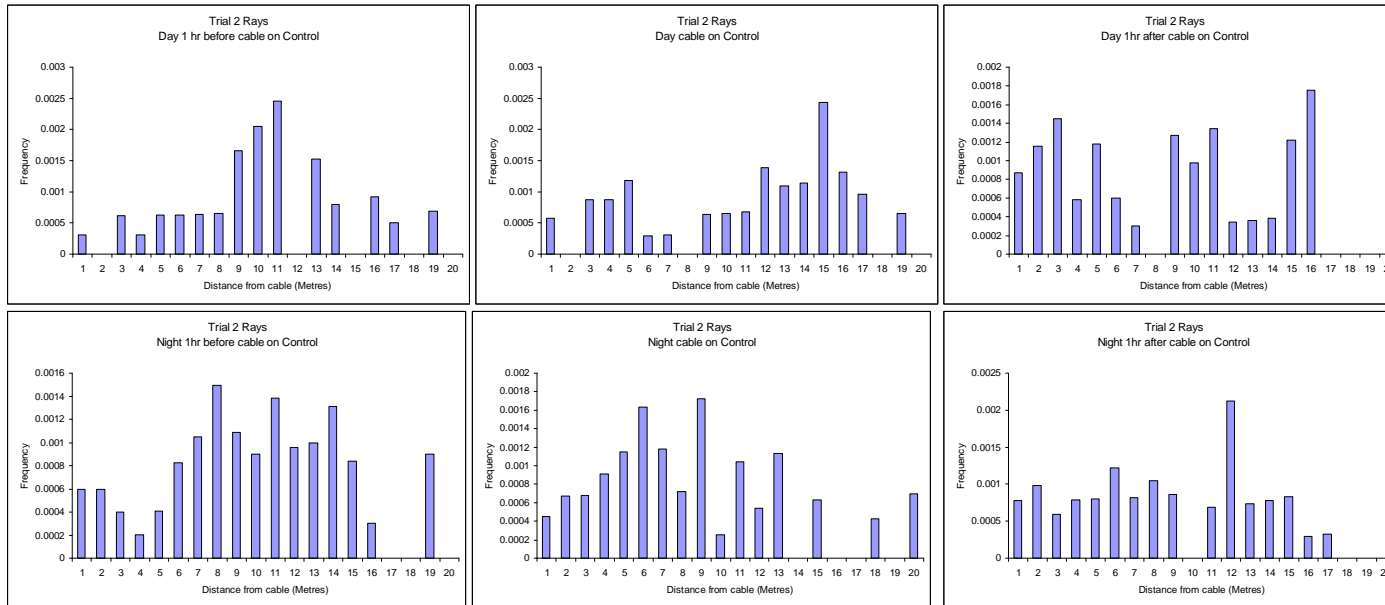


**Figure 5.** Frequency of Ray occurrence at 1m distances from cable axis for live and control mesocosms during Trial 1.

## RAYS TRIAL 2 – MESOCOSM 2 - LIVE

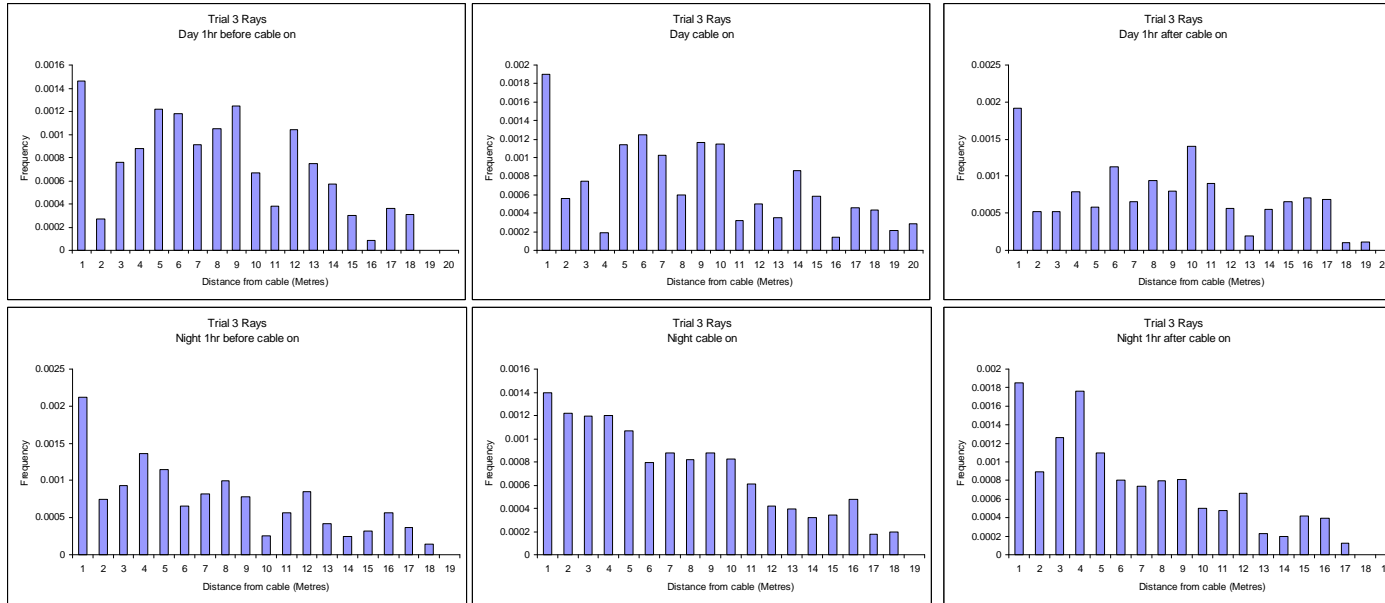


## RAYS TRIAL 2 – MESOCOSM 1 - CONTROL

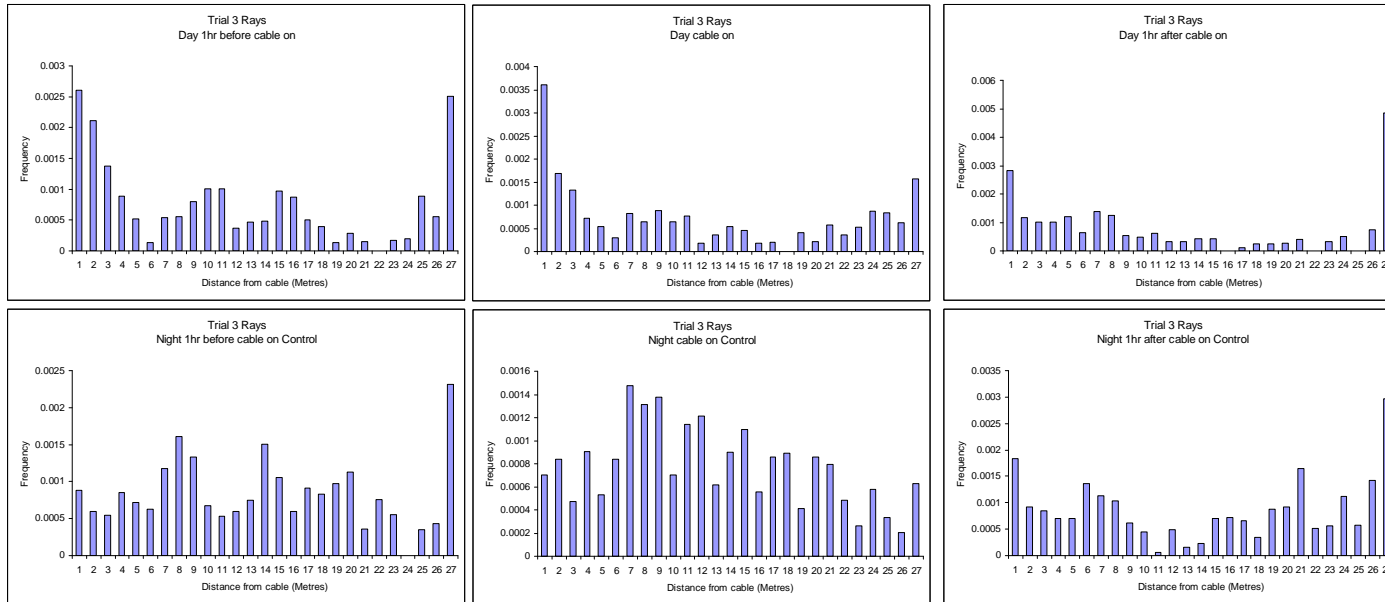


**Figure 6.** Frequency of Ray occurrence at 1m distances from cable axis for live and control mesocosms during Trial 2.

## RAYS TRIAL 3 – MESOCOSM 1 - LIVE

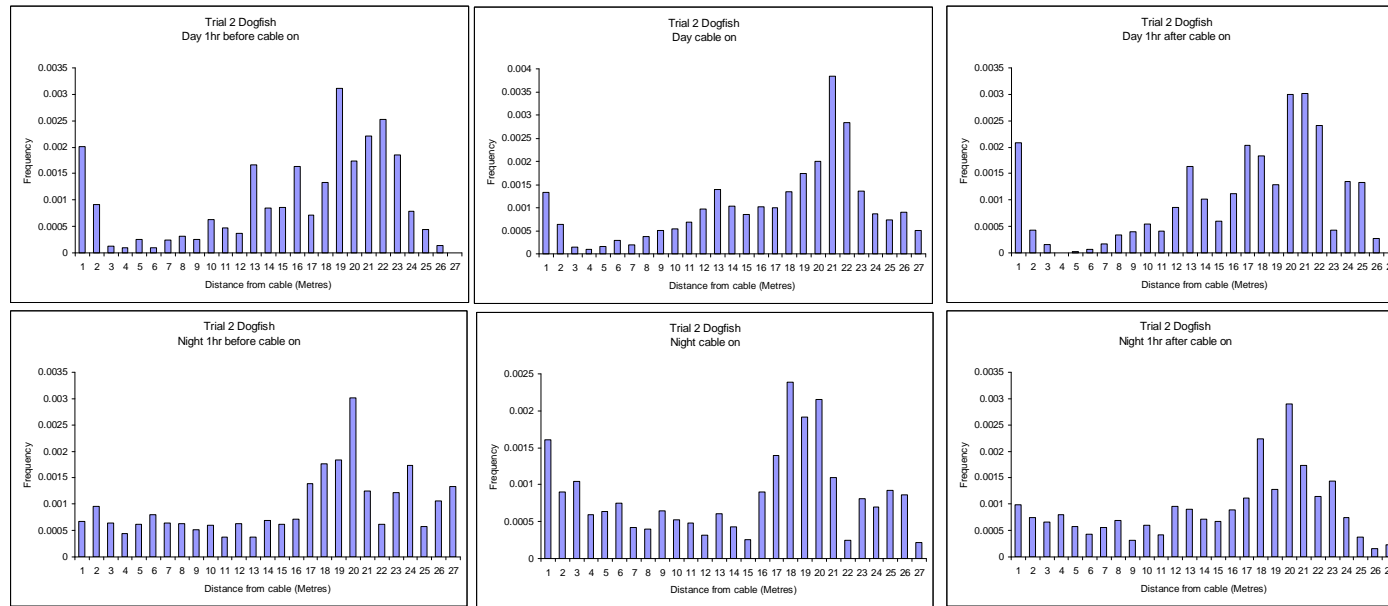


## RAYS TRIAL 3 – MESOCOSM 2 - CONTROL

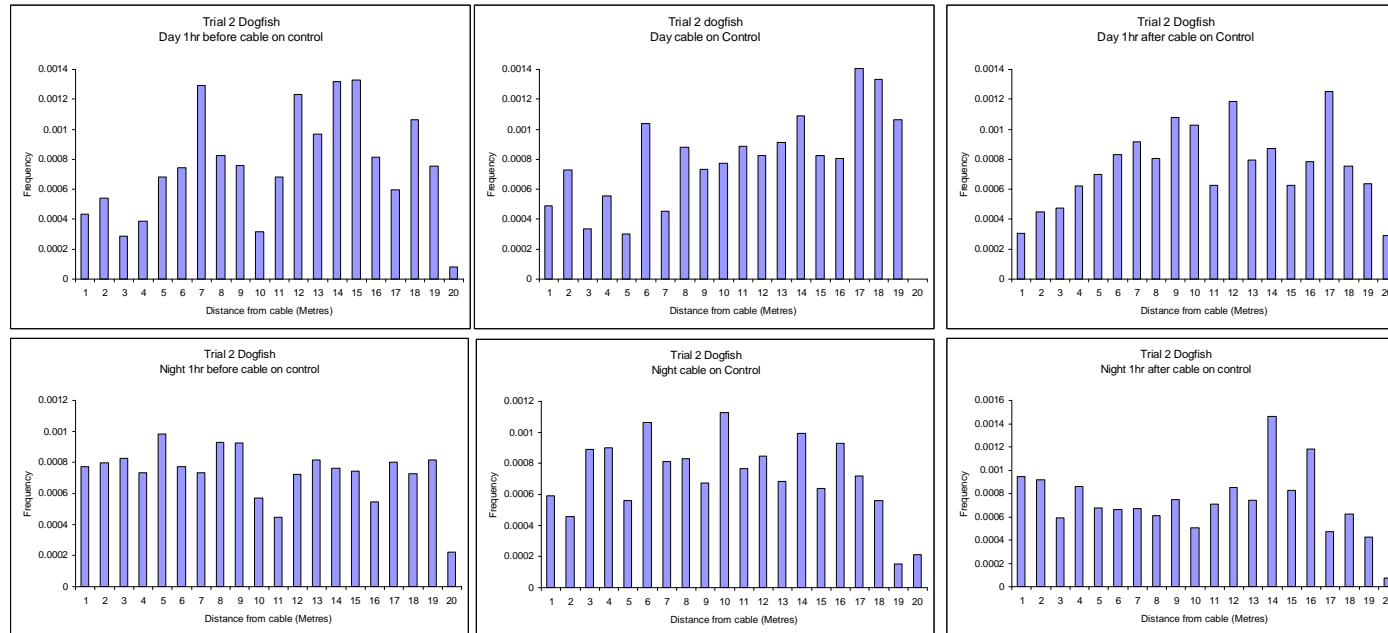


**Figure 7.** Frequency of Ray occurrence at 1m distances from cable axis for live and control mesocosms during Trial 3.

## CATSHARK TRIAL 2 – MESOCOSM 2 - LIVE



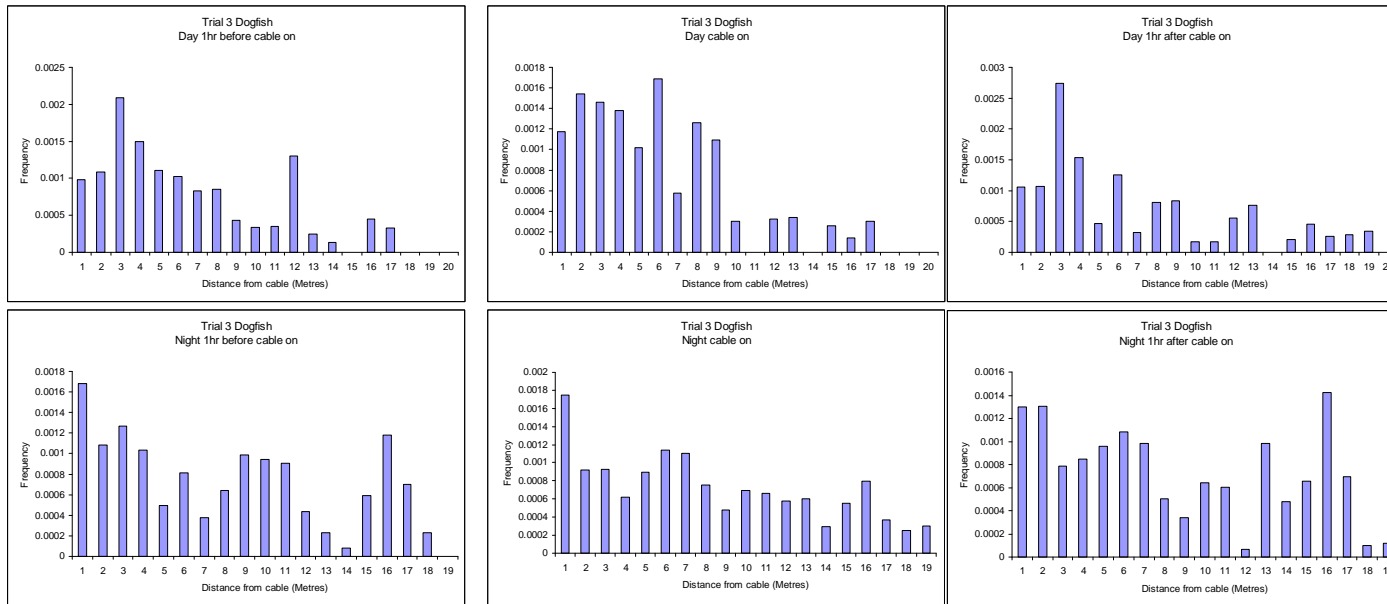
## CATSHARK TRIAL 2 – MESOCOSM 1 - CONTROL



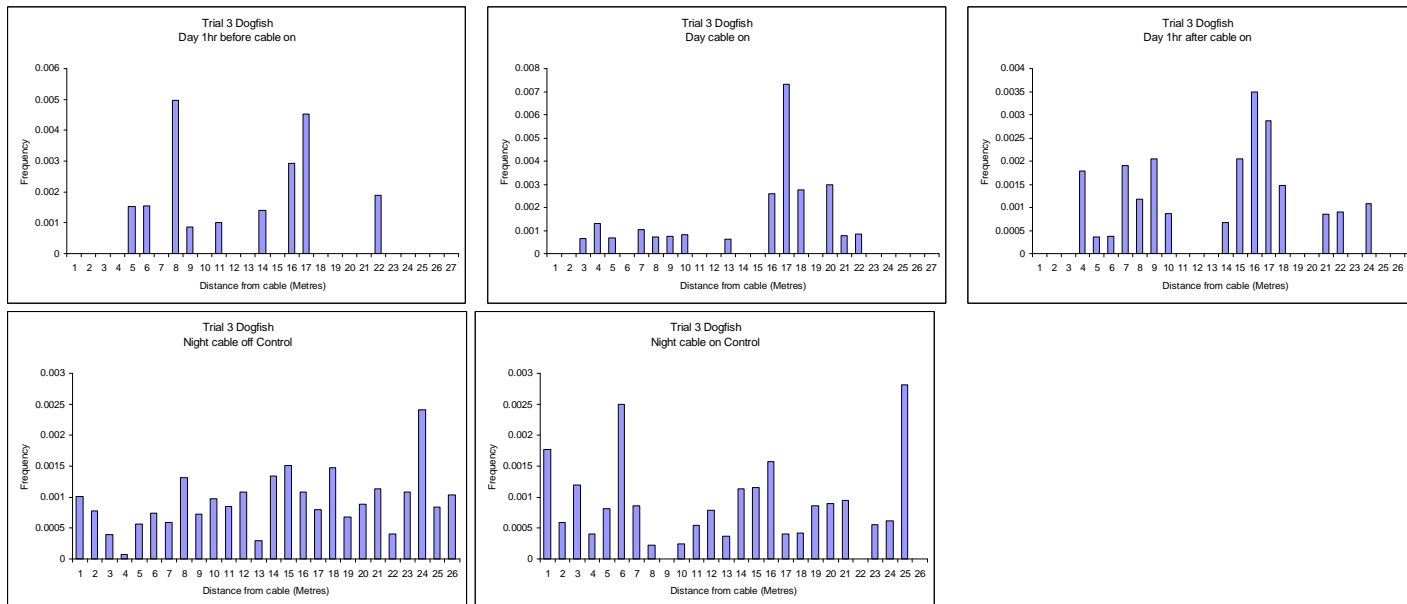
**Figure 8.** Frequency of Catshark occurrence at 1m distances from cable axis for live and control mesocosms during Trial 2.



### CATSHARK TRIAL 3 – MESOCOSM 1 – LIVE

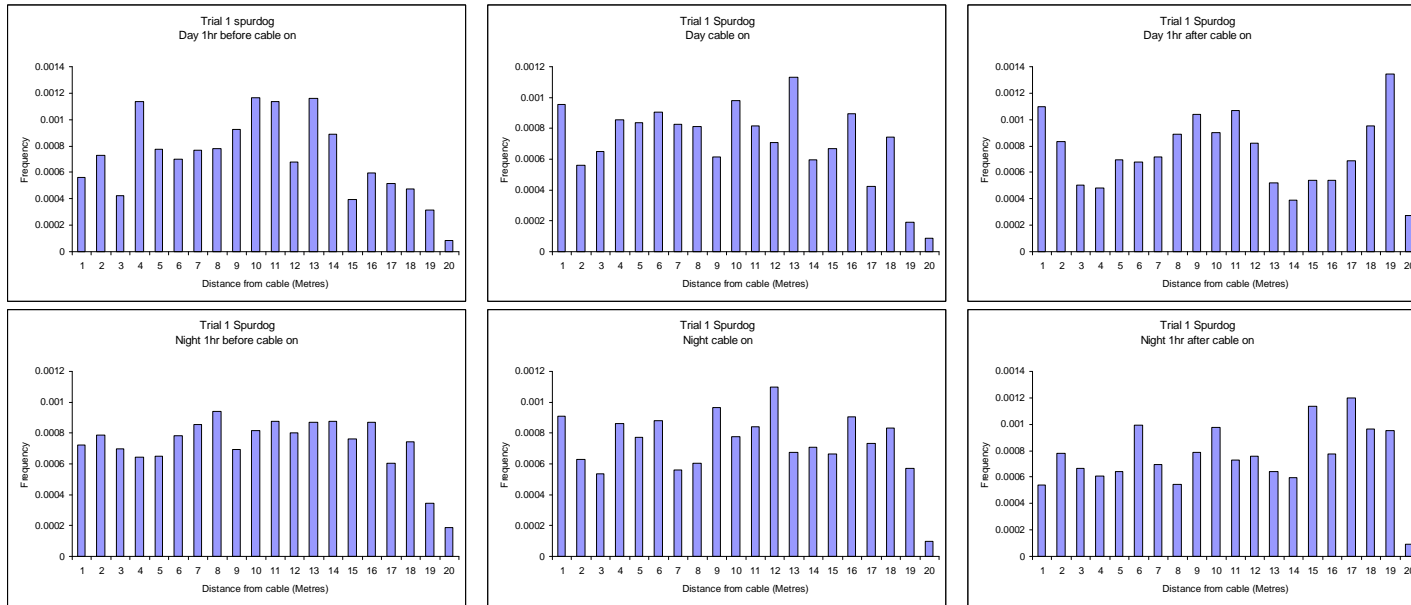


### CATSHARK TRIAL 3 – MESOCOSM 2 – CONTROL



**Figure 9.** Frequency of Catshark occurrence at 1m distances from cable axis for live and control mesocosms during Trial 3.

# SPURDOGS TRIAL 1 – MESOCOSM 1 - LIVE



# SPURDOGS TRIAL 1 – MESOCOSM 2 - CONTROL

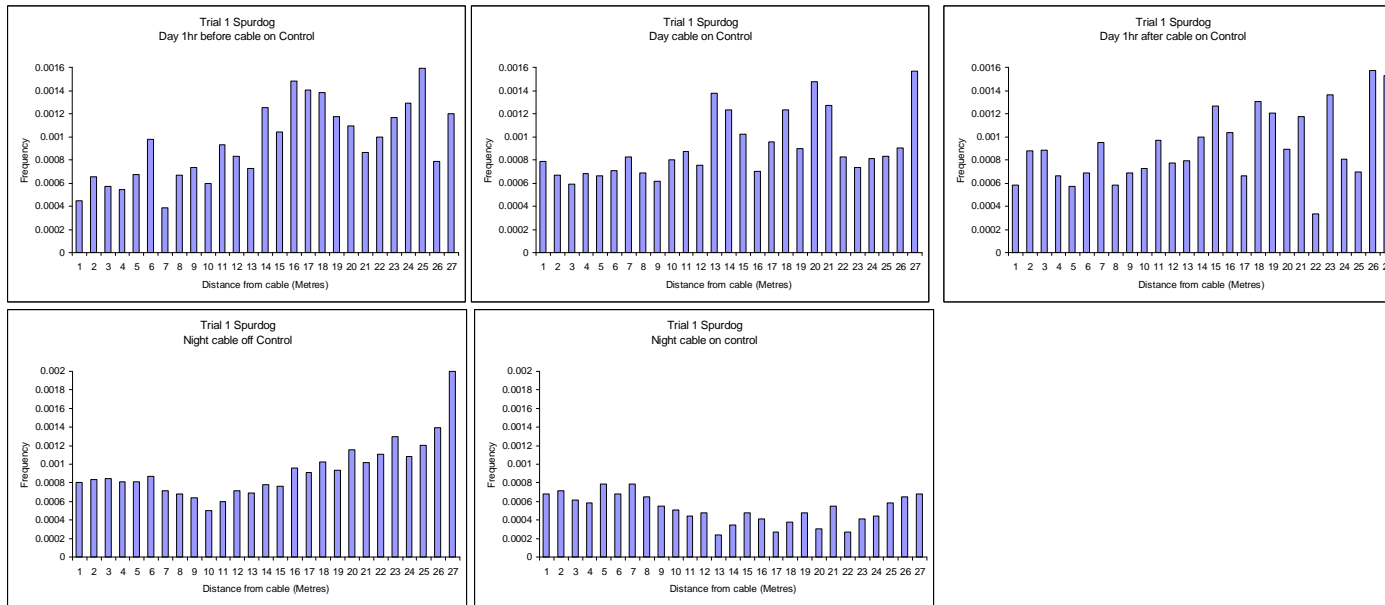


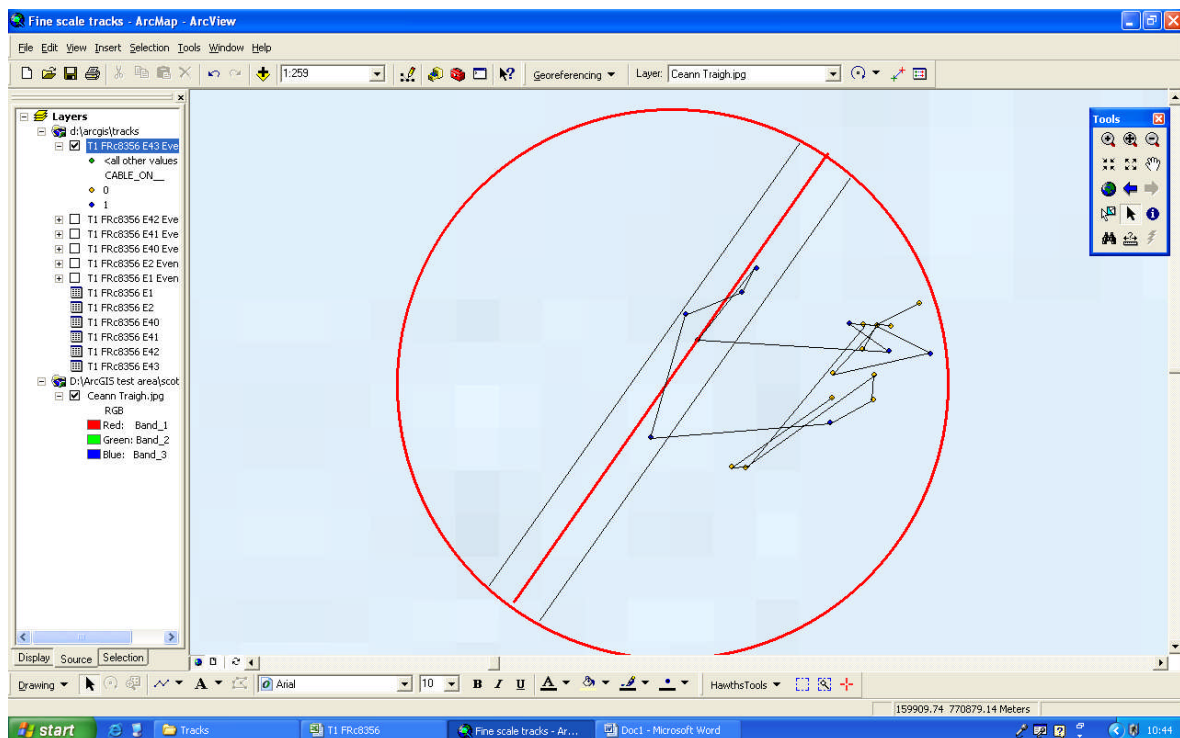
Figure 10. Frequency of Spurdog occurrence at 1m distances from cable axis for live and control mesocosms during Trial 1.

### 6.2.3. Fine scale tracking analysis

To further explain the differences found in the overall study we analysed the fine scale movement responses of the fish fitted with continuous data tags. Not all the continuous data were useable but sufficient events of the fish being tracked before, during and after the cable was turned on, both within the live and the control cages allowed us to analyse the fine scale movements of some of the fish.

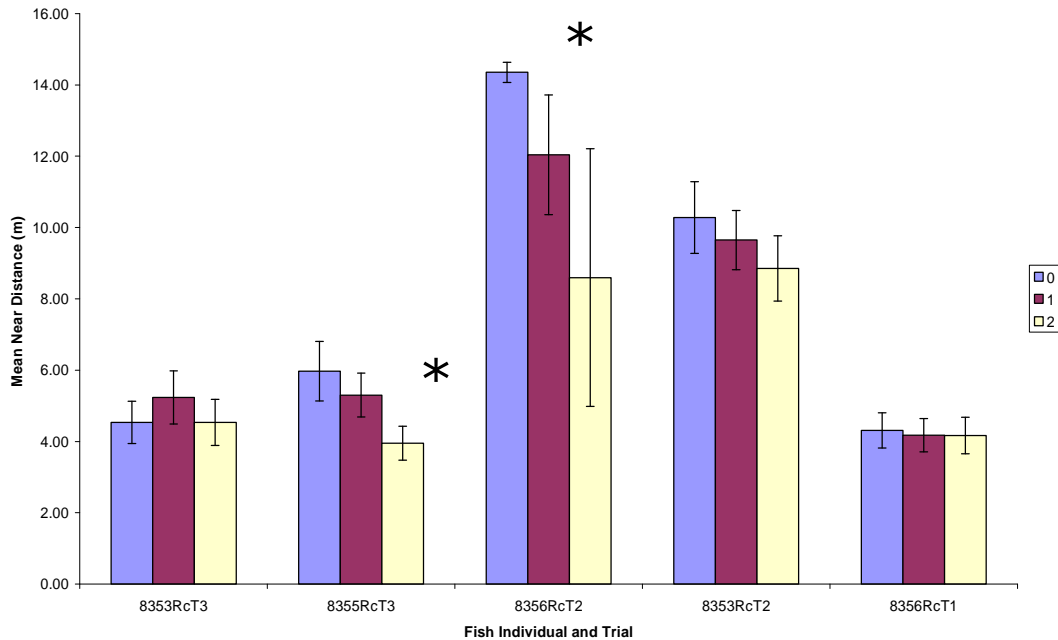
The time between each position fix using the number of deployed continuous tags was estimated at the beginning of the study to be around 2 mins, based on information provided by Vemco ltd. The most frequent time interval that we recorded was 2 mins 26 secs (mode), which provided us with data of movements close to the fine scale we expected.

To analyse these data we again looked at the 2m zone either side of the cable axis for both the live and the control mesocosm. Within ArcGIS we used the ARC Toolbox Proximity Near analysis tool to calculate the distance of each position fix from the line of the cable, which we termed 'Near Distance'. Subsequently, we applied Hawth's Analysis Tools (<http://www.spatial ecology.com/htools/index.php>), an animal movement analysis extension to ArcGIS to determine the straight line distance between each successive position fix, which we termed 'Step Length'. We then extracted a subset of fine scale tracks (see Figure 11 for example), which had at least one position fix within 2m of either side of the line of the cable or tracks of fish that had passed over the cable at some time during the three hours. The reason for doing this was to remove any fish movement that was always outside the 2m zone either side of the cable. Fish outside of this distance were considered to not be able to detect any emission from the cable as the EMF would have dissipated below the minimum E field of  $0.5\mu\text{V}/\text{m}$  that they are able to detect (Kalmijn 1971), hence the fish would have been too far away to detect the EMF present. Some of the fish that did have a position fix within the 2m then moved outside the zone of detection, however we included these in the analysis to ensure that we included all tracking events where a fish at least had the potential to respond to the presence of a field at some point in the period under study.

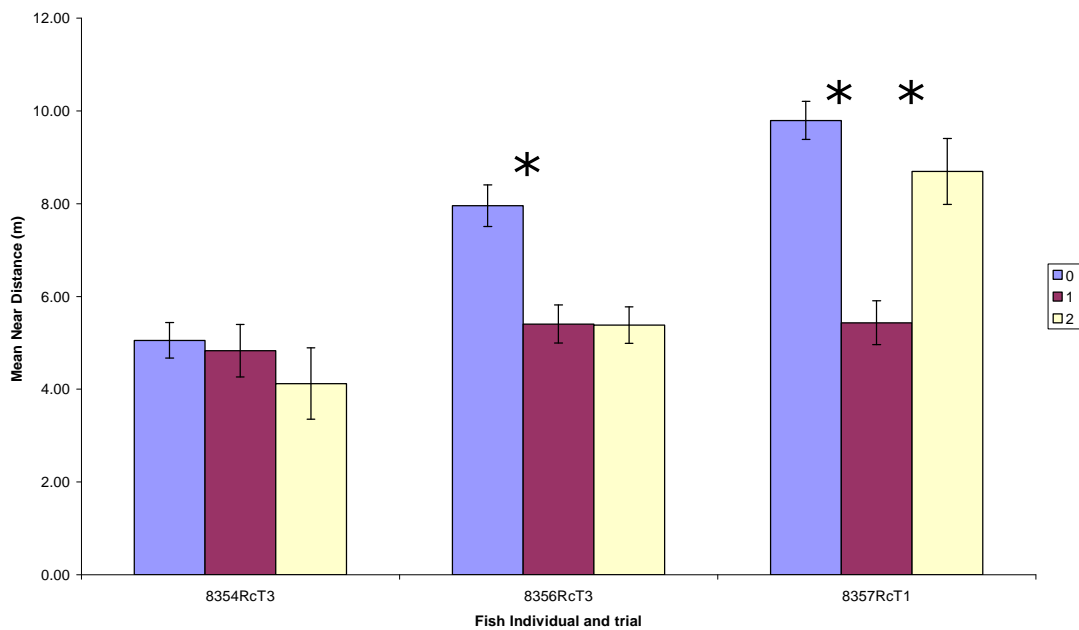


**Figure 11.** Example of an individual Ray movement track during a three hour event. Yellow points show fixes either during the 1 hour before cable turn on or 1 hour after cable turn off. The blue points show positions during the 1 hour period the cable was energised.

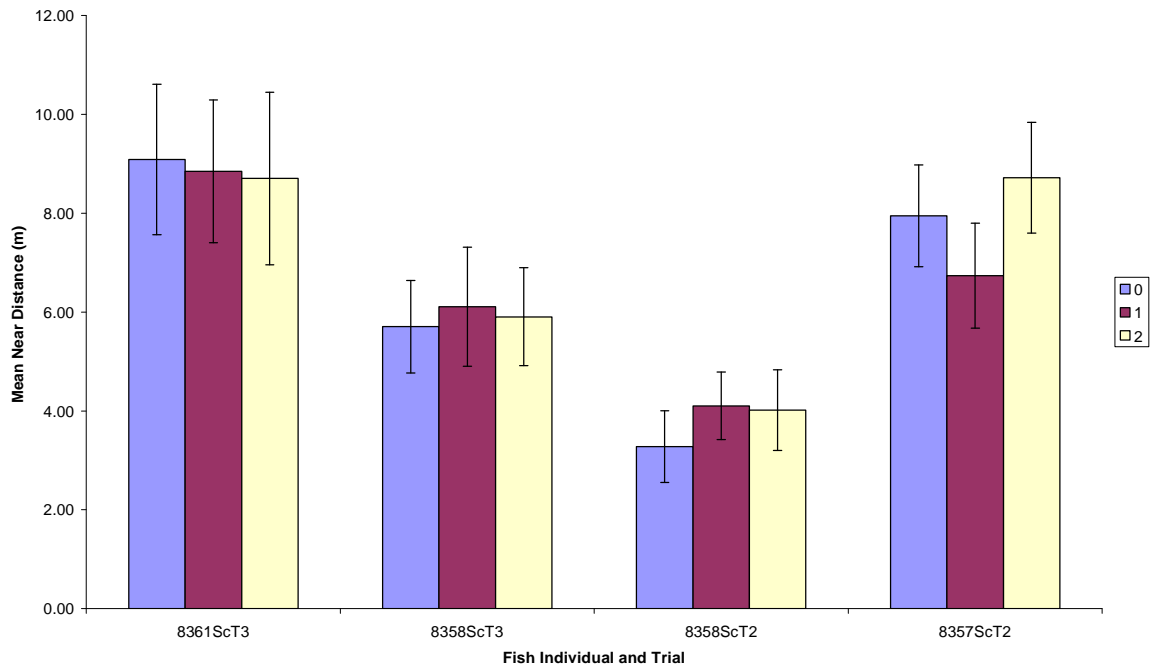
With the sub-set of data obtained we standardised the Step Length to ensure that any time differences between fixes were taken into account. Most fish transmitter position fixes were regular but on some occasions fixes were missed and therefore the time between recorded fixes was longer than other timings. These data are summarised in Figures 12a to 16b, which show the mean Near Distances and the mean Step Length (+/- 95% Confidence Limits) for each species of fish in the live and control mesocosms that provided sufficient data to analyse. Data for the Spurdog Step Length were limited and are therefore not included.



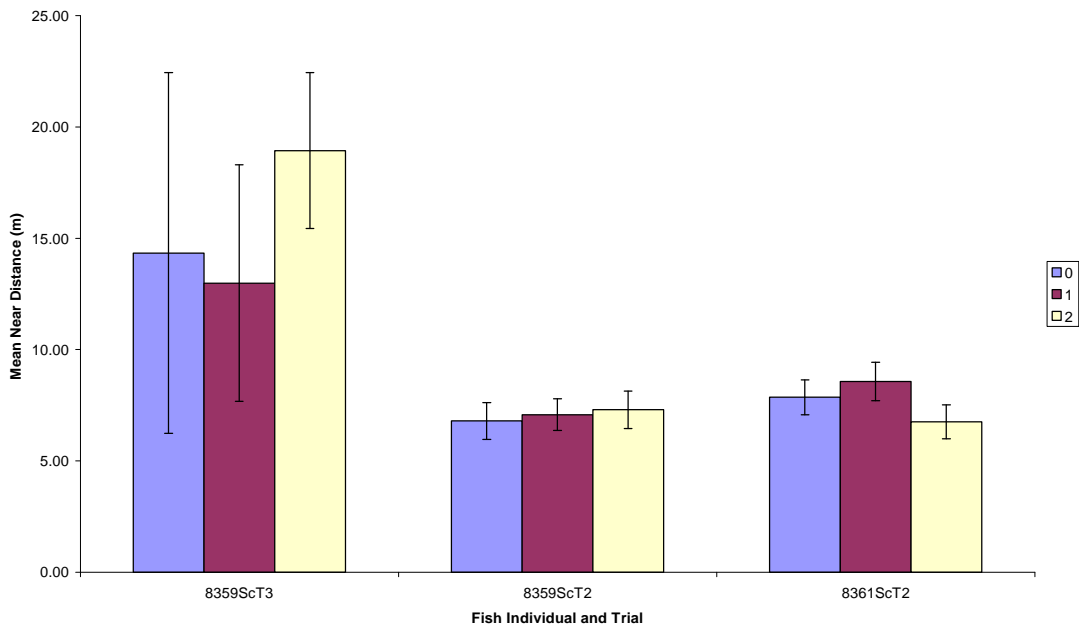
**Figure 12a.** Mean Near Distance (+/- 95% C.L.) of each individual Ray in live mesocosm. 0 = 1 hour before cable turn on; 1 = 1 hour during cable live; 2 = 1 hour after cable switch off.



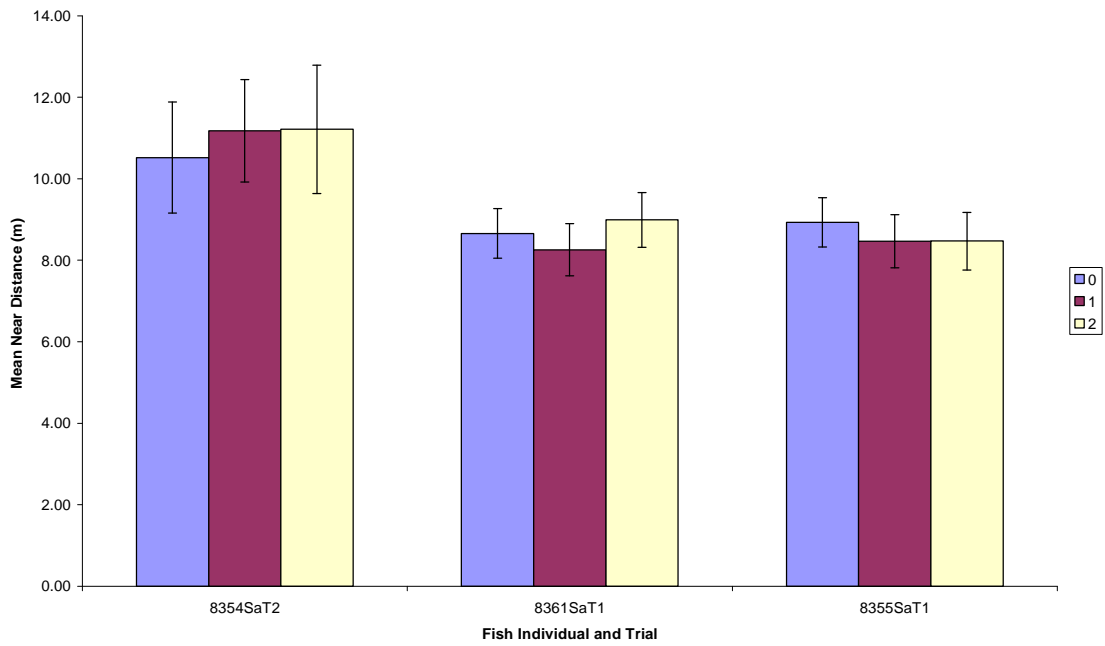
**Figure 12b.** Mean Near Distance (+/- 95% C.L.) of each individual Ray in control mesocosm. 0 = 1 hour before cable turn on; 1 = 1 hour during cable live; 2 = 1 hour after cable switch off.



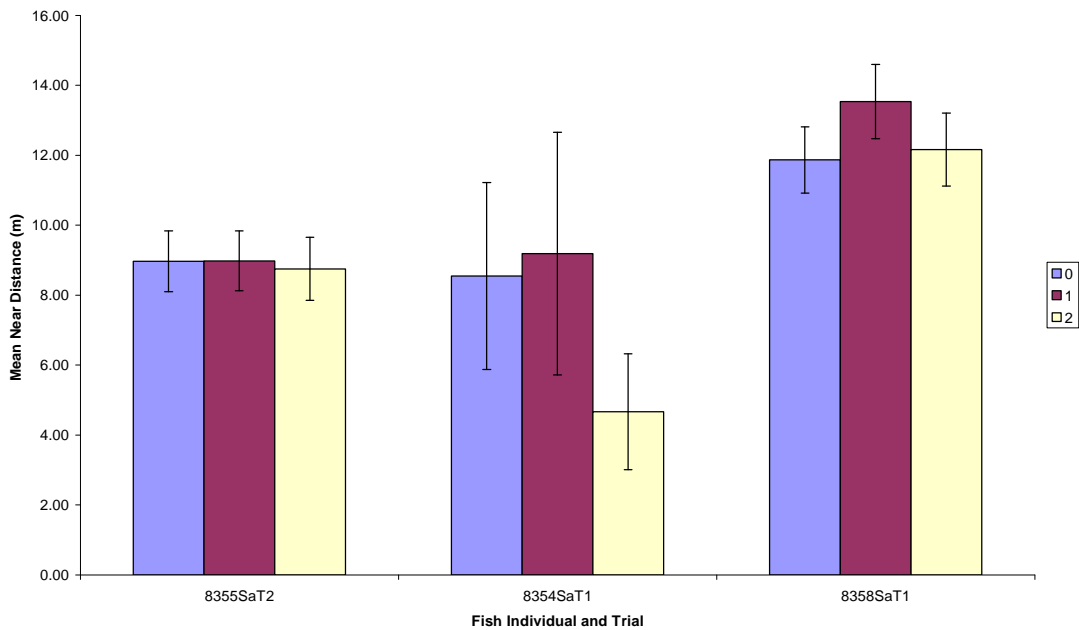
**Figure 13a.** Mean Near Distance (+/- 95% C.L.) of each individual Catshark in live mesocosm. 0 = 1 hour before cable turn on; 1 = 1 hour during cable live; 2 = 1 hour after cable switch off.



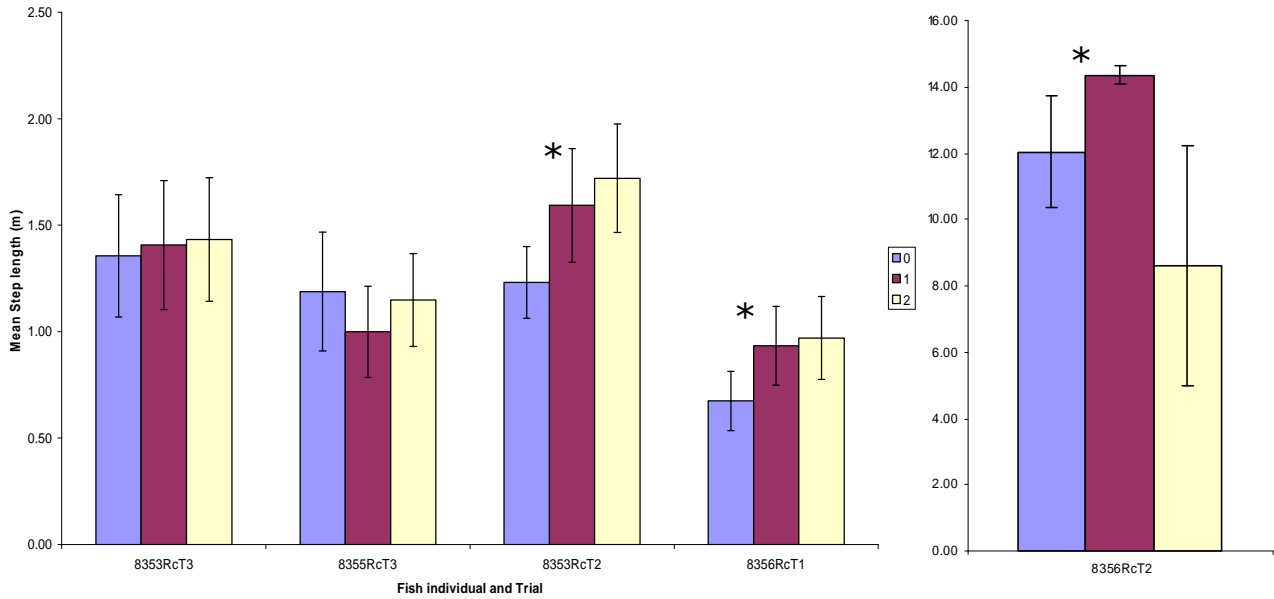
**Figure 13b.** Mean Near Distance (+/- 95% C.L.) of each individual Catshark in control mesocosm. 0 = 1 hour before cable turn on; 1 = 1 hour during cable live; 2 = 1 hour after cable switch off.



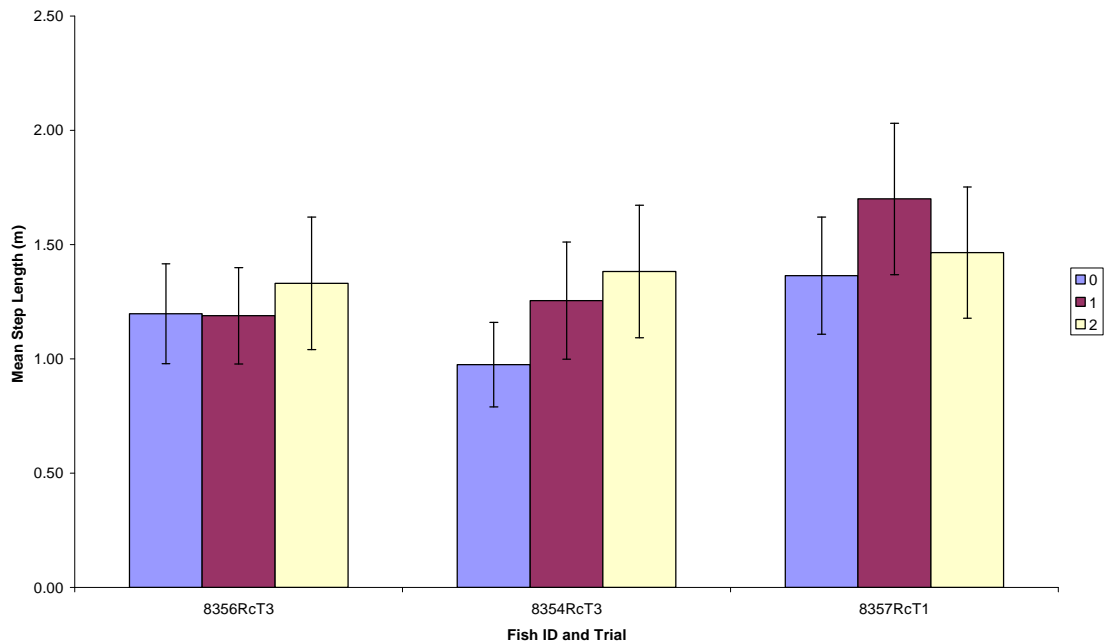
**Figure 14a.** Mean Near Distance (+/- 95% C.L.) of each individual Spurdog in live mesocosm. 0 = 1 hour before cable turn on; 1 = 1 hour during cable live; 2 = 1 hour after cable switch off.



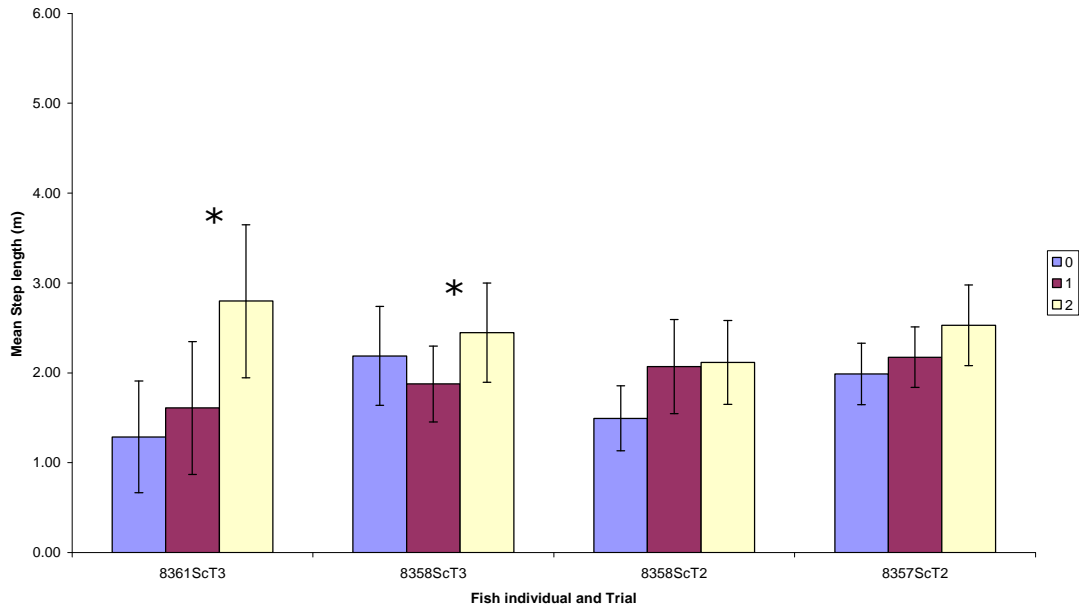
**Figure 14b.** Mean Near Distance (+/- 95% C.L.) of each individual Spurdog in control mesocosm. 0 = 1 hour before cable turn on; 1 = 1 hour during cable live; 2 = 1 hour after cable switch off.



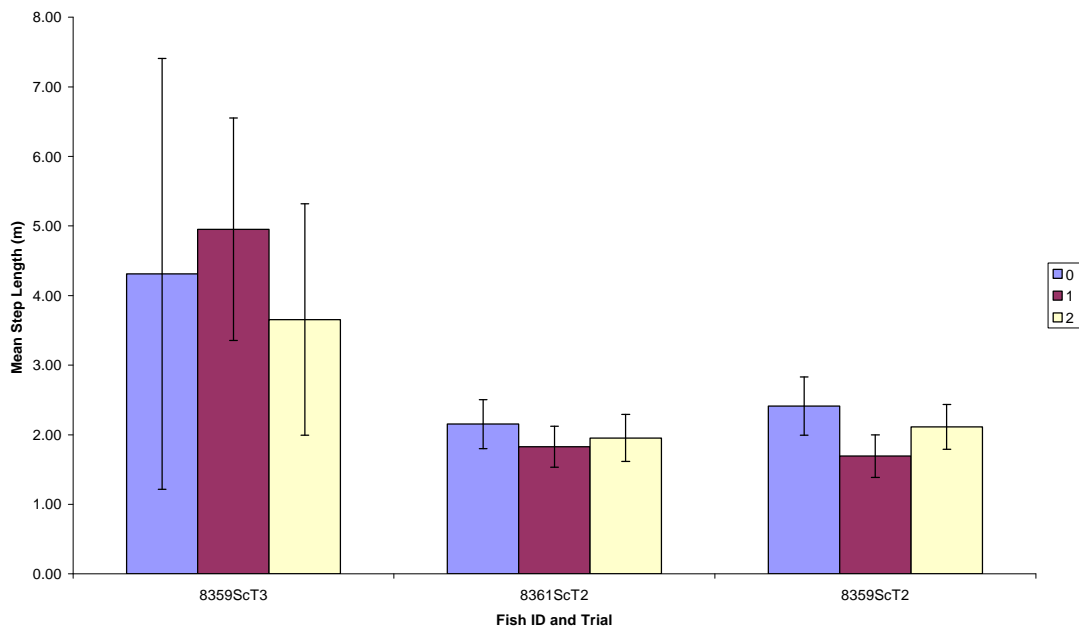
**Figure 15a.** Mean Step Length (+/- 95% C.L.) of each individual Ray in live mesocosm. 0 – 1 hour before cable turn on; 1 – 1 hour during cable live; 2 – 1 hour after cable switch off. One ray is shown on its own owing to the difference in scale values.



**Figure 15b.** Mean Step Length (+/- 95% C.L.) of each individual Ray in control mesocosm. 0 = 1 hour before cable turn on; 1 = 1 hour during cable live; 2 = 1 hour after cable switch off.



**Figure 16a.** Mean Step Length (+/- 95% C.L.) of each individual Catshark in live mesocosm. 0 = 1 hour before cable turn on; 1 = 1 hour during cable live; 2 = 1 hour after cable switch off.



**Figure 16b.** Mean Step Length (+/- 95% C.L.) of each individual Catshark in control mesocosm. 0 = 1 hour before cable turn on; 1 = 1 hour during cable live; 2 = 1 hour after cable switch off.



### *Near Distance*

There were significant differences overall for the **Rays**, Near Distance data both for the live and the control cage (Figure 12a and 12b).

**Rays** Kruskal-Wallis: Live - Chi-sq = 10.62, df = 2, **p = 0.005**  
Control - Chi-sq = 26.59, df = 2, **p < 0.001**

There were no overall differences in the Near Distance data for **Catshark** and **Spurdog** in either the live or the control mesocosms, therefore we did not analyse these two species any further.

**Catshark** Kruskal-Wallis: Live - Chi-sq = 2.71, df = 2, p = 0.258  
Control - Chi-sq = 3.74, df = 2, p = 0.154  
**Spurdog** Kruskal-Wallis: Live - Chi-sq = 0.77, df = 2, p = 0.680  
Control - Chi-sq = 4.36, df = 2, p = 0.113

### *Step Length*

There were significant differences for the **Catshark** and the **Rays** in the live mesocosm in terms of Step Length (Figure 15a and 16a).

**Rays** Kruskal-Wallis: Live - Chi-sq = 19.02, df = 2, **p < 0.001**  
**Catshark** Kruskal-Wallis: Live - Chi-sq = 24.12, df = 2, **p < 0.001**

There were no overall differences in the Step Length data for **Catshark**, **Rays** or **Spurdog** in the control mesocosms nor in the live mesocosm for **Spurdog**. Therefore we did not analyse these data any further.

**Rays** Kruskal-Wallis: Control - Chi-sq = 1.84, df = 2, p = 0.339  
**Catshark** Kruskal-Wallis: Control - Chi-sq = 4.29, df = 2, p = 0.117  
**Spurdog** Kruskal-Wallis: Live - Chi-sq = 2.92, df = 2, p = 0.232  
Control - Chi-sq = 1.98, df = 2, p = 0.372

We expected differences may show up owing to the individual variability in response between fish, as shown in Figures 12a to 16b. However, we were particularly interested in whether there were any differences in the distance away from the cable (Near Distance) and the rate of movement (Step Length) as a result of the cable being energised or not. We undertook separate non-parametric Mann-Whitney U-tests on the data for one hour before switch on versus the hour energised and then the hour after turn off. We used the number of fish as the fixed factor which is conservative in terms of degrees of freedom (Dytham 2003) but we regarded this as another way to reduce any effects of serial dependency in the data and be conservative in our analysis.

For the data sets that showed an overall significance we looked at any differences in the Near Distance and Step Length when the cable was on and off, either before or after the energising of the cable. Table 6 and Figures 12a to 16b show that there were a number of significance differences.

For the Rays there were significant differences in the distance away from the cable for two out of the five Rays tracked in the live mesocosms when the cable was on (Figure 12a). One of these Rays, 8353RcT2, was significantly nearer than before switch on of the cable. The other Ray, 8355RcT3 was nearer to the cable in the hour after it was switched off. A suggestion could be made, based on these results and Figure 12a, that the fish were nearer to the cable when switched on or immediately after switch off. However, the control study highlights significant differences in the distance away from the cable, again for two Ray individuals (Table 6; Figure 12b). The data suggest that the fish in the control mesocosm were also nearer to the cable area during the time that the cable was switched on in the other mesocosm. The results for the Near Distance analysis for Rays are therefore inconclusive.

In terms of the Step Length data two species, Rays and Catshark, responded significantly and these were only in the live mesocosm (Table 6). The Step Length (ie. the rate of movement) was significantly greater for three out of five Ray individuals (8353RcT2, 8356RcT1 and 8356RcT2) when the cable was switched on (Figure 15a). There were no differences in the control data set; this therefore suggests that the Rays moved more when the cable was on.

The Catshark moved significantly more after the cable was switched off (Figure 16a). Two individuals out of four (8361ScT3 and 8358ScT3) showed this increased movement however there appears to be some consistency in response for all individual Catshark, particularly in comparison to the control data (Figures 16a and 16b).

**Table 6.** Mann-Whitney statistical tests for individual fish comparing the Near Distance and Step Length data during cable on time with the hour before and the hour after cable switch on.

Response variable	Fish Individual	LIVE		CONTROL	
		Before v On	After v On	Before v On	After v On
<b>Near Distance</b>					
Rays - Live	8355Rc Trial 3	z = -0.360	z = -2.55		
		p = 0.764	<b>p = 0.011</b>		
	8353Rc Trial 3	z = -1.058	z = -1.091		
		p = 0.290	p = 0.275		
	8356Rc Trial 2	z = -2.232	z = -0.219		
		<b>p = 0.026</b>	p = 0.235		
	8353Rc Trial 2	z = -1.248	z = -1.436		
		p = 0.804	p = 0.151		
	8356Rc Trial 1	z = -0.485	z = -0.124		
		p = 0.628	p = 0.901		
Rays - Control	8354Rc Trial 3			z = -1.027	z = -1.690
				p = 0.304	p = 0.091
	8356Rc Trial 3			z = -2.958	z = -1.511
				<b>p = 0.003</b>	p = 0.131
	8357Rc Trial 1			z = -3.717	z = -3.298
				<b>p &lt; 0.001</b>	<b>p = 0.001</b>
<b>Step Length</b>					
Rays - Live	8355Rc Trial 3	z = -0.546	z = -1.615		
		p = 0.585	p = 0.106		
	8353Rc Trial 3	z = -0.001	z = -1.194		
		p = 0.999	p = 0.232		
	8356Rc Trial 2	z = -2.912	z = -0.529		
		<b>p = 0.004</b>	p = 0.557		
	8353Rc Trial 2	z = -2.051	z = -1.647		
		<b>p = 0.04</b>	p = 0.100		
	8356Rc Trial 1	z = -2.170	z = -0.215		
		<b>p = 0.03</b>	p = 0.830		
Cat shark - Live	8358Sc Trial 3	z = -0.518	z = -2.075		
		p = 0.604	<b>p = 0.038</b>		
	8361Sc Trial 3	z = -0.786	z = -2.311		
		p = 0.432	<b>p = 0.021</b>		
	8358Sc Trial 2	z = -1.211	z = -1.422		
		p = 0.226	p = 0.155		
	8357Sc Trial 2	z = -1.128	z = -1.416		
		p = 0.103	p = 0.157		

#### 6.2.4. Data Storage Tags

Within the GIS, the position of each fish carrying a DST an hour prior to and during each cable switch on was plotted. We only looked at data for fish that were located within 2m of the cable and therefore be in the EMF zone so that we could determine any depth related response at the time of switch on. We had poor recovery of the DST from the fish and the data did not provide any results that could be linked to the experimental switching on or off of the cable.

The only conclusion that we could make was that the fish did not move up in the water column as a result of encountering the EMF emitted by the cable. The results are provided in Appendix 2 for reference.

## 7. Assessing the significance of mesocosm study results

The original COWRIE 2.0 EMF project specification highlighted that the study was to focus on any 'adverse' effects of EMF on elasmobranchs used in the study. We suggested early in the project that this was too narrow as it did not consider neutral or any potential beneficial effects, such as if EMF itself was not detrimental to the fish then it could keep them within the wind farm array thereby providing refuge from fishing or enhancing feeding opportunities. Hence, our interpretation of the behavioural results took this more objective approach to determine the following:

- There is evidence that the benthic elasmobranchs species studied did respond to the presence of EMF emitted by a sub-sea cable.
- However, this response was variable within a species and also during times of cable switch on and off, day and night.
- The Kernel Density Probability Function (KDPF) analysis showed that all the fish species moved throughout the mesocosms regardless of whether there was any EMF present or not. There was a predominance of movement towards the offshore side of the mesocosms.
- Analysis of the overall spatial distribution of fish within the mesocosm was non-random and one species, *S. canicula* (the Small-spotted Catshark) was more likely to be found within the zone of EMF emission during times when the cable was switched on.
- The fine scale analysis was limited by the tracking technology available which meant the number of fish individuals studied was low. However, there were differences found for some individuals of Rays and Catshark in terms of their rate of movement around the zone of EMF emission when the cable was switched on.
- There appeared to be a response by the Rays of being nearer to the cable when it was turned on; however a similar response was found in the control mesocosm. This highlights the importance of including the control in the study. But their Step Length was higher once the cable was switched on.
- Taking the overall and fine scale analyses together suggests that the Catsharks will at times be found more of the time near to the energised cable and they will be moving less than during times when the cable is not switched on.
- There was no depth related movement during the time that the cable was on or off.
- There did not appear to be any differences in the fish response by day or night or over time.
- Whilst the results clearly showed individual differences to the EMF there were insufficient occurrences of individuals responding consistently over time for any determination of habituation. Further study on more individuals would be required.

Overall, the mesocosm study provided evidence that the benthic, elasmobranch species studied can respond to the presence of EMF that is of the type and intensity associated with sub-sea cables. The response we recorded was not predictable and did not always occur; when it did it appeared to be species dependent and individual specific, meaning that some species and their individuals are more likely to respond by moving more or less within the zone of EMF. The main result of catshark being found nearer to the cable and moving less is consistent with the area restricted searching that is associated with feeding in benthic Catsharks. The responses of some Ray individuals suggest a greater searching effort during cable switch on. After the cable was turned off some individual Rays did not return to their pre-EMF encounter behaviour which could be a result of the fish response to the EMF stimuli overlapping with the period immediately afterwards.

## 8. EMF Measurements at Operational Wind Farms

As there was no reliable information on *in situ* EMFs at offshore wind farm sites available we considered it important to visit operational wind farms to obtain *in situ* measurements of the EMF.

To draw direct comparison between the EMF emitted within the mesocosms at Ardtoe and the EMF emitted by wind farm cables we used the same dataloggers that were deployed within the mesocosm set up with additional measurements using the hand held probes developed for previous projects. The final mesocosm experiment did not finish until mid-December and CIMS had to transport the dataloggers from the Ardtoe field site back to Liverpool University where the data were download, serviced and reset for redeployment during January and February 2008.

Once the dataloggers were ready, CMACS arranged with the operators of the North Hoyle (npower) and Burbo Bank (Seascope Energy) wind farms to take EMF (both magnetic and electric field) measurements and to obtain the log for the turbine operation and maps with coordinates showing the export cable(s). EMF measurements were obtained although poor weather and strong tides and waves curtailed some days of recording.

This section reports on the field work and also compares the actual magnetic (B) and induced Electric (iE) fields measured at Ardtoe with those predicted in advance of the experimental mesocosm work. The work is reported in the order that it took place; whilst it would have been desirable to have measured EM Fields at offshore wind farm locations prior to the experimental work at Ardtoe this was not possible within the budget and timeframe of the project.

### 8.1. Overview

As described in Section 5.3, modelling was used to determine the appropriate current load to produce an iE field of the desired magnitude in the experimental mesocosms at Ardtoe. The target iE field was between 0.5 and 100 $\mu$ V/m. This range was chosen primarily for two reasons:

1. Modelling of cables used to export power to shore from existing offshore wind farms at North Hoyle and Kentish Flats predicted that iE fields would lie in this range (Gill *et al.* 2005);
2. This is the range of field strengths from sub-sea cables that were believed to be potentially attractive to elasmobranchs (Gill and Taylor 2001).

The modelling predicted that for the cable to be deployed at Ardtoe a current load of 170A would produce a B field of 20 $\mu$ T and an iE field of 61.5 $\mu$ V/m. During the experiment a current load of 100A was the maximum available with the set up used. For comparison, a current load of 100A would produce a B field of 12 $\mu$ T and an iE field of 36 $\mu$ V/m, also within the target range for both B and iE fields.

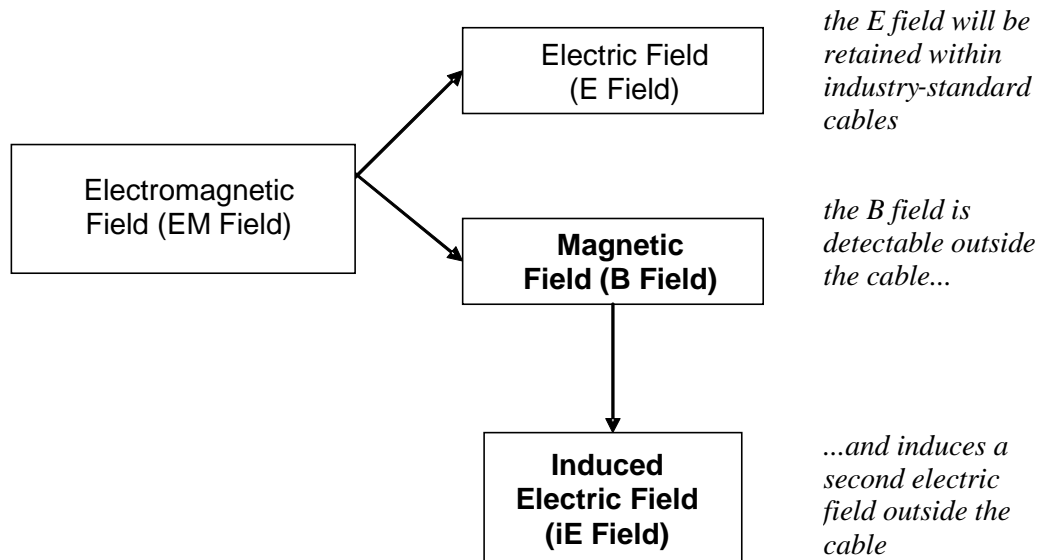
Before addressing the results of EMF measurements it is useful to review the theoretical background to EM Fields and introduce terminology that is used.

The following is an extract from the COWRIE Stage 1.5 report (Gill *et al.* 2005):

“EMF (upper case letters) is standard nomenclature within the electrical engineering profession and electricity industry for the electromagnetic field. However, throughout the course of this project there has been some confusion about the term EMF. The electromagnetic field has been confused with the resultant (induced) electrical field and the fact that there are two fundamentally different fields (electric and magnetic fields) present has often been overlooked. In addition, emf (lower case letters) is also a fundamental electrical acronym, standing for electromotive force which is measured in Volts. This has sometimes resulted in some unnecessary confusion when communicating about EMF.

We suggest that for clarity any future COWRIE publication or communication should use EMF to describe only the direct electromagnetic field, in line with the standard electrical terminology. The two constituent fields of the EMF should be clearly defined as the E (Electric) field and the B (Magnetic) field, whilst the induced electric field should be labelled (iE field).

Figure 1 provides a highly simplified overview of the fields associated with industry-standard submarine power cables, highlighting the magnetic and induced electrical fields that are of interest to the present study:



**Figure 17.** Simplified overview of how induced electrical fields are produced by AC power cables.”

It should be noted that the term B field referred to above and elsewhere is technically termed the ‘magnetic flux density’. The magnetic flux density is the product of the magnetic field (H) and the permeability of the medium in which the field is present ( $\mu$ ). Therefore, the B and H field are the same when the constant  $\mu = 1$ . B field is generally used as it takes account of the permeability of the medium.

## 8.2. Offshore Wind Farm Sites

It was important that initial measurements of EMF at offshore wind farm sites were relatively close to Liverpool (from where the measurement equipment was deployed) so that the highly novel sensors and their data could be downloaded, checked and, if necessary adjusted in the laboratory.

Time was limiting since the dataloggers used at Ardtoe and required for *in situ* measurements were in use at the mesocosms until December with data downloading and servicing taking place through January and early February. These factors, together with budgetary constraints meant that *in situ* measurements were limited to the two wind farms closest to Liverpool, Burbo Bank and North Hoyle. It was hoped that additional measurements could be made at Barrow wind farm or Kentish Flats but there was insufficient time and resources at the end of the programme to incorporate either of these sites.

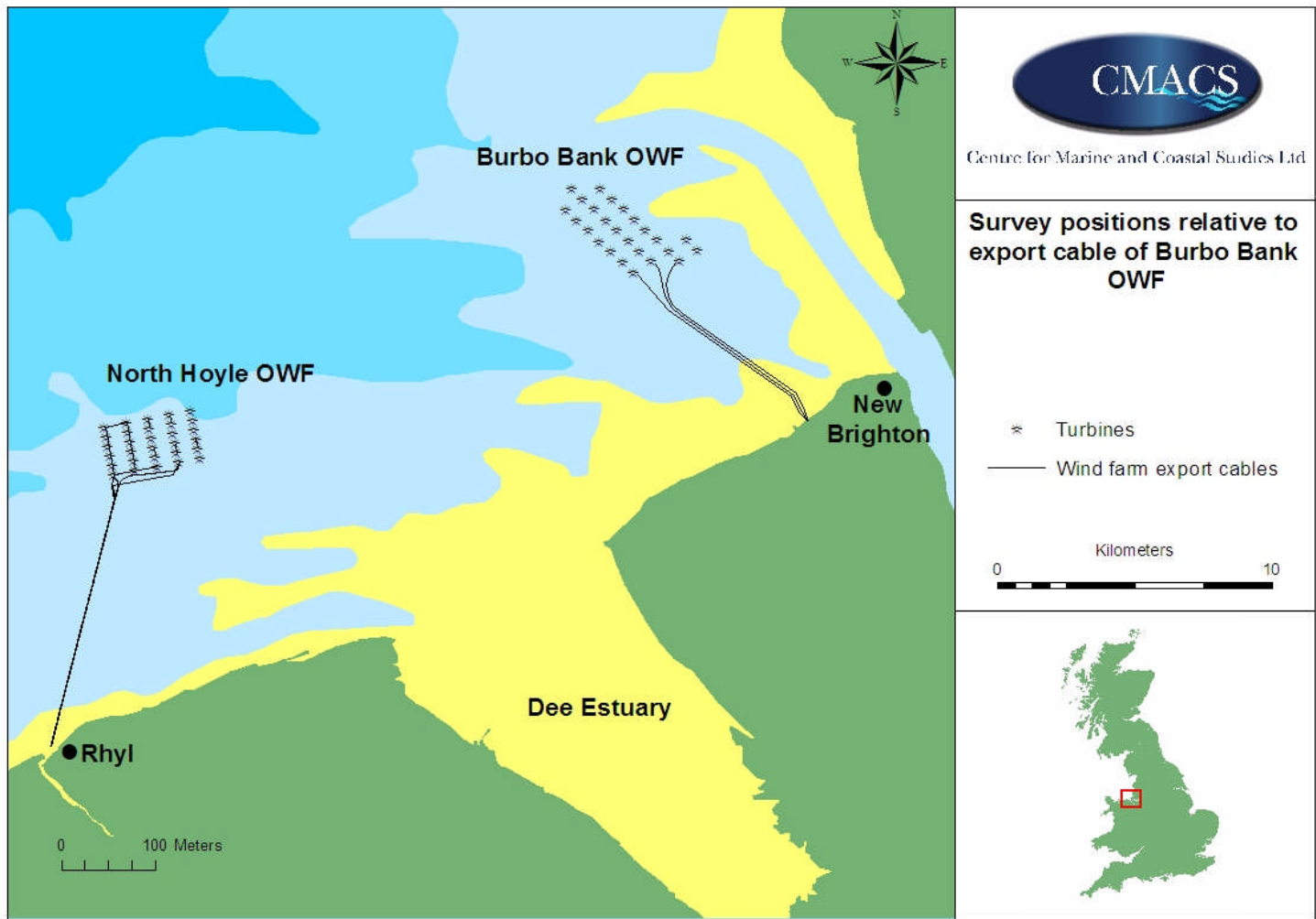
Burbo Bank and North Hoyle are both in Liverpool Bay (Figure 18). North Hoyle was the first major offshore wind farm to be built in the UK and became operational in 2004. Burbo Bank became operational in 2007. Both farms can generate up to 90MW of power under optimal conditions. Power from North Hoyle is exported to a landfall at the coastal town of Rhyl via two cables; Burbo exports power to the North Wirral foreshore near Wallasey via three cables. Details of these cables and their installation are provided below.

Figure 19 gives a cross-sectional view of a typical cable used in wind farm applications. The three export cables for the Burbo Bank wind farm are 50Hz AC rated up to 36kV with three copper conductors. The cross-sectional area of each cable is 500mm<sup>2</sup>. Each cable is XPLE insulated and steel armoured.

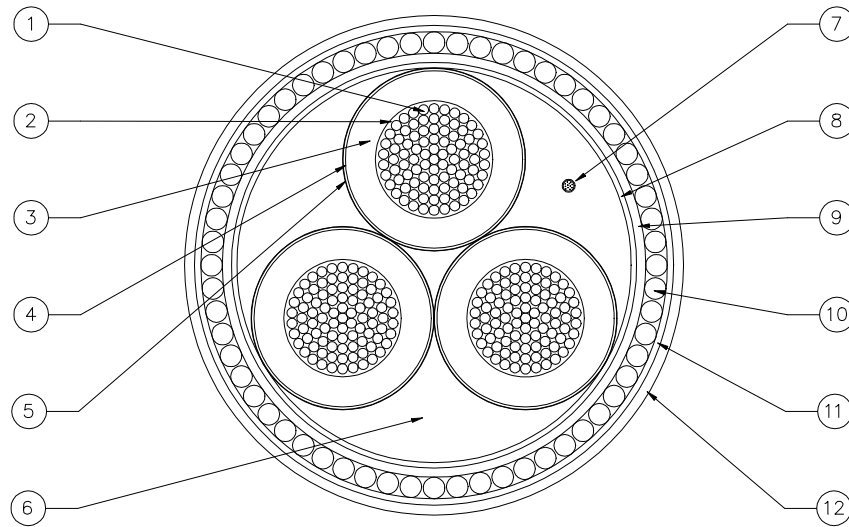
The two export cables for the North Hoyle wind farm are also 50Hz AC rated up to 36kV with three copper conductors but each cable has a cross-sectional area of 630mm<sup>2</sup>. These cables are also XPLE insulated and steel armoured.

The Burbo power export cables are buried to a nominal 3m depth in the beach sediments; however, actual depth is variable. The most westerly cable is buried to a consistent 4.5m depth across most of the beach, the burial depth of the central cable varies between 2.5 and 4m while the easterly cable lies at between 3 and 4.5m depth.

The cables at North Hoyle are believed to lie consistently at approximately 2m deep. There is, however, no recent depth of burial data available.







**Figure 19.** Typical cross-sectional representation of a wind farm power cable (not to scale). 1= conductor, 2= conductor screen, 3= insulation, 4= insulation screen, 5= core screen, 6= cores laid up with fillers, 7= fibre optic package, 8= binder tape, 9= armour bedding, 10= armour, 11= inner serving, 12= outer serving.

### 8.3. Methods

Details of the EMF production and measurement for the Ardtoe mesocosm study are given in Section 5.3.

Field surveys were carried out at Burbo Bank and North Hoyle wind farms in early February 2008. Initial trials of the equipment were made at Burbo (closest to Liverpool) and several visits were made in all. The results from the last visit to each site when equipment worked well and reliable data were obtained are reported here. The dates of survey cannot be reported as the wind farm operators provided generating statistics which are treated as commercially sensitive information.

Falling (Ebb) tides were selected on both dates for health and safety reasons relating to working in intertidal areas. Measurements were made in the shallow water around the tideline so the survey team had to follow the tide down the beach over a period of 2-3 hours.

The buried wind farm cables were located with a combination of GPS to locate known burial positions to within 1-5m, a magnetometer and real-time measurements of  $iE$  fields with a hand-held sensor. The hand-held sensor and magnetometer were first used to find the point of greatest field strength in water up to half a metre deep.

The hand held sensor had previously been used at North Hoyle to provide earlier measurements of  $B$  and  $iE$  fields from North Hoyle (CMACS and CIMS, unpublished work). The second electric field sensor formed part of a data logging unit which also contained a three axes magnetic field sensor (Figure 20). For brevity this combined  $E$  and  $B$  field unit is referred to as the pod and was the same set up used for the mesocosm study measurements.

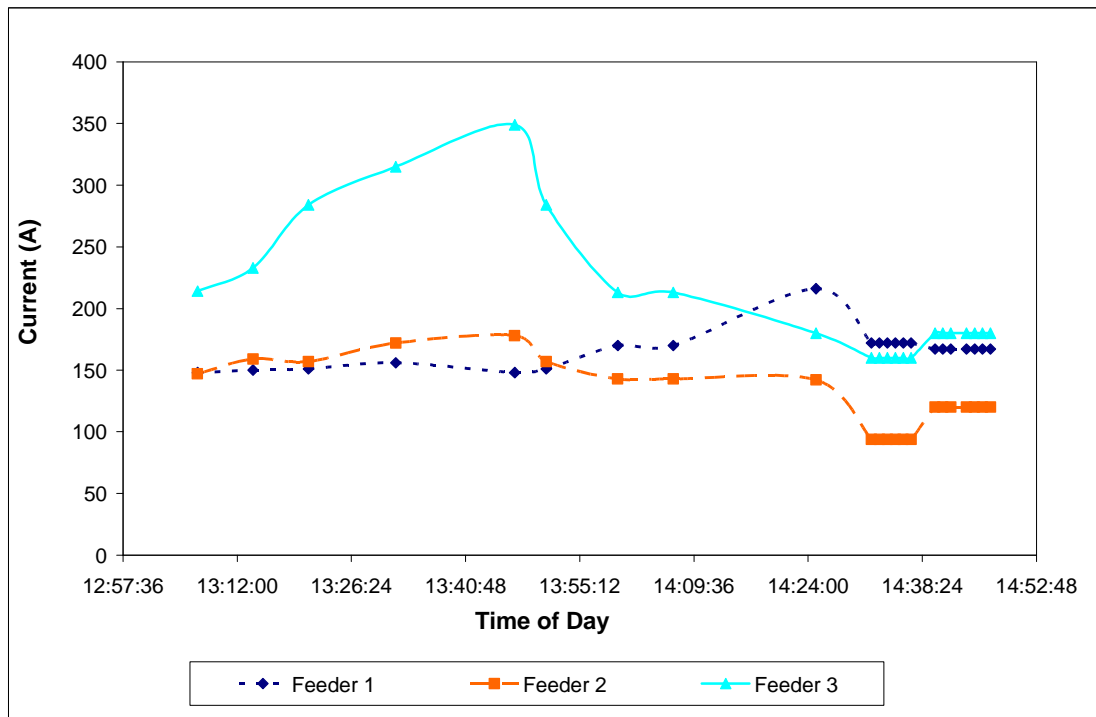
A key difference between the two units was that the later version had a more selective filter at 50Hz with a band pass of 40Hz and additional gain to increase its dynamic range. The first unit was smaller and more portable and was used extensively; the second was only deployed at selective positions at each location due to the time constraints imposed by the falling tides.



**Figure 20.** EMF Measurements at Rhyl (North Hoyle Wind Farm). The Hand-held iE field sensor is submerged in front of the surveyor's left foot and provided real-time data via a visual display. The pod (silver/white barrel) contained both B and iE field sensors and had logging capability but provided no live data. The two flags marked the position of the cable as detected by the hand held sensor and a magnetometer.

E and B field measurements were taken with the hand-held sensor and pod over the cable at the point of highest field strength and also at point up to 50 m from the cable to determine rate of decay and background fields, if present. A GPS was used to log a waypoint at each measurement point.

Current flows in each of the cables at the time of survey (i.e. wind farm generating statistics) were kindly provided by the wind farm operators (npower at North Hoyle and SeaScape Energy at Burbo). During the monitoring the current in the cables varied as wind farm production varied with the prevailing conditions (see Figure 21). This variation in current will have changed the magnetic field from the cable and, consequently, the B and iE Field readings taken on site. Data have therefore been normalised to 100A in order to make sensible comparisons and to permit direct comparisons with the results taken at Ardtoe. The actual fields measured are also reported.



**Figure 21.** Electrical current variation in feeder cables at Burbo (Feeder 1 is the most westerly cable).

## 8.4. EMF Measurements and comparison with Mesocosm Study

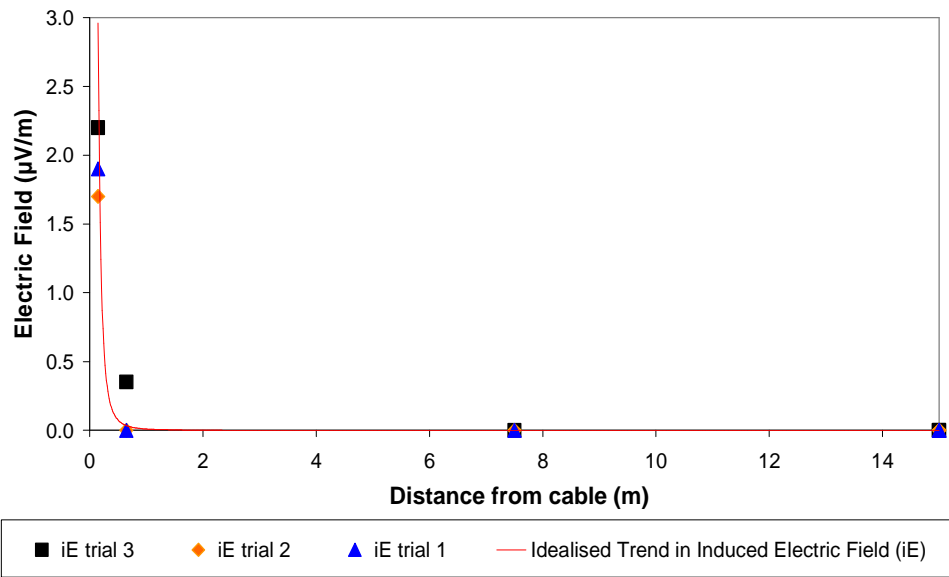
### 8.4.1. Ardtoe Mesocosm EMFs

The electrical generator current was set to 100A with the terminal line voltage at approximately 7 volts AC. The resulting electric and magnetic fields recorded at Ardtoe are shown in Figures 22 and 23.

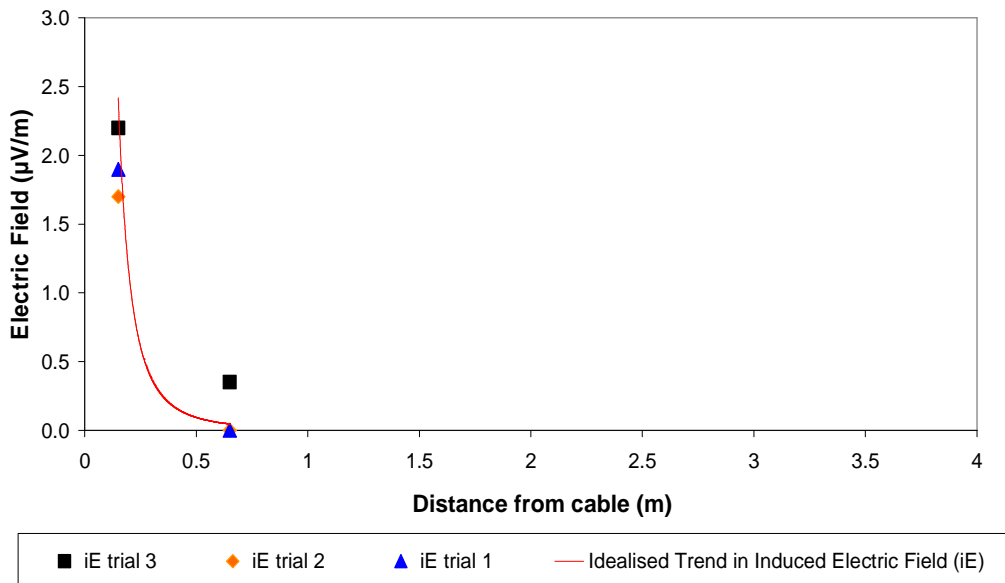
Figure 22a and b shows the results over a distance of 15 metres from the axis of the cable whilst Figure 23a and b shows the first 4 metres. Both sets of figures show the processed outputs from four monitoring locations in the mesocosm for three separate tests. The solid lines on each figure show the change in the ideal electric and magnetic fields moving radial away from the cable.

The scatter in points at 0.6 metres is considered to be due to the positioning of the sensor unit on the sea bed as the magnetic sensor was at one end of the sensor unit and therefore the location could have varied by up to 800mm with the value for the actual location dependent upon the orientation of the sensor unit.

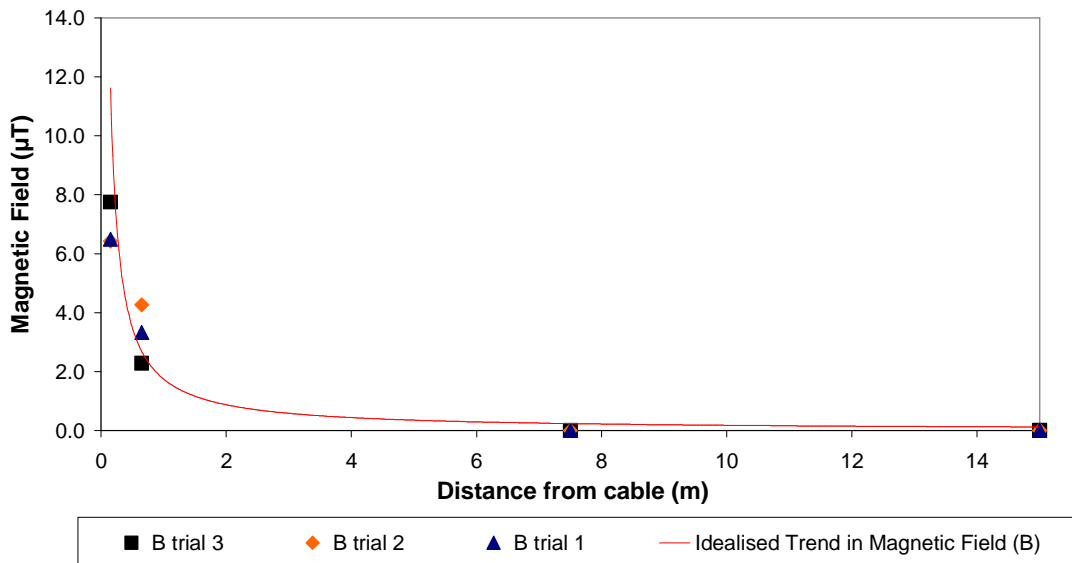
Note: another sensor pod was placed in the mesocosm where the cable was not energised. This sensor was used to check the background E and B fields. In all cases the unit did not record any E or B fields.



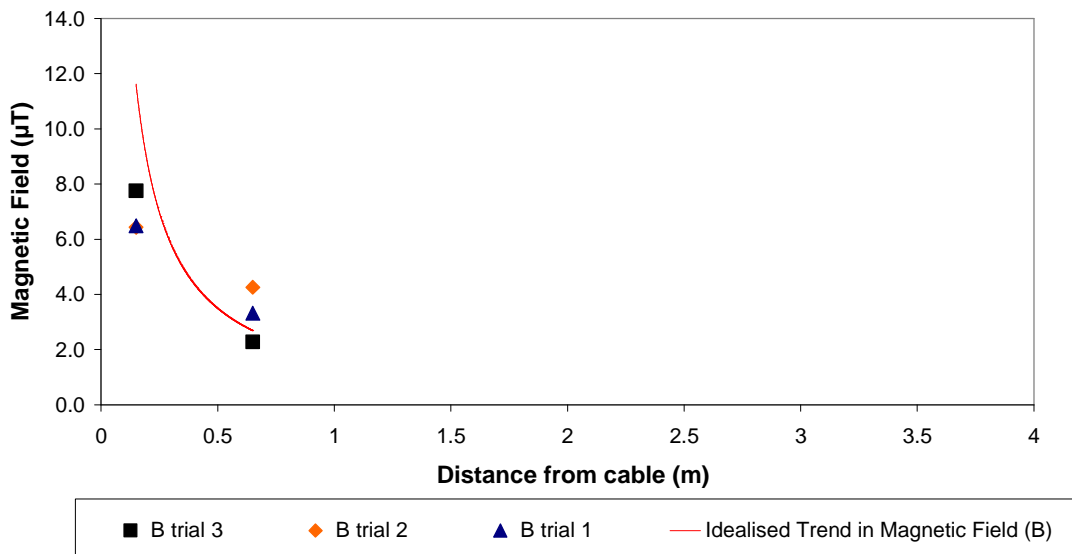
**Figure 22a.** Measured and predicted E field from cable to 15m away for the three Trials in Ardtoe Mesocosm study.



**Figure 22b.** Measured and predicted E field from cable to 4m away for the three Trials in Ardtoe Mesocosm study.



**Figure 23a.** Measured and predicted B field from cable to 15m away for the three Trials in Ardtoe Mesocosm study.



**Figure 23b.** Measured and predicted B field from cable to 4m away for the three Trials in Ardtoe Mesocosm study.

#### 8.4.2. Burbo Bank Wind Farm

The locations (numbered waypoints) of measurements at the Burbo Bank site are shown in Figure 24. The routes of the measurements are angled as a result of the survey team following the retreating tide down the shore.

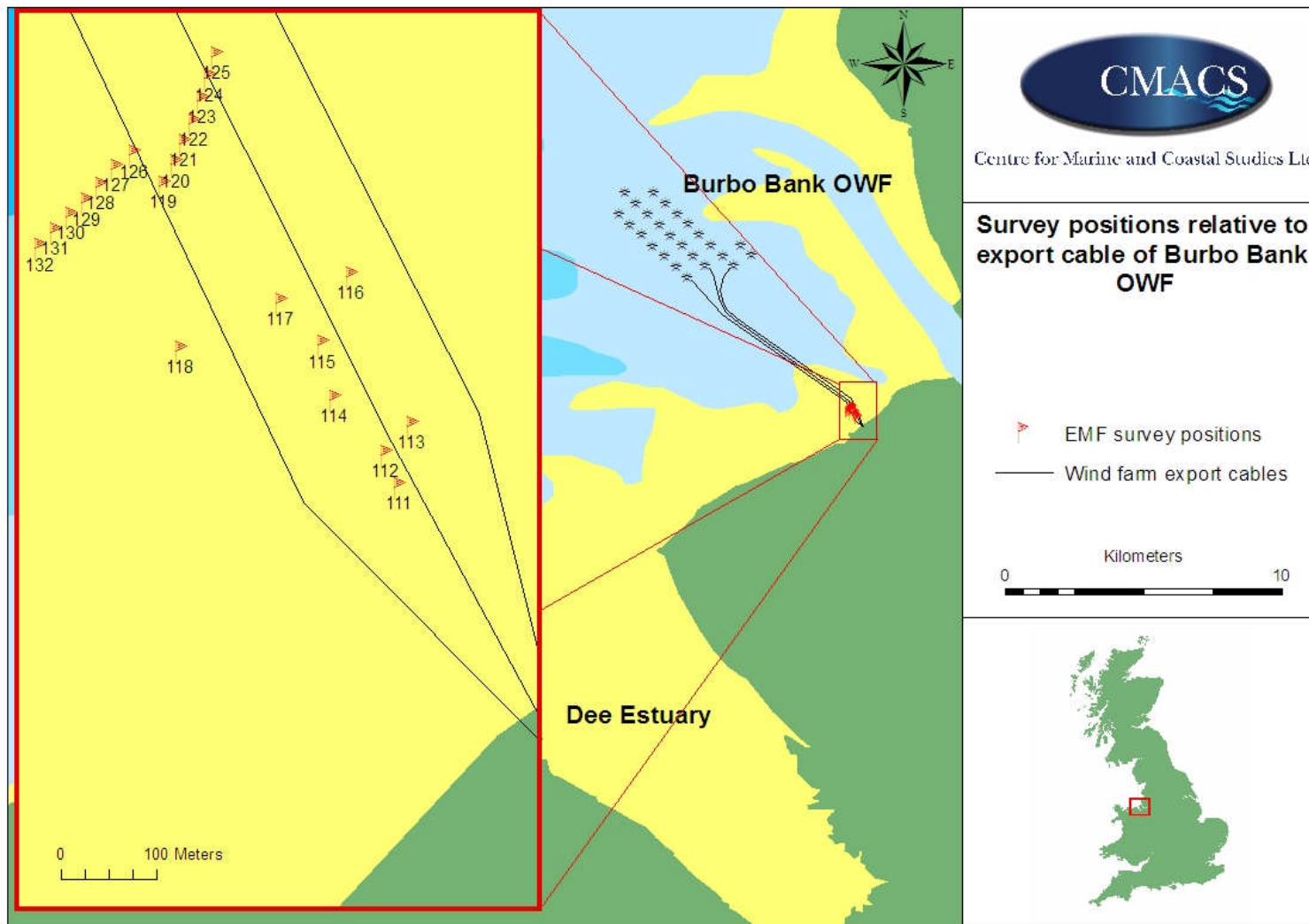
Owing to time constraints, the magnetic and electric fields were recorded with the pod only at locations 111 – 121. The hand held unit was used at all locations to monitor the electric fields along the cable (axial) and at right angles (normal) to the cable.

The field variation along the length of the middle cable (also called Feeder 2) is shown by waypoints 111, 112, 115 and 124 which lie close to the cable. The field variation across the most westerly cable (or Feeder 1) is represented by waypoints 127 – 132 and 119 – 123; this progression then crossed Feeder 2 further down the shore. Waypoint 126 was excluded since it lay slightly to the east of the cable while the other points were all immediately west.

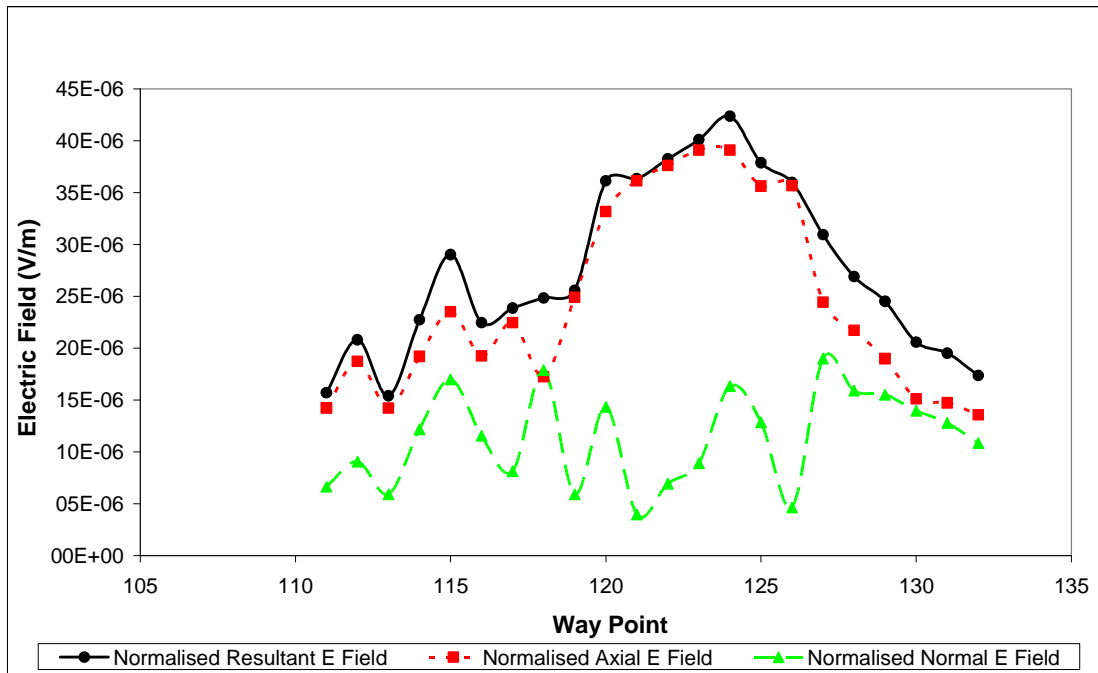
Figure 25 shows the normalised electrical fields detected by the hand held unit for all GPS way points. Three electric fields are shown; these are the axial, normal and resultant. The resultant electric field is the vector sum of the components. It is calculated by taking the square root of the sum of squared values of the axial and normal fields, i.e.:

$$\text{Resultant} = \sqrt{(\text{Axial}^2 + \text{Normal}^2)}$$

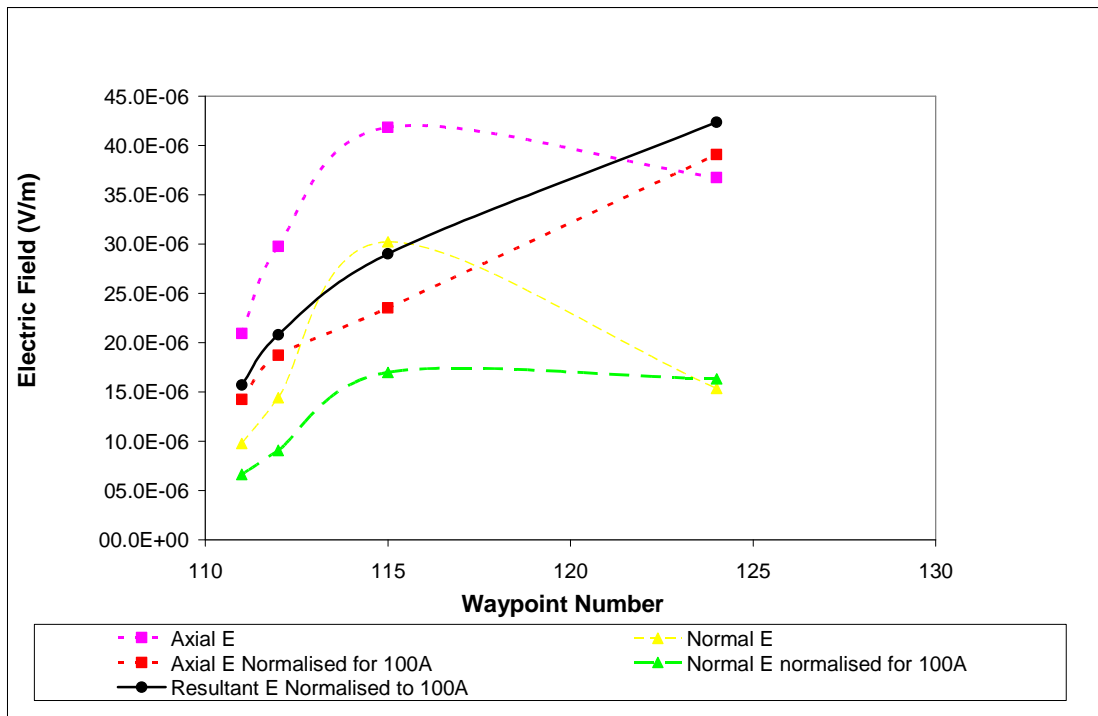
In this format the figure shows that the axial field is dominant whenever the measurement point is within the area bounded by the outer two cables. Outside this area (i.e. east and west of the cable route corridor) normal and axial fields are comparable.



**Figure 24.** Waypoint locations at Burbo Bank cable landfall. Cable (Feeder) 1 is the most westerly, 2 is central and 3 easterly.



**Figure 25.** Normalised electric field at all way points.



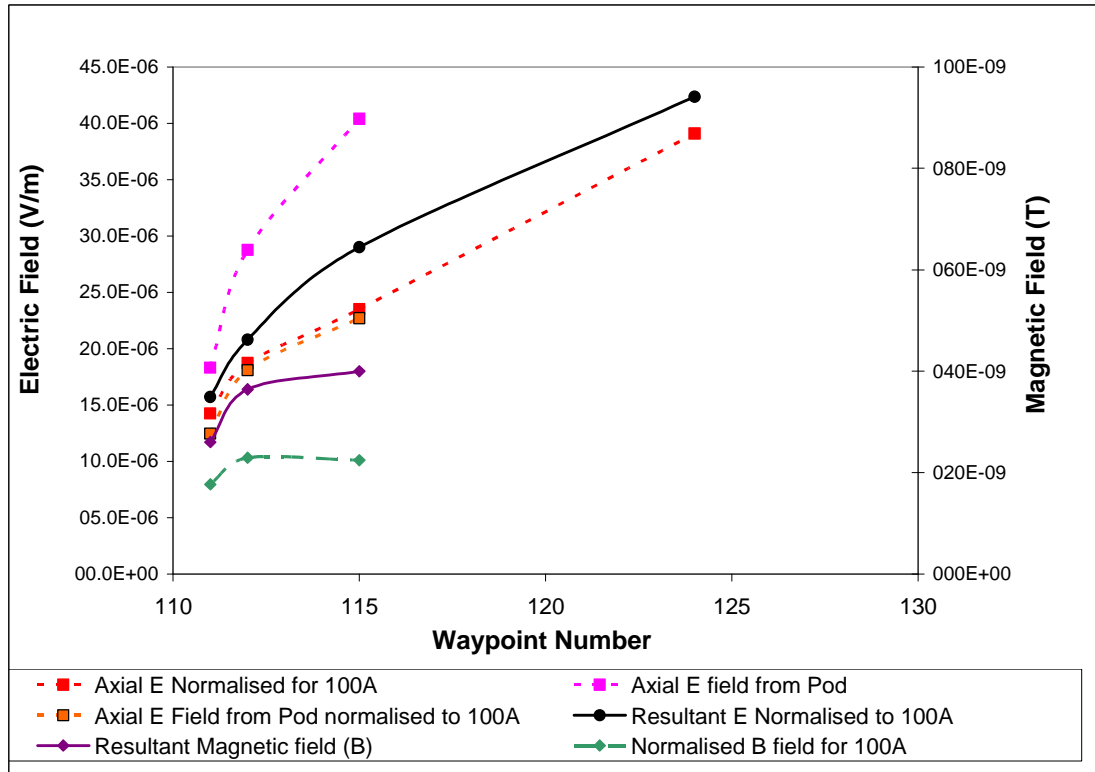
**Figure 26.** Electric Field variation along feeder 2 (actual and normalised fields). Resultant field is shown in brown.

EM Field variations along a 500m (approximately) length of Feeder 2 are shown in Figure 26. The non-normalised E fields give different profiles to the normalised values. The former show that the fields increase towards waypoint 115 and decrease thereafter, which is likely related to the fluctuating wind farm electricity generation and the burial depth of the cable. The normalised values show a continued increase from the shore towards the wind farm on



Feeder 2 and this likely relates to decreased burial depth in this area and/or lateral measurement error.

The largest field recorded was  $42\mu\text{V/m}$  (normalised to 100A). The axial E field was always larger than the normal field along the length of the feeder.



**Figure 27.** Electric and magnetic field variation along length of feeder 2 at Burbo Bank for handheld and pod units.

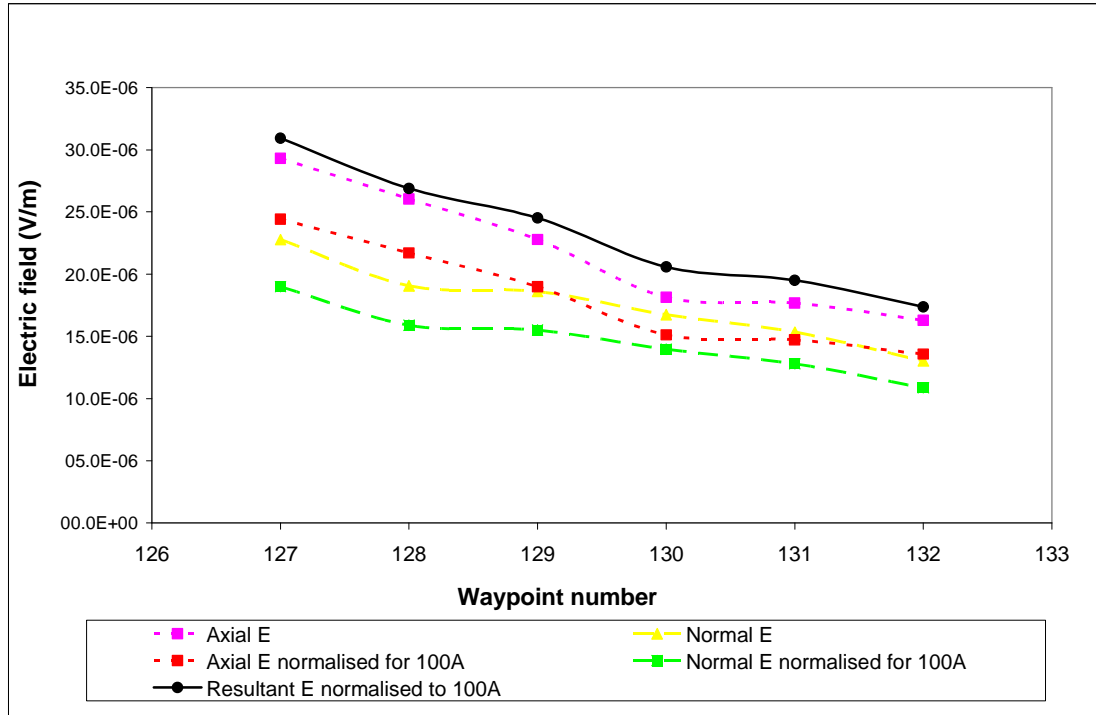
Figure 27 shows the normalised axial electric field from both the hand held and the pod units. The fields recorded by both units were similar to each other within the measurement error of the equipment. This is an important result as it demonstrates that the EM Fields at Ardtoe were comparable as we used the same pods for the measurements.

The magnetic fields are also shown. The normalised magnetic field was expected to be constant but the results show some variation which might be due to variation in the burial depth of the cable (the depth of burial of Feeder 2 is relatively variable, between 2.5 and 4m) or measurement error in the field.

Burial depth will have had an influence on the measurements taken as the B field varies with an inverse square relationship with distance from source. The maximum magnetic field recorded was  $0.6\mu\text{T}$  and when normalised to 100A was  $0.23\mu\text{T}$ .

Figure 28 shows the electric field moving radially away (west) from Feeder 1 (the westernmost cable). The electric field decreased as expected and the axial field was larger than the normal although the difference was less than compared to those values for Feeder 2. The measured electric field varied from approximately  $30\mu\text{V/m}$  close to the cable to around  $15\mu\text{V/m}$  approximately 150m to the west. This was a much slower rate of decay than anticipated (theoretically electric fields are expected to decay as  $1/\text{distance}^3$ ). The reason for the persistence of the electric field is not clear.

Whilst acknowledging that there is some uncertainty about the rate of decay in the E field, if we put these measurements into the context of the overall project the lowest known E field detectable by elasmobranchs is  $0.5 \mu\text{V/m}$ . For the Burbo feeder cable 1 the field perpendicular to the cable axis would drop below this level at approximately 295m away. It is not possible to calculate the E field to the east as the other two feeder cables are likely to influence the B and iE fields present.



**Figure 28.** Electric field variation moving away from the axis of cable feeder 1.

#### 8.4.3. North Hoyle Wind Farm

Figure 29 shows the position of measurement points (as numbered waypoints) in the intertidal area of the export cable landfall from North Hoyle Offshore Wind Farm. Here there are two cables rather than the three at New Brighton. Feeder 1 is the western cable, Feeder 2 the eastern. As at Burbo Bank Wind Farm, measurements were taken in the shallow water (<0.5m depth) by a team following the retreating tide.

The electric field values at all sample positions have been plotted in Figure 30. The fields were smaller than those recorded at Burbo Bank (Figure 25) but should not be compared directly before normalisation to 100A (see below). Also, the normal electric field was larger than the axial field, again opposite to the Burbo site although this difference did reduce further down the length of the cable (seawards). The reasons for this are uncertain although it is noted that the cable route is inclined to the shore line whereas at Burbo Bank the cable ran perpendicular to the shore; however, the significance of this fact is unclear.

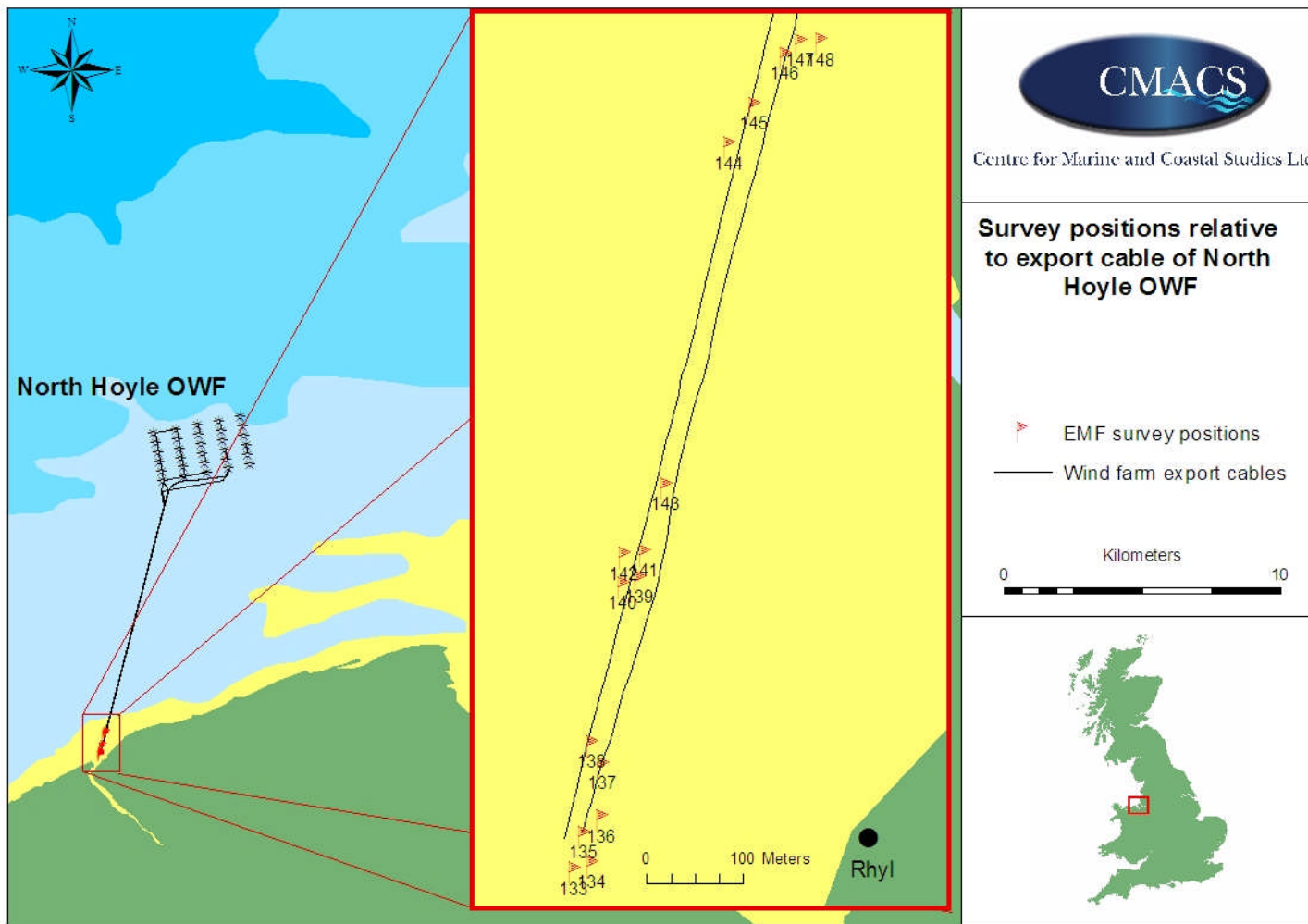
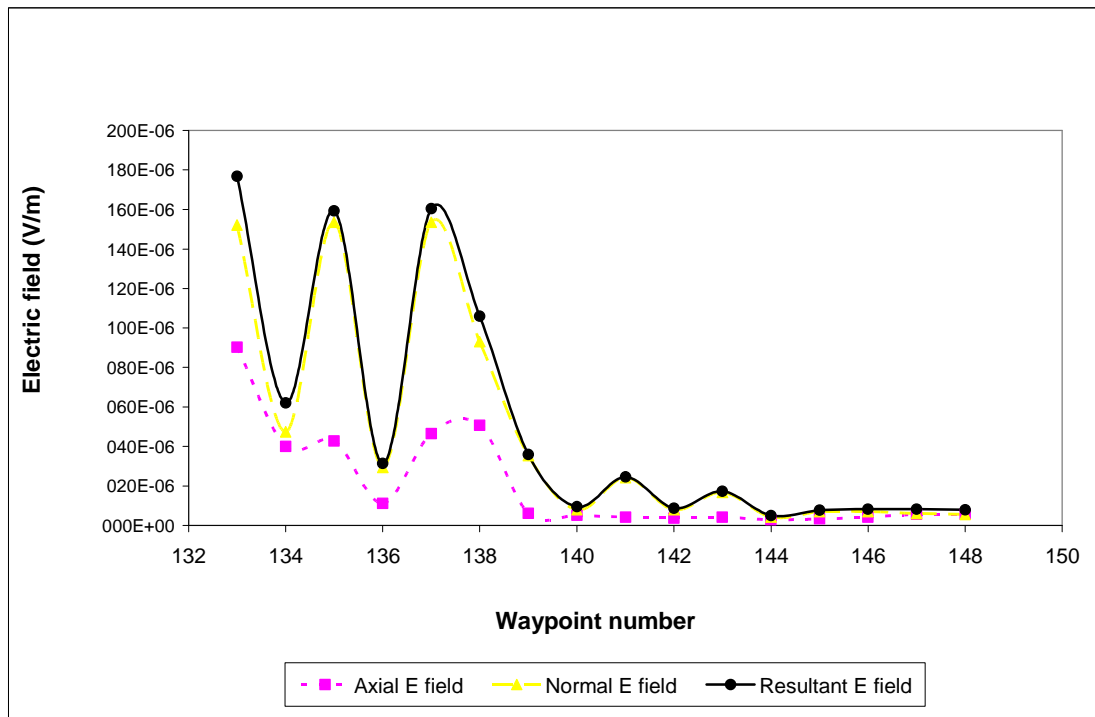


Figure 29. Waypoint locations for North Hoyle landfall. Feeder 1 is the western cable.

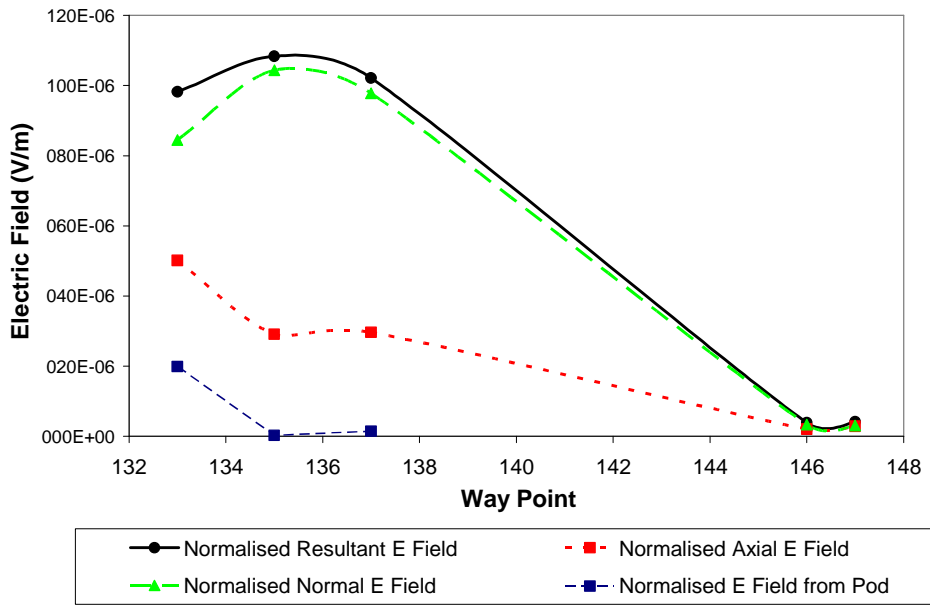


**Figure 30.** Electric field measurement for all waypoint positions at North Hoyle.

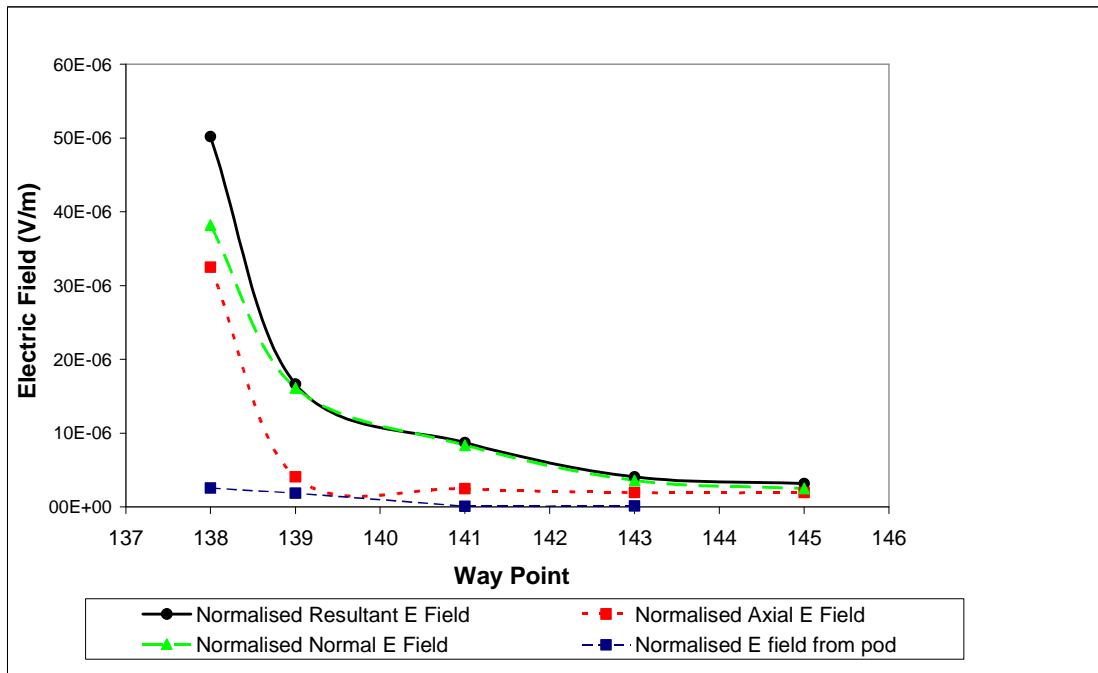
The maximum normalised electric field measured at North Hoyle was larger than at Burbo (maximum approximately  $110\mu\text{V/m}$  compared to  $42\mu\text{V/m}$  at Burbo). These values have been normalised for load currents of 100A to overcome fluctuations in wind farm generating status during the measurements.

Figures 31 and 32 show the electric field variation along the eastern and western cables at North Hoyle respectively. The field measured reduced with distance down the shore. The electric field reading from the pod was included in these figures although only a limited number of readings were taken. The recorded axial values for the hand held unit and the pod did not agree for the eastern cable, the pod values being lower than those from the hand held unit. The values for the western cable show better agreement except for way point 138. However, there is a greater error between the two sets of values than seen at Burbo. This might be due to the difference in site conditions where the electric field at North Hoyle showed large variations at the selected monitoring points and the difference in bandwidth between the two sensor systems might also have been a contributory factor.

It is unclear why the electric field reduced with distance down shore. This did not appear to be a simple consequence of wind farm generating status and cable burial depth on the beach at North Hoyle is believed to be relatively consistent at around 2m. Previous measurements of EM Fields at North Hoyle, both for early COWRIE projects and independent studies by CMACS and CIMS (unpublished) have recorded unusually high electrical fields have sometime been found in the Rhyl area that are believed to be unrelated to the wind farm, suggesting they were present before it was built.

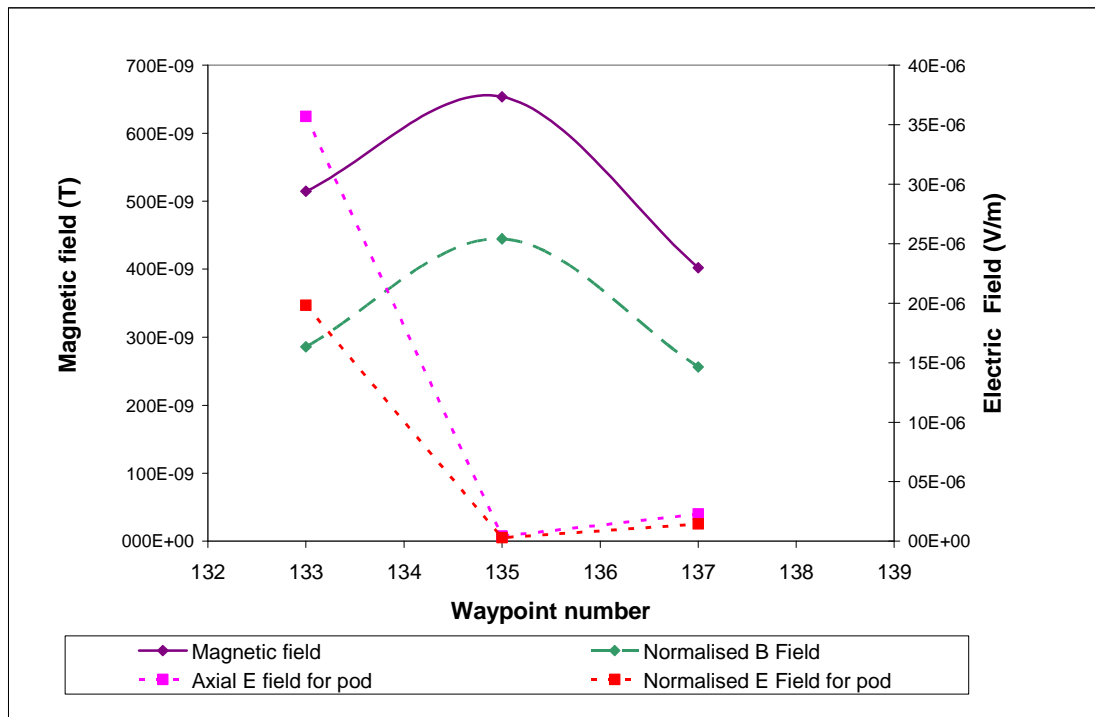


**Figure 31.** Electric field variation along eastern cable route.



**Figure 32.** Electric field variation along western cable route.

Figure 33 shows the magnetic and electric field from the pod unit. The magnetic and electric field values have been normalised to 100A. The magnetic field reached a maximum value of 6.5µT at way point 135. There appears to be no correlation between the electric and magnetic fields.



**Figure 33.** Magnetic and electric fields along eastern cable.

#### 8.4.4. A note on Cable Burial Depth

A clarification can be offered in relation to the importance of burial depth. It has previously been reported in COWRIE 1.0 and 1.5 reports using EMF modelling that cable burial is ineffective at mitigating against the potential effects of B and iE by reducing the magnitude of these fields sufficiently to be outside the range of detection by EMF sensitive species. The modelling assumed that the seabed sediments have very low conductivity compared to the seawater. Regardless of its magnitude, the magnetic field will be maximum at the cable and will decay with distance away from the cable (theoretically as  $1/\text{distance}^2$ ), both in the sediment and seawater (see COWRIE 1.0 EMF). Owing to the low conductivity of the sediment any induced E field diminishes rapidly in the sediment but is relatively high when the B field enters the conductive sea water-sediment surface interface. The magnitude of the induced electrical field also reduces in proportion to the B field. This scenario is complicated when we consider that sediments are often conductive owing to the presence of seawater within their particle structure. This means that the E field within the sediment may propagate further and then add to the induced E field at the sediment surface. The reason why this is important is that for some sediments the maximum induced E field emitted (ie. the in-sediment E field added to the sediment-sea water interface E field) by the sub-sea cable may be reduced through burial as the in-sediment E field will be attenuated.

It still remains true that there is no burial to depths practically achievable that will reduce the magnitude of the B field and hence the sediment-seawater interface, induced E field, below that at which they could be detected by certain marine organisms.

## 8.5. Conclusions

The cable set up, the depth of burial (to approximately 1m) and the magnetic and electric fields recorded at Ardtoe were comparable to the wind farms. The maximum B field in the mesocosm approached  $8\mu\text{T}$  which was associated with an iE field of approximately  $2.2\mu\text{V/m}$ . These EMF intensities were lower than we originally planned. This can be explained by the fact that there were small differences between the cable parameters used in the modelling and the characteristics of the cable that was actually used in the study. Furthermore, the realities of variability in where divers located the pod dataloggers with respect to the cable position within the sea bed would have lead to differences in the EMF measured. The differences were not large when we consider that we were dealing with very small E fields ( $\mu\text{V/m}$ ) and B fields ( $\mu\text{T}$ ).

The electric field detected at Ardtoe was directed along the axial length of the cable similar to Burbo Bank whilst at North Hoyle it was normal to the cable. This suggests that the electrical field environment at North Hoyle is potentially confounded with other EMF sources which have resulted in less comparability with the Ardtoe and Burbo data. The source of these E fields is not known, they may be due to return currents through the earth or other non identified sources of interference.

The comparison of electric fields recorded at Ardtoe and those at the wind farm sites is valid provided that the cables did not emit their own, direct electric field, which is based on the assumption that they were perfectly screened.

Based on the responses of the fish in the Ardtoe experiment and the level of EM-emission at the wind farm sites we would predict that EM-sensitive species predict that EM-sensitive species would encounter fields at or above the lower limit of their detection 295m from a cable. Hence there is potentially a large area that the species could respond within.

## 9. Project Conclusions

Overall, the COWRIE 2.0 EMF mesocosm study and wind farm surveys have provided evidence that the benthic, elasmobranch species studied can respond to the presence of EMF that is of the type and intensity associated with sub-sea cables. The response is not predictable and appears to be species specific and perhaps individual specific, meaning that some species and their individuals are more likely to respond by focussing movement within the zone of EMF. We found that when there was EMF emitted some Thornback Rays were more likely to move around within the EMF zone associated with the cable and a number of Catsharks were found nearer to the cable and they restricted their movement within the EMF area, which is consistent with species specific behavioural activity that is associated with feeding in these elasmobranchs.

Furthermore, the field measuring of EMF at offshore wind farms sites showed that there are both magnetic and electric field emissions associated with the main feeder cables to shore and these EMFs are comparable, and in some cases, greater than the EMF produced in the experimental mesocosm study. The zone of EMF that is potentially within the range of detection of the elasmobranchs spans several hundred metres.

The project has met its objective by demonstrating that some electrosensitive elasmobranchs will respond to the EMF emitted in terms of both the overall spatial distribution of one of the species tested and at the finer scale level of individual fish of different species.

Considering the novelty, the enormity of the logistics and the uniqueness of the project we are very satisfied that the experimental phase of the project has been completed successfully and addressed the main objective set out in the COWRIE 2.0 EMF project specification.



## 10. Recommendations

Whilst the mesocosm project demonstrated some responses by the elasmobranchs to the EMFs and the field survey provided evidence that the EMFs previously predicted to be emitted do exist there is a requirement to be objective in the assessment of the findings when considering recommendations that can be made.

There is no evidence from the present study to suggest any positive or negative effect on elasmobranchs of the EMF encountered. This was not an objective of the study and it can only be determined realistically through a combination of monitoring at offshore wind farm sites with appropriate analysis over time and further experimental based studies of specific behavioural responses that could indicate potential impacts (e.g. attraction/repulsion/barrier effects). Suggestions for monitoring programme were included in the COWRIE 1.5 EMF report ([http://www.offshorewindfarms.co.uk/Assets/1351\\_emf\\_phase\\_one\\_half\\_report.pdf](http://www.offshorewindfarms.co.uk/Assets/1351_emf_phase_one_half_report.pdf)).

Further experimental research would also reduce the time frame for understanding any effects by helping target species and life stages for monitoring. Targetted monitoring would be considerably cheaper than a catch-all comprehensive fishery survey to determine changes in numbers, demographics of populations and recruitment.

### *Experimental EMF Studies*

The mesocosm study used a limited number of species and also one EMF emission intensity which was towards the lower end of the range of detection for the elasmobranchs. Future work should focus on greater intensities and variability in EMF such as those measured at the wind farm sites. Such studies would provide the evidence base for further understanding of whether the responses of the fish are different at higher EMF intensities and if the boundary between attraction and avoidance for elasmobranchs (predicted to be approximately 100uV/m) is reached by OWF cable emissions.

Furthermore, there should be consideration of the potential response of other life stages (embryos and juveniles) to the EMFs present as they are likely to have different sensitivities and responses and they are often associated with the shallow, sandy environments that many of the wind farms are located within. By determining whether other life stages respond and to what degree will provide further evidence to target monitoring to specific species life stages.

### *Mesocosms*

In terms of the mesocosm study, the project has shown the utility of a large scale experimental approach for applying scientific rigour to environmental understanding of the interactions between offshore wind farms and the organisms that share the coastal environment.

The mesocosm site could be used for further studies and considering the logistics and expense of installing the facility it would be a good use of existing resources to reuse it.

The existing permissions and licences for the site of the mesocosms were due to end in February/March 2008. Following discussions within the project team, with Cefas and with Nature Bureau/COWRIE representatives it was seen as advantageous to seek extension to the permissions. The immediate benefit was that the mesocosms and associated structures would not need to be decommissioned as early as planned. Permitted extension would also provide the potential to reuse the mesocosm equipment for further relevant research using this unique set up.

Extensions to the site permissions and licences have now been obtained for:

- Section 34 consent
- FEPA licence
- Crown Estate

*EMF Emitted by Sub-sea cables*

There are two approaches suggested. The first is to build on the EMF sensor technology that has been developed through COWRIE projects to provide suitable equipment and protocol for determining the EMF emitted and its variability in relation to power production. A greater understanding of the variability spatially and over time is required to interpret whether the emissions are likely to be constant stimuli to the electrosensitive species inhabiting the environment around the wind farms.

The second approach is to undertake controlled studies of different cable configurations and specifications to more fully understand the characteristics and extent of the electromagnetic environment associated with offshore wind farm sub-sea cables individually and in multiple arrays.

## **11. Acknowledgements**

The project required the help and cooperation of many people. We would particularly like to thank the team at Viking Fish Farms Ltd for their timely assistance, technical support, general interest and good humour. Many thanks to John MacMillan for his field support and general technical knowledge, also the other boat operators, dive teams and fishermen in the local area who provided valuable support and services. Thanks to the manufacturers of the mesocosms, Fusion Marine, for taking on such a unique job and also the dive team from North West Marine Ltd for the installation of the mesocosms. Aggreko for their technical support. And finally the local community in Ardtoe for welcoming us and the project.

For the project analysis we are very grateful to Ben Clutterbuck and Adrian Yallop at Cranfield, Dave Righton at Cefas and Dale Webber, Vemco.

For the wind farm EMF study we would like to thank npower and Seascope Energy.

## 12. References

- Bart, J., Fligner, M.A. & Notz, W.I. 1998. *Sampling and Statistical Methods for Behavioural Ecologists*. Cambridge University Press.
- De Solla, S.R., Bonduriansky, R. & Brooks, R.J. 1999. Eliminating autocorrelation reduces biological relevance of home range estimatesKS
- Dytham, C. 2003. *Choosing and Using Statistics*. 2<sup>nd</sup> Edition. Blackwell Publishing.
- Griffith, D.A. 1992. What is spatial autocorrelation? Reflections on the past 14 years of spatial statistics. *L'Esplanade géographique*, 3, 265-280.
- Gill, A.B. (2005). Offshore renewable energy - ecological implications of generating electricity in the coastal zone. *Journal of Applied Ecology* 42: 605-615.
- Gill, A.B., Gloyne-Phillips, I., Neal, K.J. & Kimber, J.A. (2005). The potential effects of electromagnetic fields generated by sub-sea power cables associated with offshore wind farm developments on electrically and magnetically sensitive marine organisms – a review. Report to Collaborative Offshore Wind Research into the Environment (COWRIE) group, Crown Estates.
- Hooge, P.N. & Eichenlaub, B. 2000. Animal Movement Extension to ArcView version 2.0. Alaska Science Center, Biological Science Office, US Geological Survey, Anchorage, USA.
- Hooge, P.N., Eichenlaub, W.M. & Solomon, E.K. 2000. Using GIS to analyze animal movements in the marine environment. In *Spatial Processes and Management of Marine Populations*, (eds. G.H. Kruse, N. Bez, A. Booth, M.W. Dorn, S. Hills, R.N. Lipcius, D. Pelletier, C. Roy, S.J. Smith, & D. Witherell), pp. 37-51. 17th Lowell Wakefield Fisheries Symposium.
- Jones, K.M.M. 2005. Home range areas and activity centres in six species of Caribbean wrasses (Labridae). *Journal of Fish Biology*, 66, 150-166.
- Kalmijn, A.J. 1971. The electric sense of sharks and rays. *Journal of Experimental Biology*, 55(2), 371-383.
- Ohman, M.C., P. Sigraý & H. Westerberg (2007). Offshore windmills and the effects of Electromagnetic Fields on fish. *Ambio* 36(8), 630-633.
- Poléo, A.B.S., H. F. Johannessen & M. Harboe jr. (2001). High voltage direct current (HVDC) sea cables and sea electrodes: effects on marine life. Department of Biology, University of Oslo, P.O.Box 1066 Blindern, N-0316 Oslo, Norway.
- Righton, D. and Mills, C. (2006) 'Application of GIS to investigate the use of space in coral reef fish: a comparison of territorial behaviour in two Red Sea butterflyfishes', *International Journal of Geographical Information Science*, 20:2, 215-232.
- Seaman, D.E. & Powell, R.A. 1996. An evaluation of the accuracy of kernel density estimators for home range analysis. *Ecology*, 77, 2075-2085.
- Schoener, T.W. 1981. An empirically based estimate of home range. *Theoretical Population Biology*, 20, 281-325.
- Swihart, R.K. & Slade, N.A. 1985. Testing for independence of observations in animal movements. *Ecology*, 66, 1176-1184.
- Worton, B.J. 1987. A review of models of home range for animal movement. *Ecological Modelling*, 38, 277-298.

## **13. Appendices**

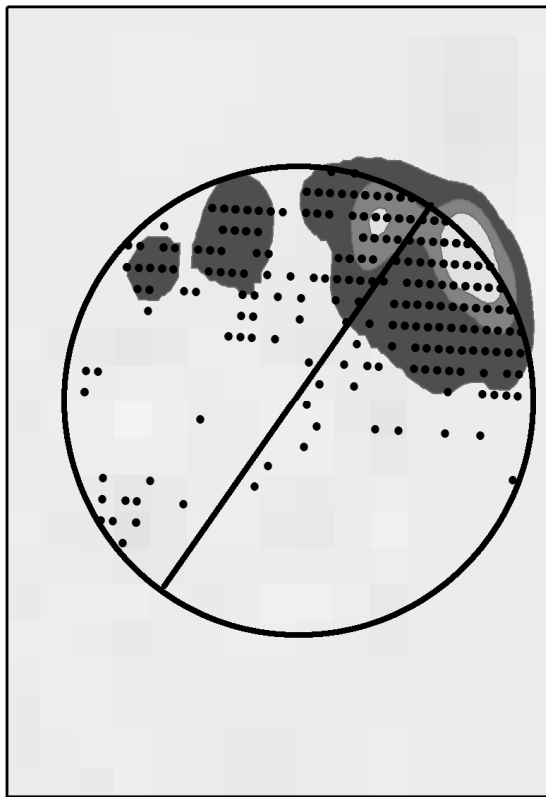
1. Kernel Density Probability Functions (KDPF) for all acoustic tracking data. See main text for details.
2. Plots of Data Storage Tag (DST) data showing depth related response of a sub set of fish individuals.
3. Current and temperature data for the Ardtoe mesocosm site during November and December 2007.

**Trial 3**  
**Overview of spatial distribution in 'Live' Mesocosm**

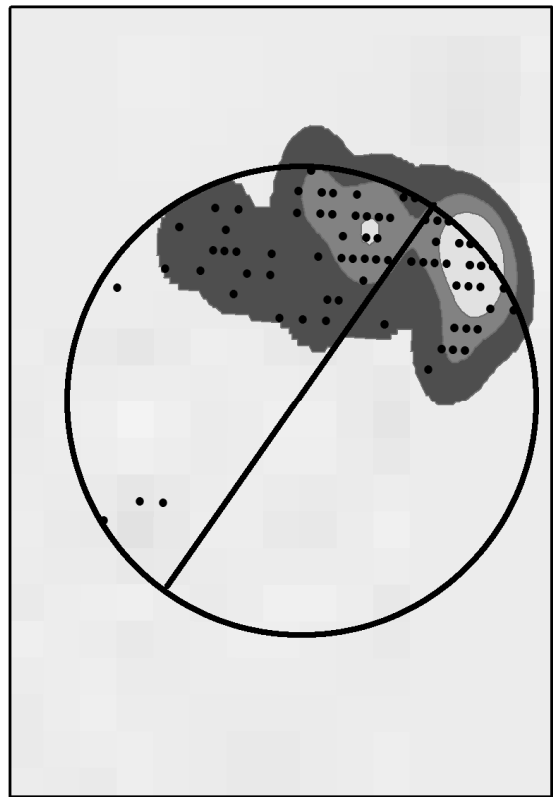
Study species:- Dogfish (*S.canicula*)

Study period:- Daylight looking at total of 13 events (cable switch on's)  
(Event No's:- 1, 3, 5, 7, 13, 15,19, 21, 23, 27, 29, 31, 33)

Dogfish during day with cable off  
(all revised data)



Dogfish during day with cable on  
(all revised data)



KPDF shading shows the probability density surfaces for 95% (dark grey), 75% (mid grey) and 50% (white)

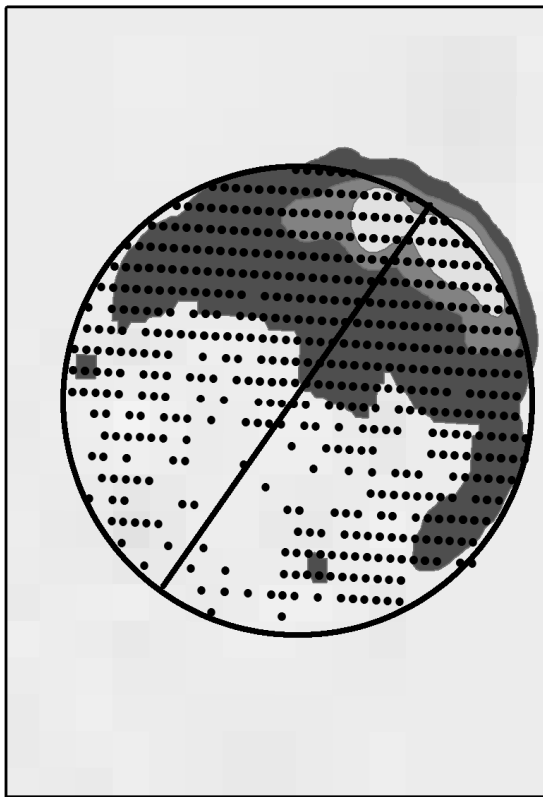
**Trial 3**  
**Overview of spatial distribution in 'Live' Mesocosm**

Study species:- Dogfish (*S.canicula*)

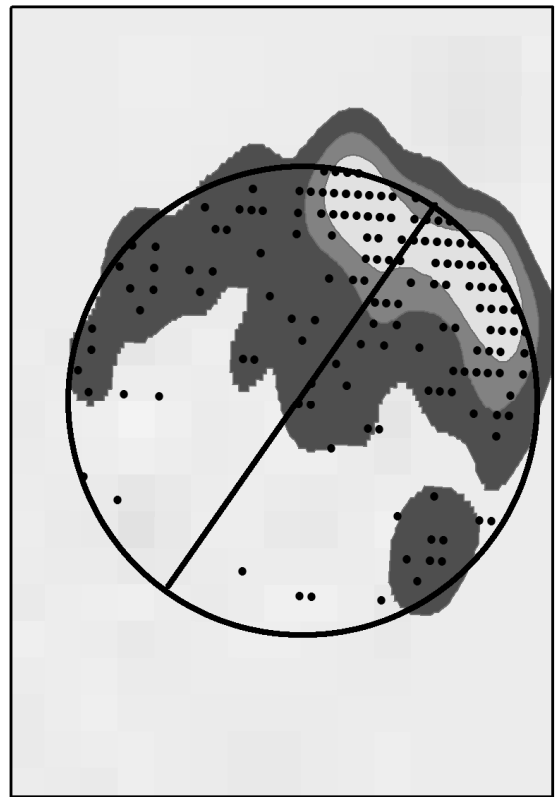
Study period:- Night time looking at total of 14 events (cable switch on's)

(Event No's:- 2, 4, 6, 12, 14, 16, 18, 20, 22, 24, 28, 30, 32, 34)

Dogfish during night with cable off  
(all revised data)



Dogfish during night with cable on  
(all revised data)



KPDF shading shows the probability density surfaces for 95% (dark grey), 75% (mid grey) and 50% (white)

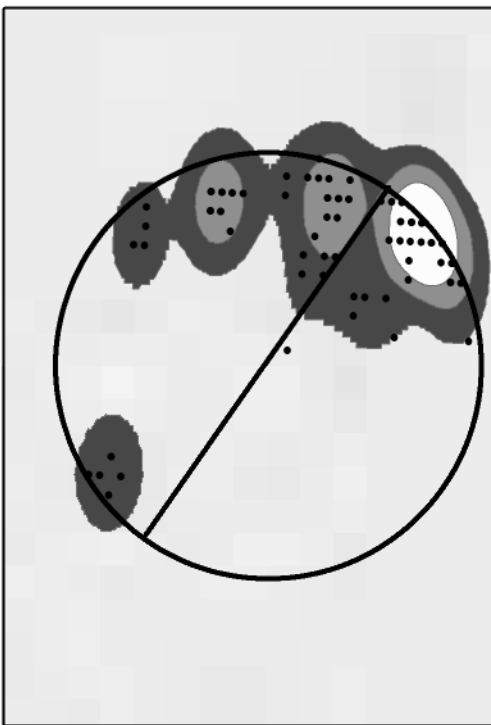
**Trial 3**  
**Detailed spatial distribution in 'Live' Mesocosm**  
**(1hr before, during and after cable switch on's)**

Study species:- Dogfish (*S.canicula*)

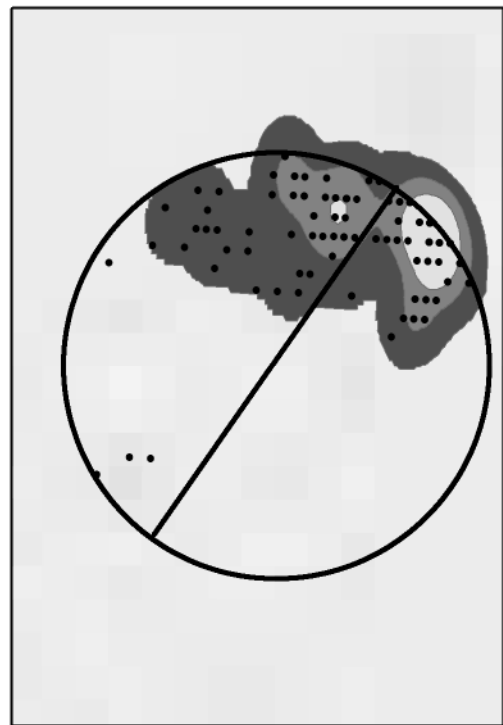
Study period:- Daylight looking at total of 13 events (cable switch on's)

(Event No's:- 1, 3, 5, 7, 13, 15,19, 21, 23, 27, 29, 31, 33)

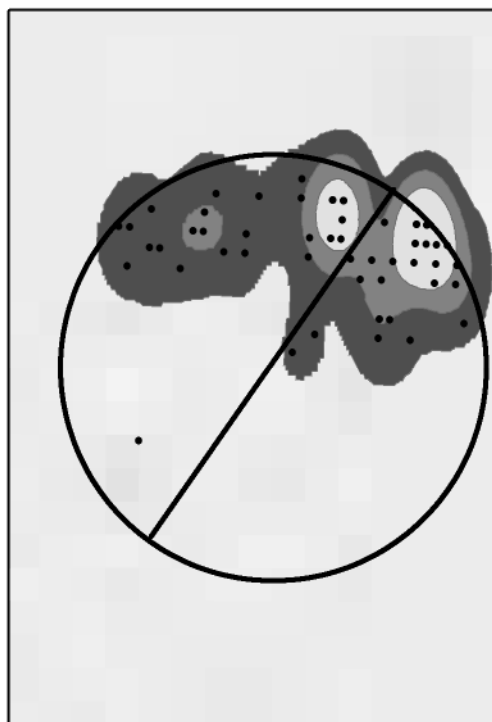
Dogfish  
Day 1hr before cable on's  
(all revised data)



Dogfish  
During 1hr cable on's  
(all revised data)



Dogfish  
1hr after cable on's  
(all revised data)





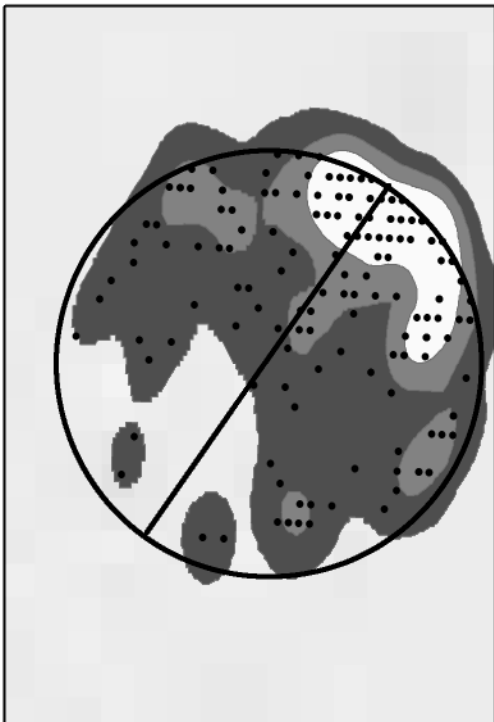
**Trial 3**  
**Detailed spatial distribution in 'Live' Mesocosm**  
**(1hr before, during and after cable switch on's)**

Study species:- Dogfish (*S.canicula*)

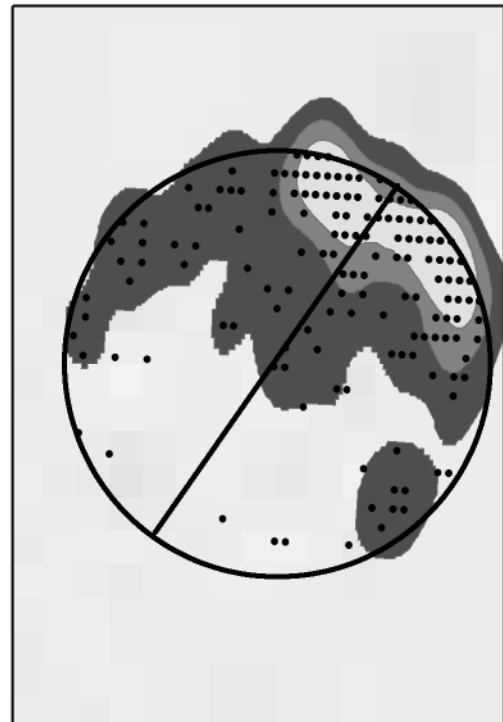
Study period:- Night time looking at total of 14 events (cable switch on's)

(Event No's:- 2, 4, 6, 12, 14, 16, 18, 20, 22, 24, 28, 30, 32, 34)

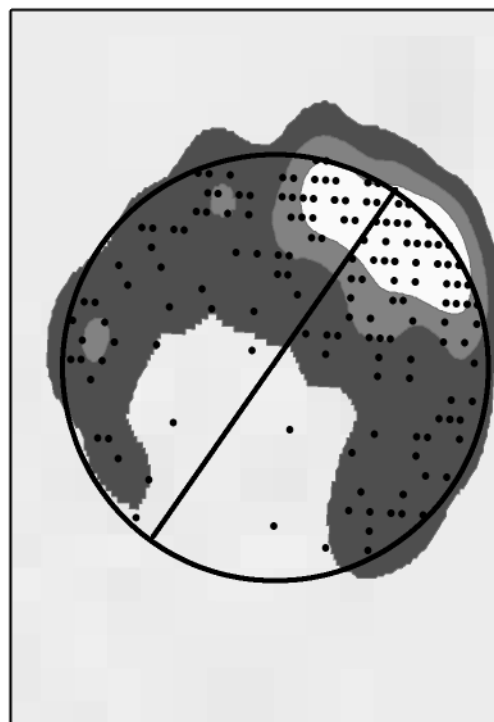
Dogfish  
Night 1hr before cable on's  
(all revised data)



Dogfish  
During 1hr cable on's  
(all revised data)



Dogfish  
1hr after cable on's  
(all revised data)



**Trial 3**  
**Overview of spatial distribution in 'Control' Mesocosm**

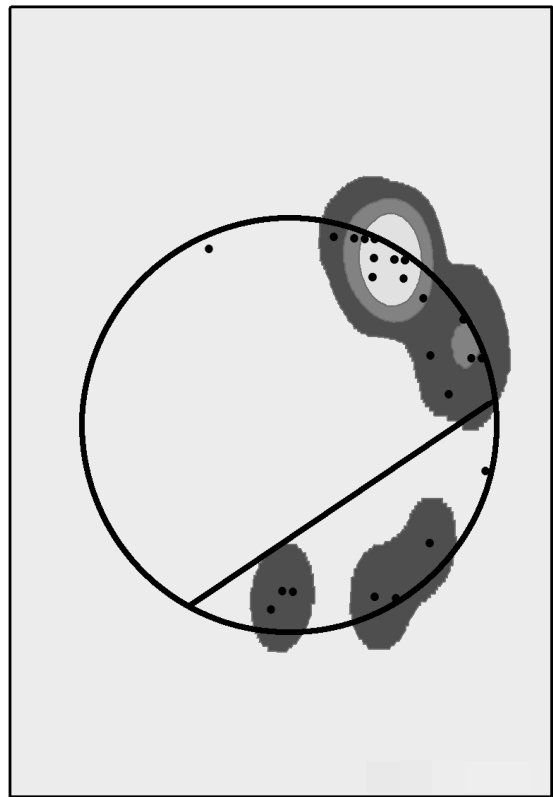
Study species:- Dogfish (*S.canicula*)

Study period:- Daylight looking at total of 13 events (cable switch on's)  
(Event No's:- 1, 3, 5, 7, 13, 15,19, 21, 23, 27, 29, 31, 33)

Dogfish during day with cable off  
(all revised data)



Dogfish during day with cable on  
(all revised data)



KPDF shading shows the probability density surfaces for 95% (dark grey), 75% (mid grey) and 50% (white)

**Trial 3**  
**Overview of spatial distribution in 'Control' Mesocosm**

Study species:- Dogfish (*S.canicula*)

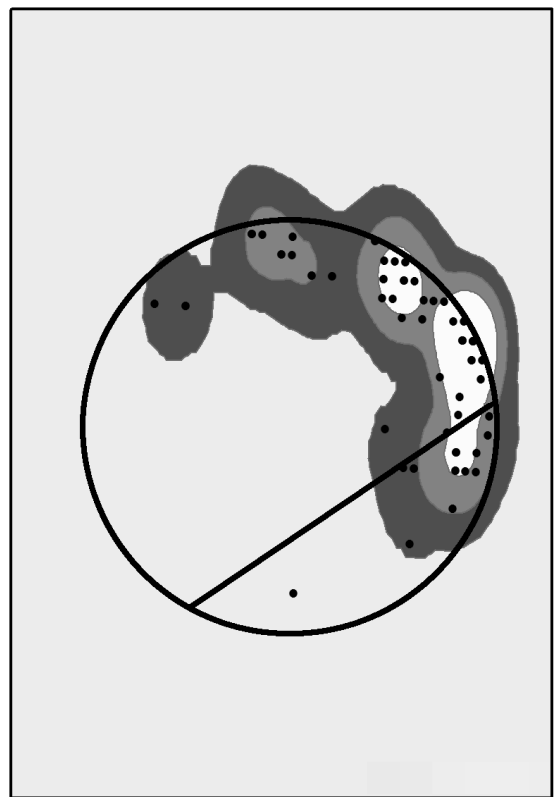
Study period:- Night time looking at total of 14 events (cable switch on's)

(Event No's:- 2, 4, 6, 12, 14, 16, 18, 20, 22, 24, 28, 30, 32, 34)

Dogfish during night with cable off  
(all revised data)



Dogfish during night with cable on  
(all revised data)



KPDF shading shows the probability density surfaces for 95% (dark grey), 75% (mid grey) and 50% (white)

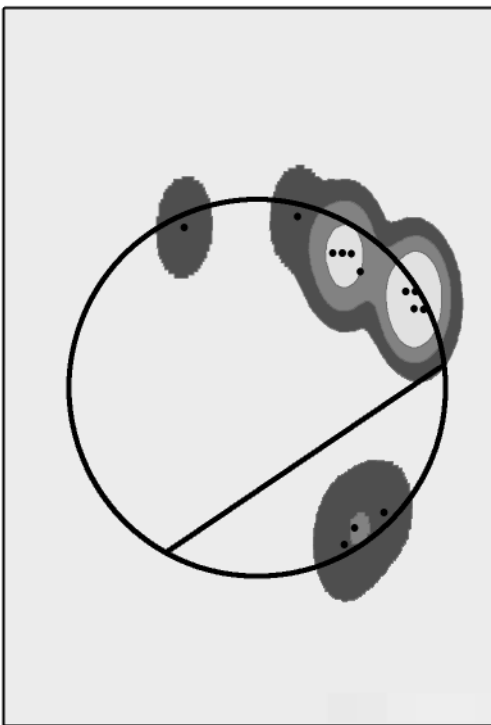
**Trial 3**  
**Detailed spatial distribution in 'Control' Mesocosm**  
**(1hr before, during and after cable switch on's)**

Study species:- Dogfish (*S.canicula*)

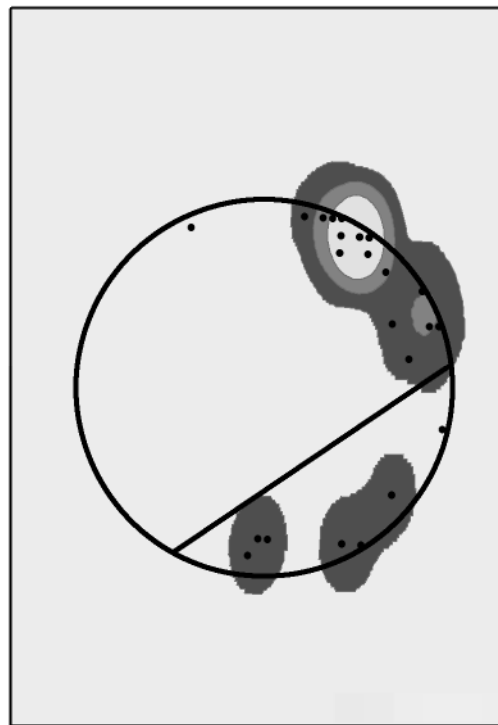
Study period:- Daylight looking at total of 13 events (cable switch on's)

(Event No's:- 1, 3, 5, 7, 13, 15,19, 21, 23, 27, 29, 31, 33)

Dogfish  
Day 1hr before cable on's  
(all revised data)



Dogfish  
During 1hr cable on's  
(all revised data)



Dogfish  
1hr after cable on's  
(all revised data)

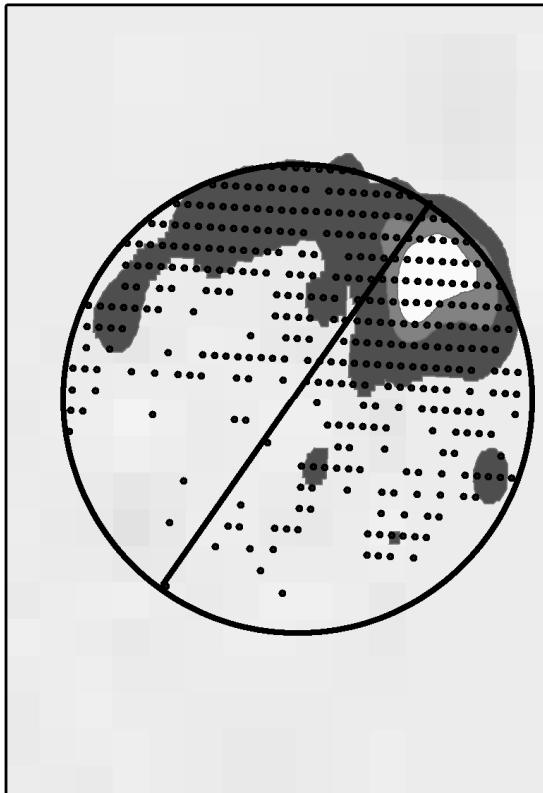


**Trial 1**  
**Overview of spatial distribution in 'Live' Mesocosm**

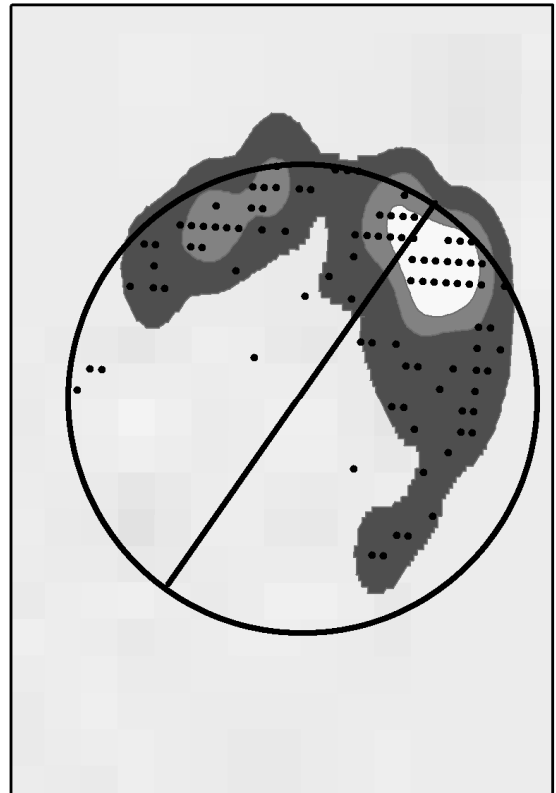
Study species:- Ray (*R.clavata*)

Study period:- Daylight looking at total of 11 events (cable switch on's)  
(Event No's:- 38, 40, 42, 44, 46, 48, 50, 52, 54, 60, 62)

Rays during day with cable off  
(all revised data)



Rays during day with cable on  
(all revised data)



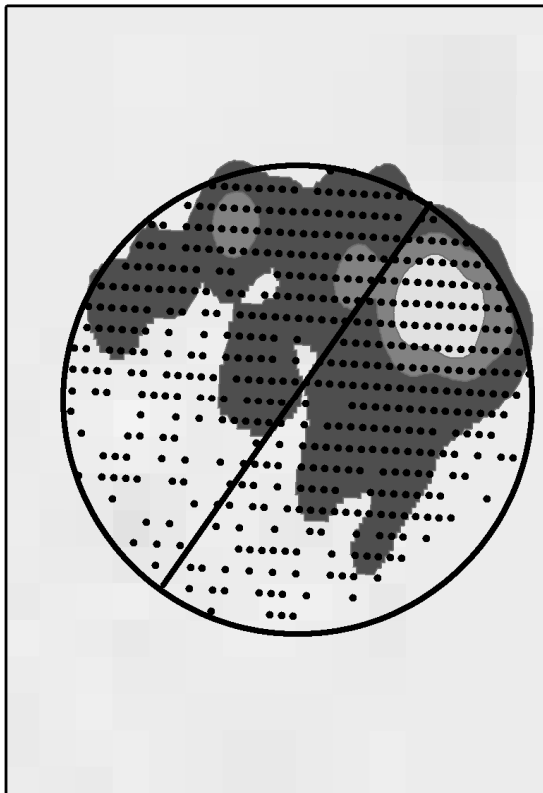
KPDF shading shows the probability density surfaces for 95% (dark grey), 75% (mid grey) and 50% (white)

**Trial 1**  
**Overview of spatial distribution in 'Live' Mesocosm**

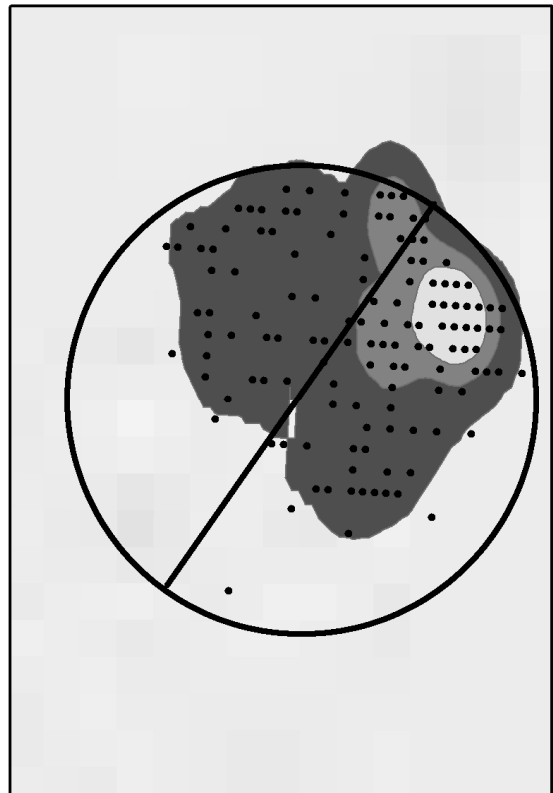
Study species:- Ray (*R. clavata*)

Study period:- Night time looking at total of 10 events (cable switch on's)  
(Event No's:- 39, 41, 43, 45, 47, 49, 51, 53, 61, 63)

Rays  
during night with cable off  
(all revised data)



Rays  
during night with cable on  
(all revised data)



KPDF shading shows the probability density surfaces for 95% (dark grey), 75% (mid grey) and 50% (white)

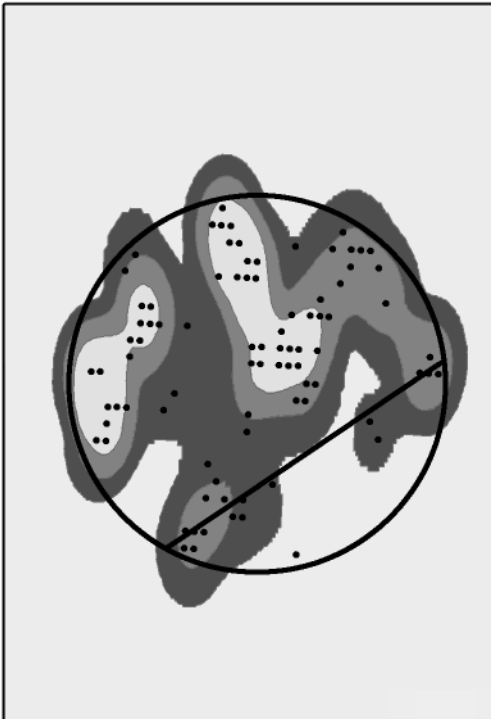
**Trial 1**  
**Detailed spatial distribution in 'Live' Mesocosm**  
**(1hr before, during and after cable switch on's)**

Study species:- Ray (*R.clavata*)

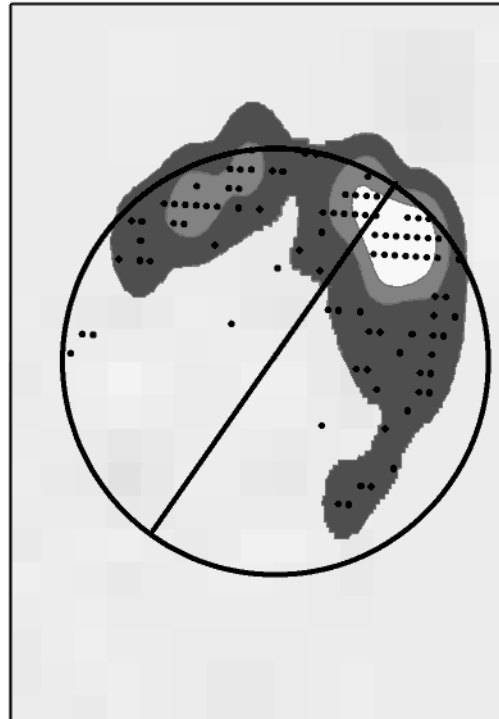
Study period:- Daylight looking at total of 11 events (cable switch on's)

(Event No's:- 38, 40, 42, 44, 46, 48, 50, 52, 54, 60, 62)

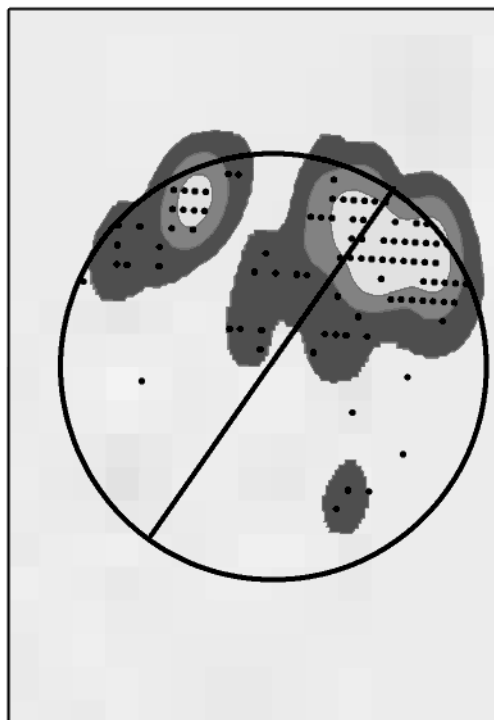
Rays  
Day 1hr before cable on's  
(all revised data)



Rays  
During 1hr cable on's  
(all revised data)



Rays  
1hr after cable on's  
(all revised data)



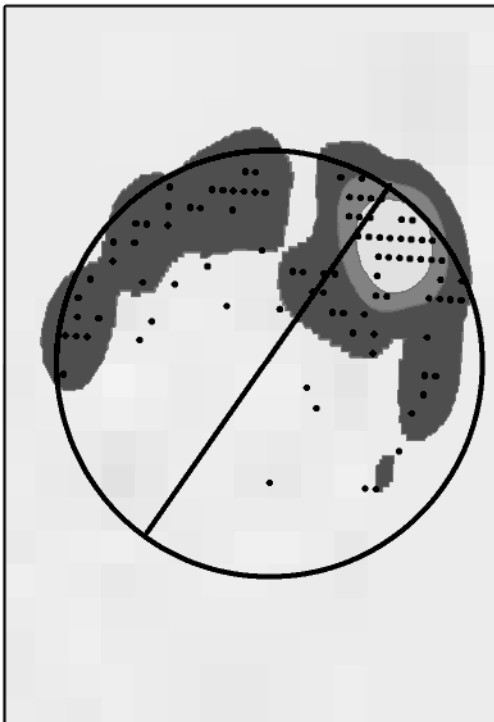
**Trial 1**  
**Detailed spatial distribution in 'Live' Mesocosm**  
**(1hr before, during and after cable switch on's)**

Study species:- Ray (*R.clavata*)

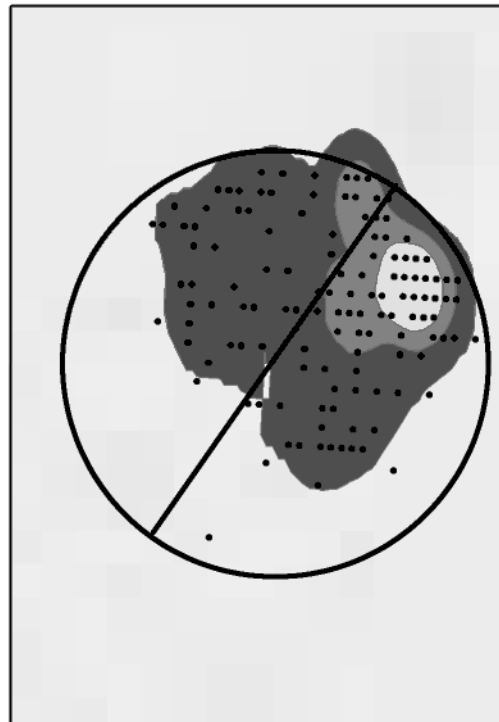
Study period:- Night time looking at total of 10 events (cable switch on's)

(Event No's:- 39, 41, 43, 45, 47, 49, 51, 53, 61, 63)

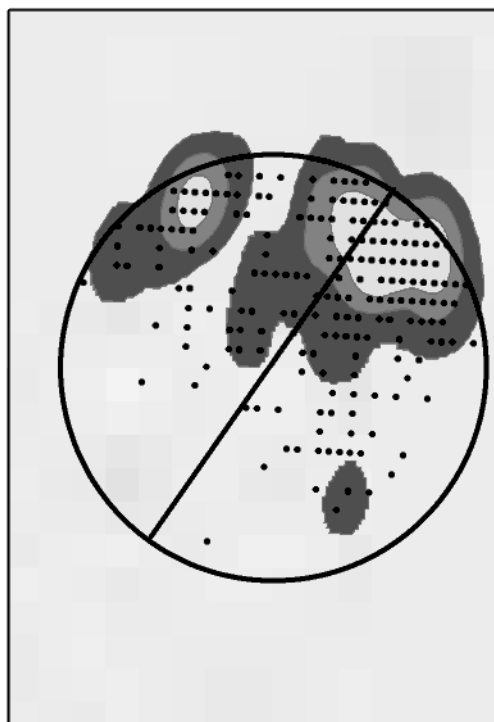
Rays  
Night 1hr before cable on's  
(all revised data)



Rays  
During 1hr cable on's  
(all revised data)



Rays  
1hr after cable on's  
(all revised data)



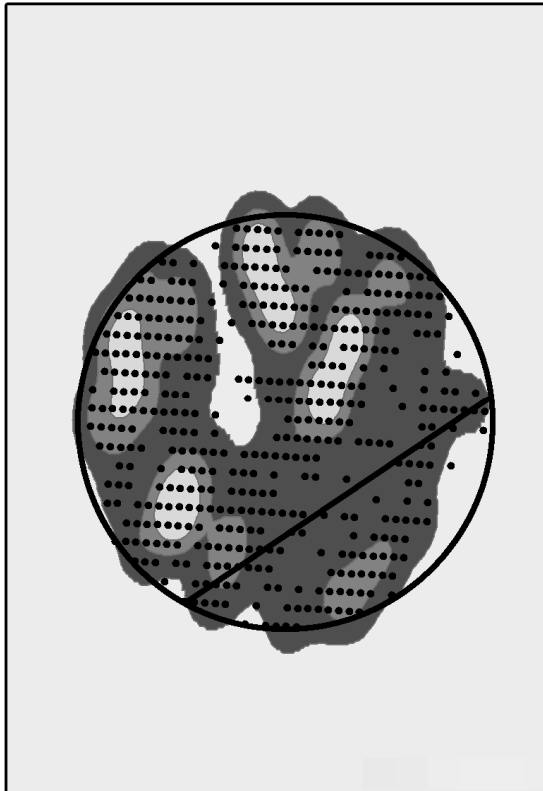


**Trial 1**  
**Overview of spatial distribution in Control Mesocosm**

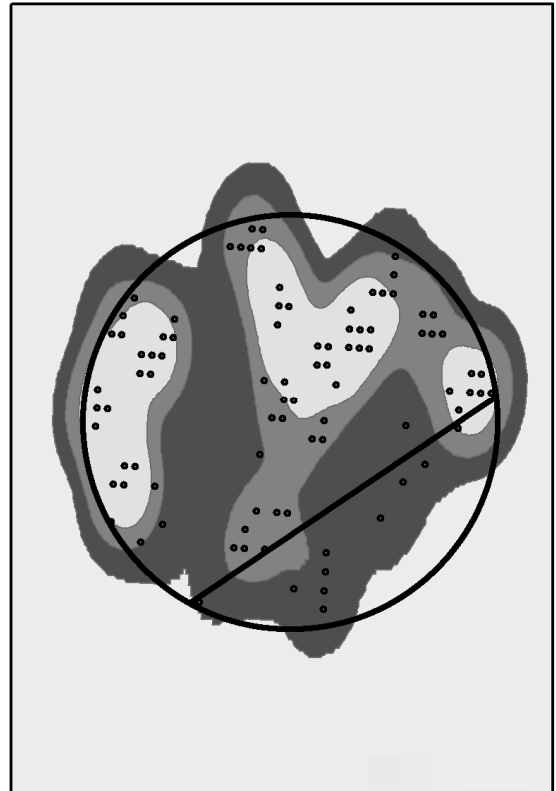
Study species:- Ray (*R.clavata*)

Study period:- Daylight looking at total of 11 events (cable switch on's)  
(Event No's:- 38, 40, 42, 44, 46, 48, 50, 52, 54, 60, 62)

Ray during day with cable off  
(all revised data)



Ray during day when cable on  
(all revised data)



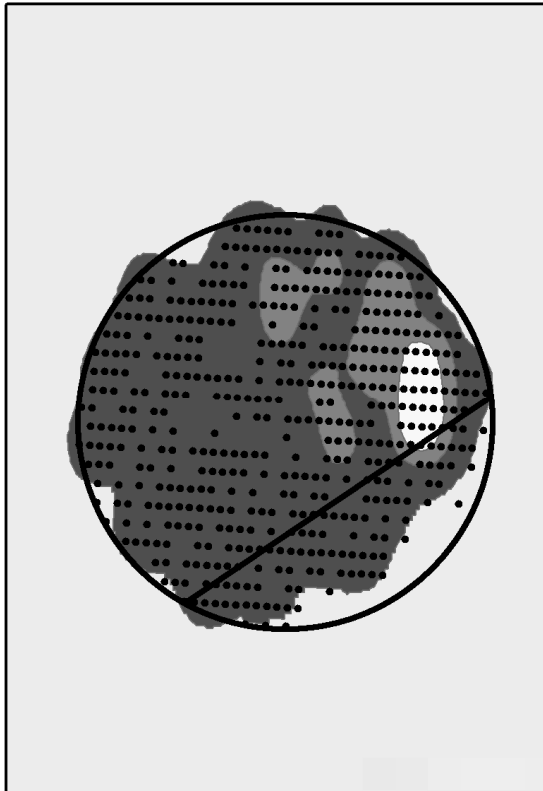
KPDF shading shows the probability density surfaces for 95% (dark grey), 75% (mid grey) and 50% (white)

**Trial 1**  
**Overview of spatial distribution in Control Mesocosm**

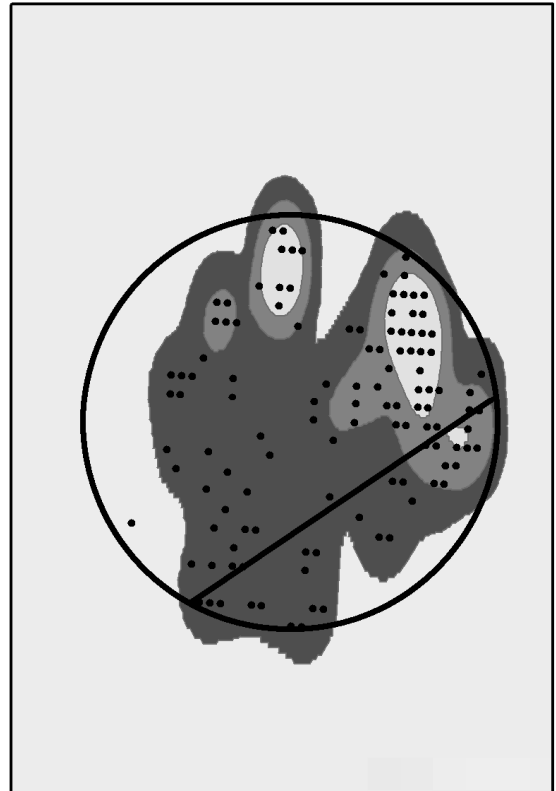
Study species:- Ray (*R. clavata*)

Study period:- Night time looking at total of 10 events (cable switch on's)  
(Event No's:- 39, 41, 43, 45, 47, 49, 51, 53, 61, 63)

Rays  
during night with cable off  
(all revised data)



Rays  
during night when cable on  
(all revised data)



KPDF shading shows the probability density surfaces for 95% (dark grey), 75% (mid grey) and 50% (white)

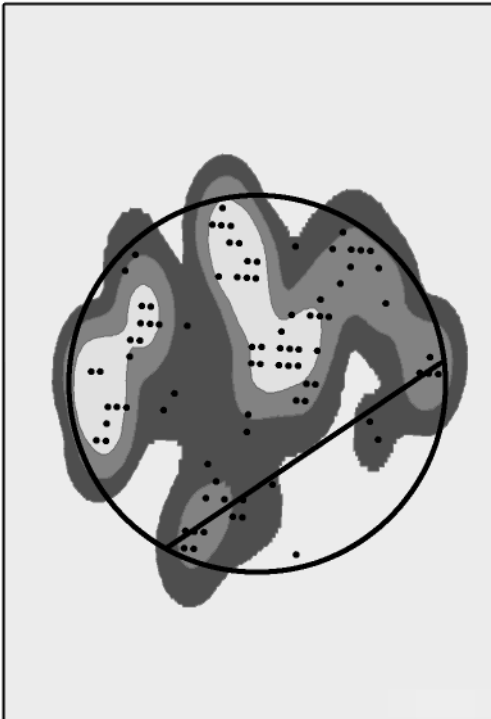
**Trial 1**  
**Detailed spatial distribution in Control Mesocosm**  
**(1hr before, during and after cable switch on's)**

Study species:- Ray (*R.clavata*)

Study period:- Daylight looking at total of 11 events (cable switch on's)

(Event No's:- 38, 40, 42, 44, 46, 48, 50, 52, 54, 60, 62)

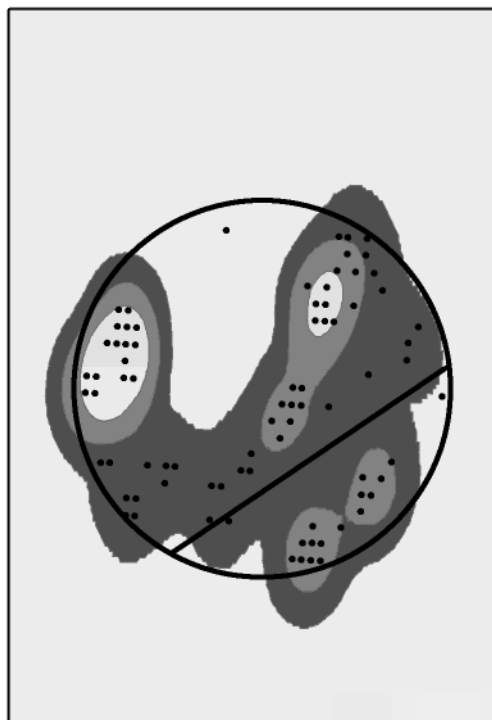
Rays  
Day 1hr before cable on's  
(all revised data)



Rays  
During 1hr cable on's  
(all revised data)



Rays  
1hr after cable on's  
(all revised data)



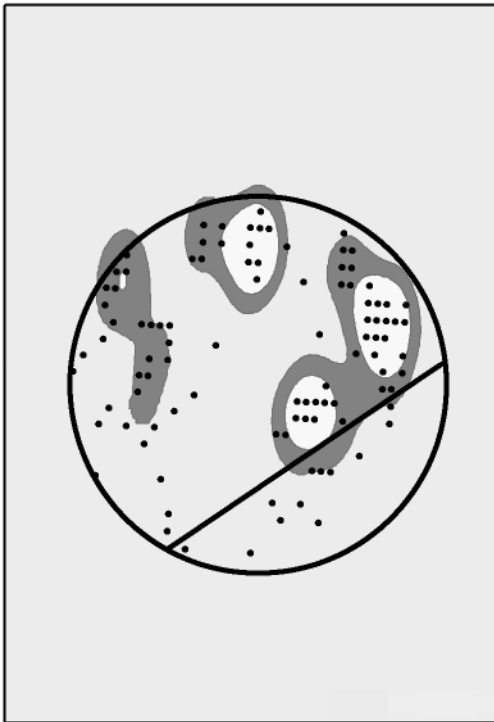
**Trial 1**  
**Detailed spatial distribution in Control Mesocosm**  
**(1hr before, during and after cable switch on's)**

Study species:- Ray (*R.clavata*)

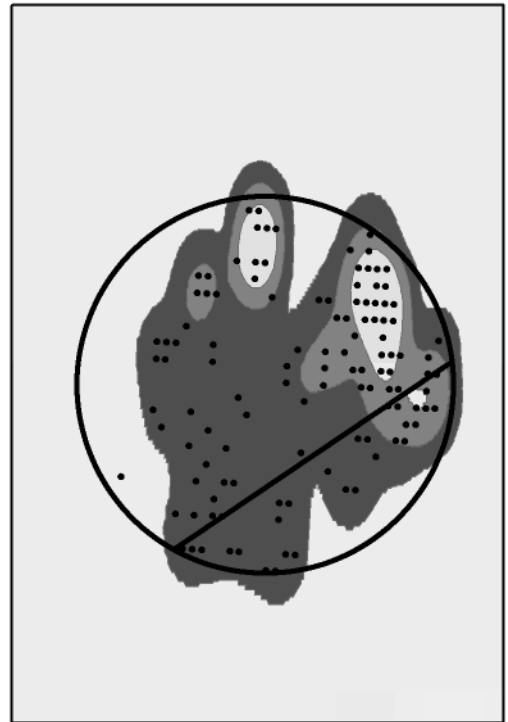
Study period:- Night time looking at total of 10 events (cable switch on's)

(Event No's:- 39, 41, 43, 45, 47, 49, 51, 53, 61, 63)

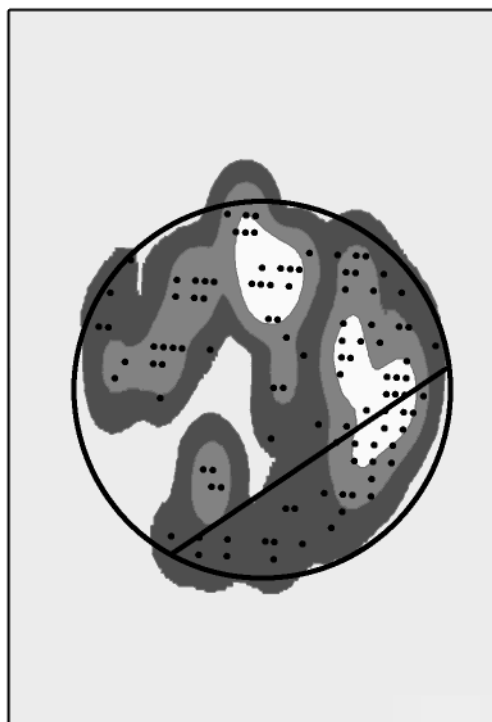
Rays  
Night 1hr before cable on's  
(all revised data)



Rays  
During 1hr cable on's  
(all revised data)



Rays  
1hr after cable on's  
(all revised data)



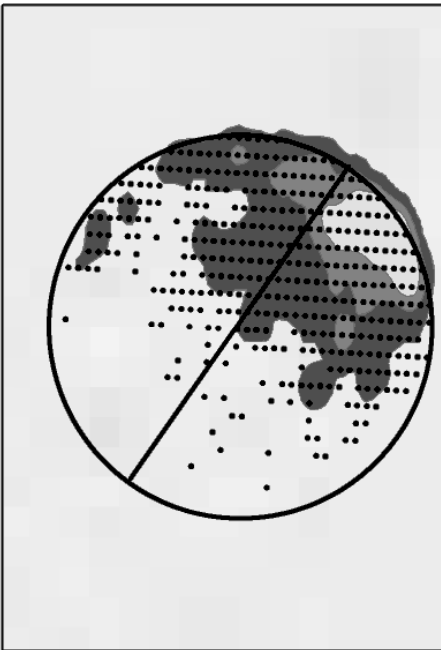
**Trial 1**  
**Detailed spatial distribution in 'Live' Mesocosm**  
**Before and after study period**

Study species:- Ray (*R.clavata*)

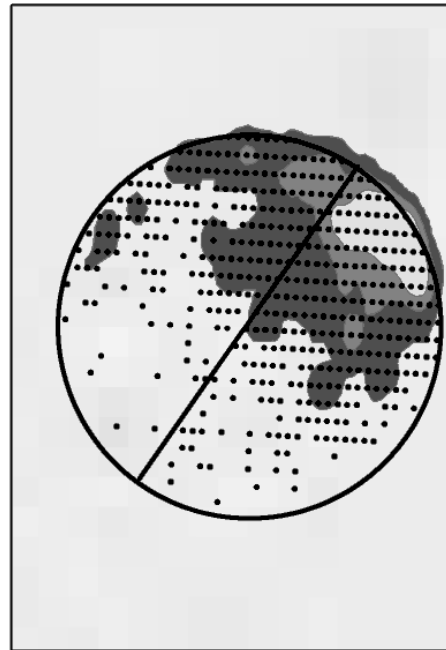
Study period:- Before trials 10/08/2007 – 30/08/2007

After trials 14/09/2007 – 29/09/2007

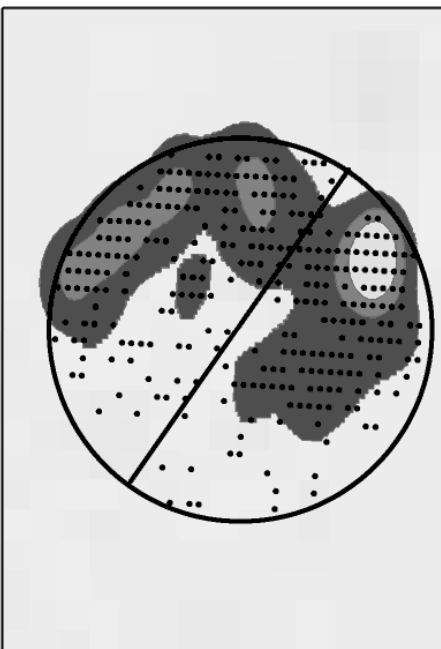
Rays  
Daylight before trials



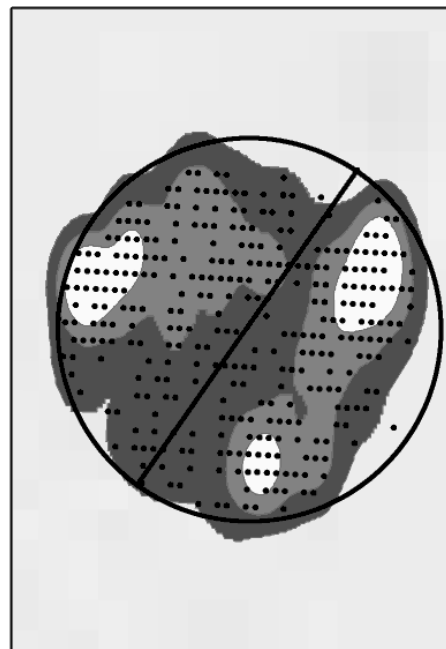
Rays  
Night before trials



Rays  
Daylight after trials



Rays  
Night after trials

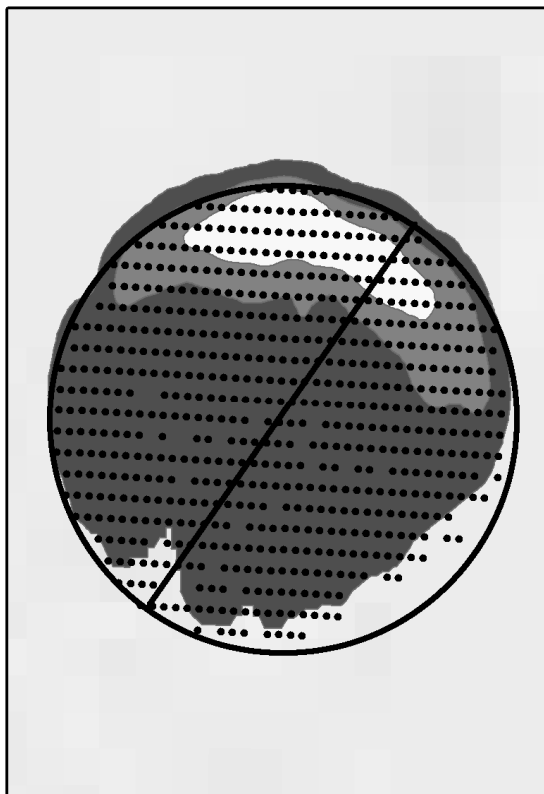


**Trial 1**  
**Overview of spatial distribution in 'Live' Mesocosm**

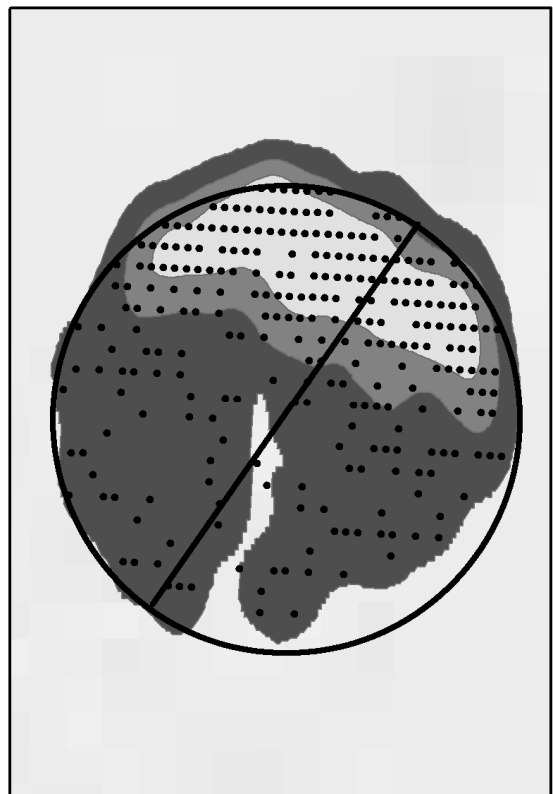
Study species:- Spurdog (*S.acanthia*)

Study period:- Daylight looking at total of 11 events (cable switch on's)  
(Event No's:- 38, 40, 42, 44, 46, 48, 50, 52, 54, 60, 62)

Spurdog during day with cable off  
(all revised data)



Spurdog during day with cable on  
(all revised data)



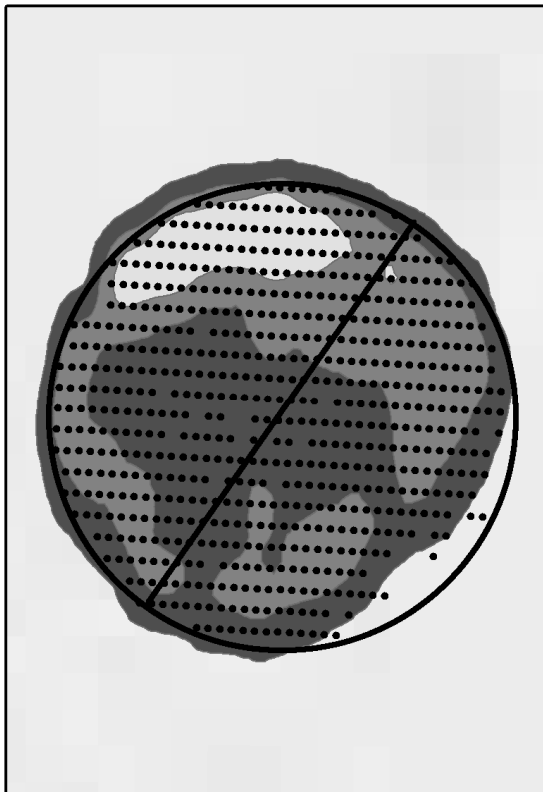
KPDF shading shows the probability density surfaces for 95% (dark grey), 75% (mid grey) and 50% (white)

**Trial 1**  
**Overview of spatial distribution in 'Live' Mesocosm**

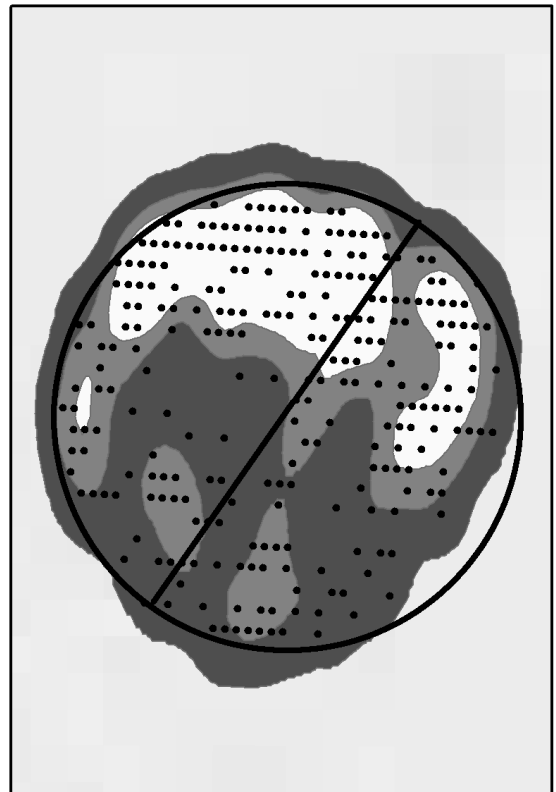
Study species:- Spurdog (*S.acanthia*)

Study period:- Night time looking at total of 10 events (cable switch on's)  
(Event No's:- 39, 41, 43, 45, 47, 49, 51, 53, 61, 63)

Spurdog  
during night with cable off  
(all revised data)



Spurdog  
during night with cable on  
(all revised data)



KPDF shading shows the probability density surfaces for 95% (dark grey), 75% (mid grey) and 50% (white)

**Trial 1**  
**Detailed spatial distribution in 'Live' Mesocosm**  
**(1hr before, during and after cable switch on's)**

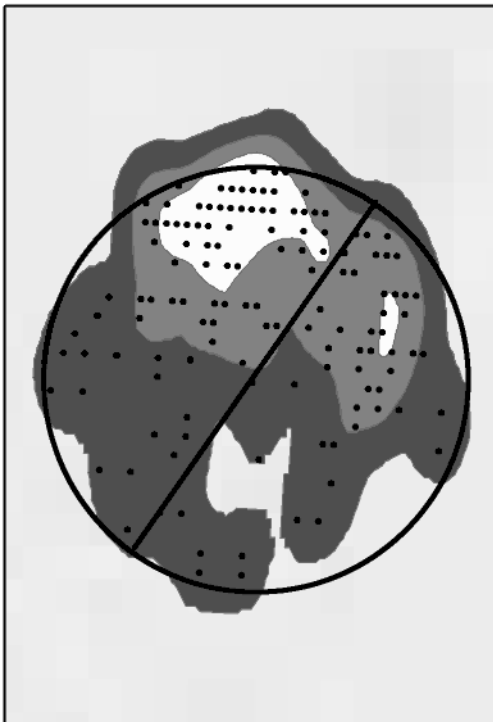
Study species:- Spurdog (*S.acanthia*)

Study period:- Morning (0500 – 1100hrs) looking at total of 5 events

(Event No's:- 44, 46, 50, 54, 62)

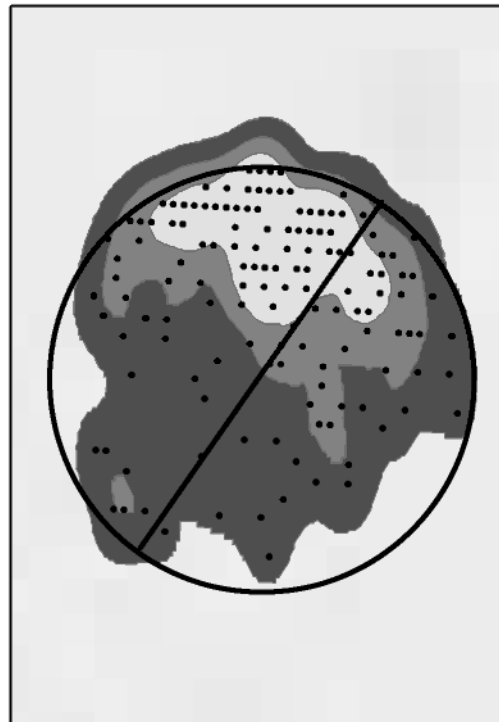
Spurdog

Morning 1hr before cable on's  
(all revised data)



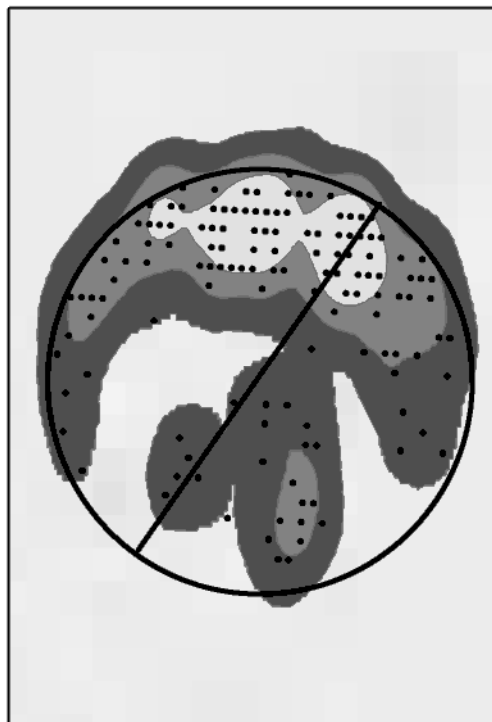
Spurdog

During 1hr cable on's  
(all revised data)



Spurdog

1hr after cable on's  
(all revised data)



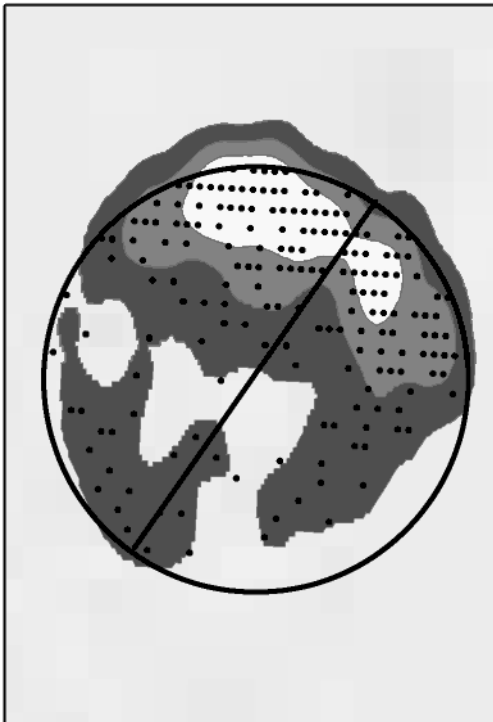


**Trial 1**  
**Detailed spatial distribution in 'Live' Mesocosm**  
**(1hr before, during and after cable switch on's)**

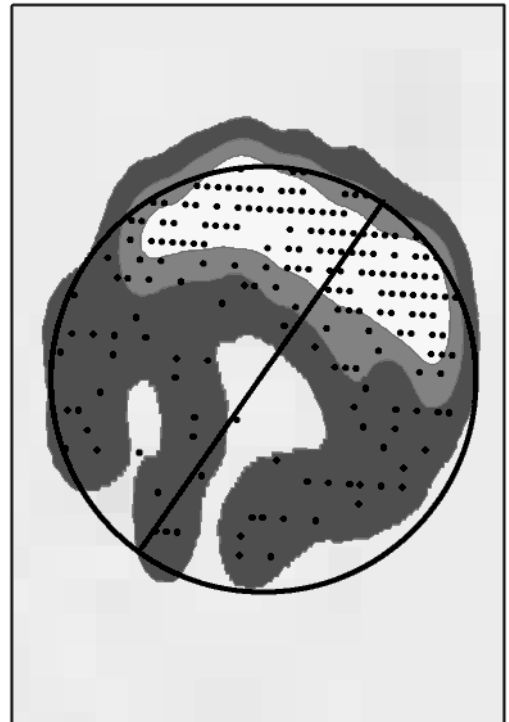
Study species:- Spurdog (*S.acanthia*)

Study period:- Afternoon (1430 – 2000hrs) looking at total of 6 events  
(Event No's:- 38, 40, 42, 48, 52, 60)

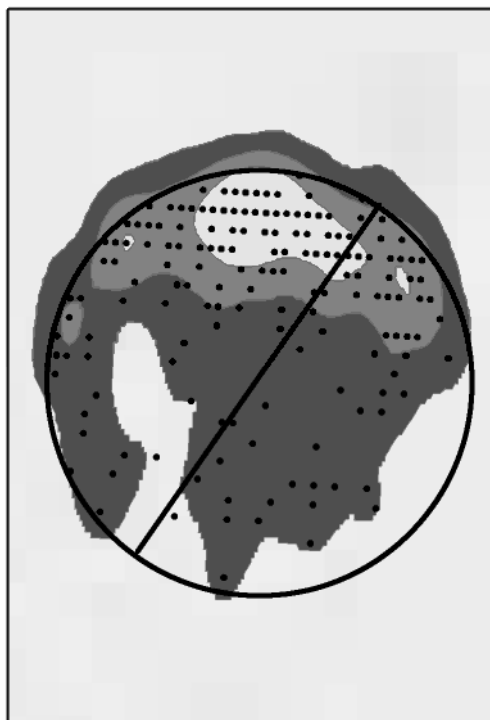
Spurdog  
Afternoon 1hr before cable on's  
(all revised data)



Spurdog  
During 1hr cable on's  
(all revised data)



Spurdog  
1hr after cable on's  
(all revised data)



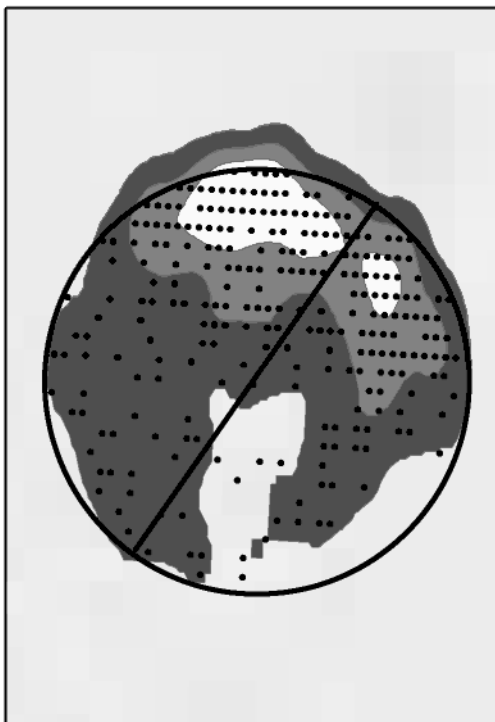
**Trial 1**  
**Detailed spatial distribution in 'Live' Mesocosm**  
**(1hr before, during and after cable switch on's)**

Study species:- Spurdog (*S.acanthia*)

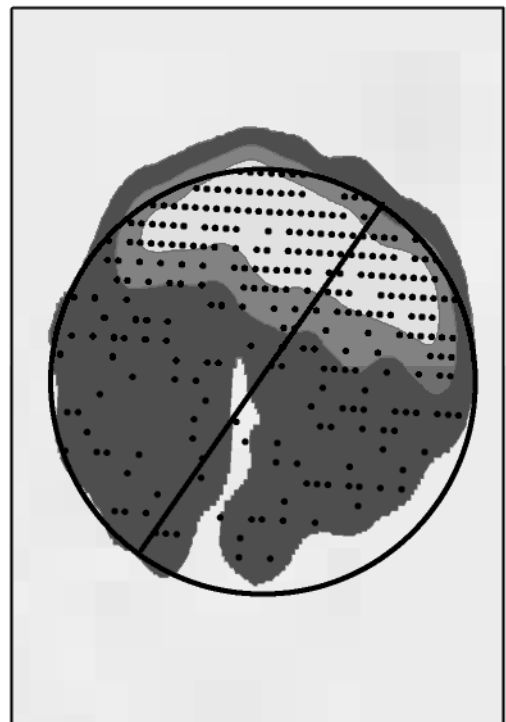
Study period:- Daylight looking at total of 11 events (cable switch on's)

(Event No's:- 38, 40, 42, 44, 46, 48, 50, 52, 54, 60, 62)

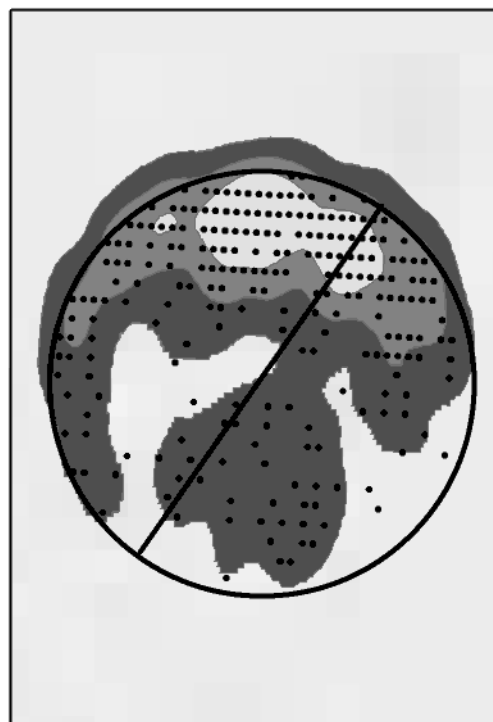
Spurdog  
Day 1hr before cable on's  
(all revised data)



Spurdog  
During 1hr cable on's  
(all revised data)



Spurdog  
1hr after cable on's  
(all revised data)



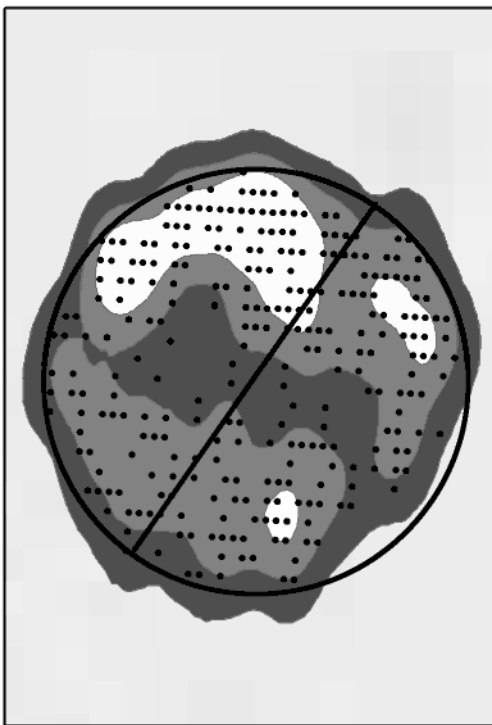
**Trial 1**  
**Detailed spatial distribution in 'Live' Mesocosm**  
**(1hr before, during and after cable switch on's)**

Study species:- Spurdog (*S.acanthia*)

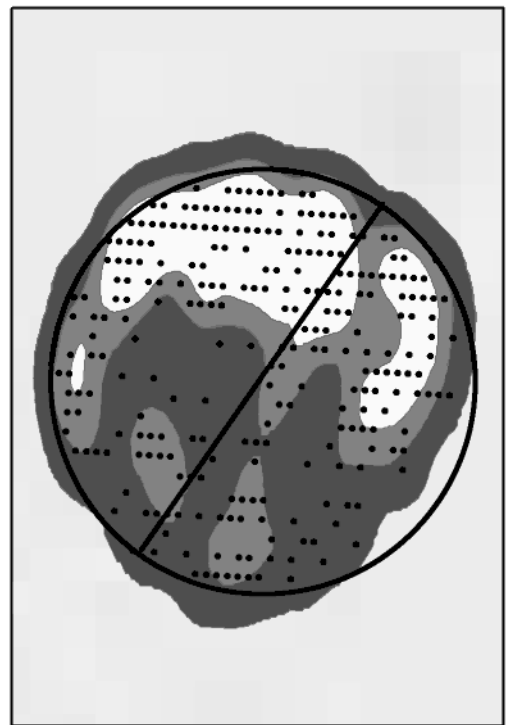
Study period:- Night time looking at total of 10 events (cable switch on's)

(Event No's:- 39, 41, 43, 45, 47, 49, 51, 53, 61, 63)

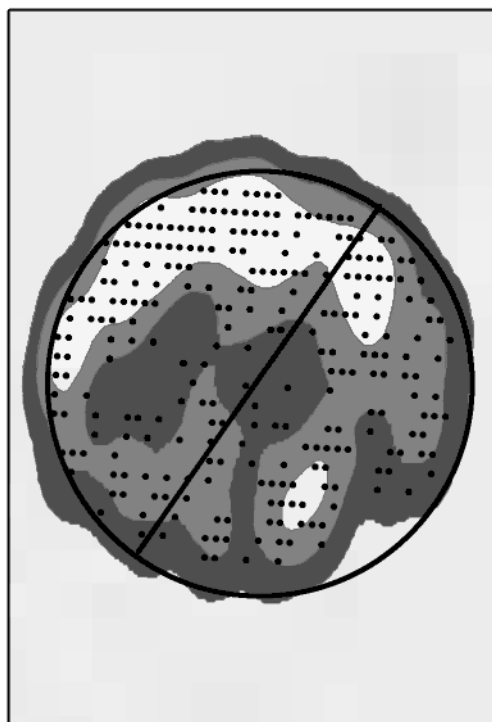
Spurdog  
Night 1hr before cable on's  
(all revised data)



Spurdog  
During 1hr cable on's  
(all revised data)



Spurdog  
1hr after cable on's  
(all revised data)

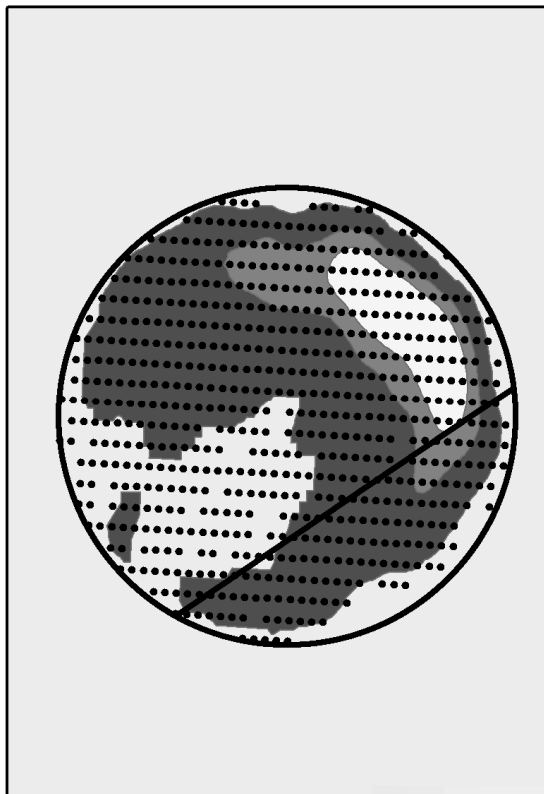


**Trial 1**  
**Overview of spatial distribution in Control Mesocosm**

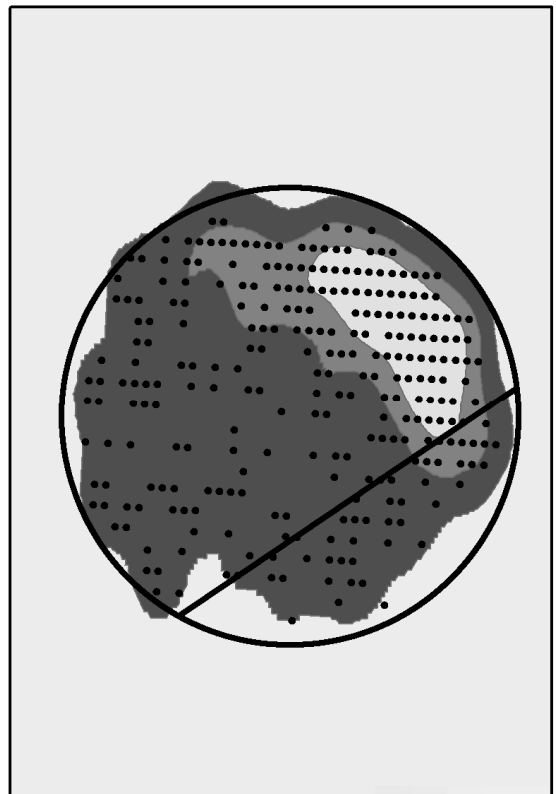
Study species:- Spurdog (*S.acanthia*)

Study period:- Daylight looking at total of 11 events (cable switch on's)  
(Event No's:- 38, 40, 42, 44, 46, 48, 50, 52, 54, 60, 62)

Spurdog during day with cable off  
(all revised data)



Spurdog during day when cable on  
(all revised data)



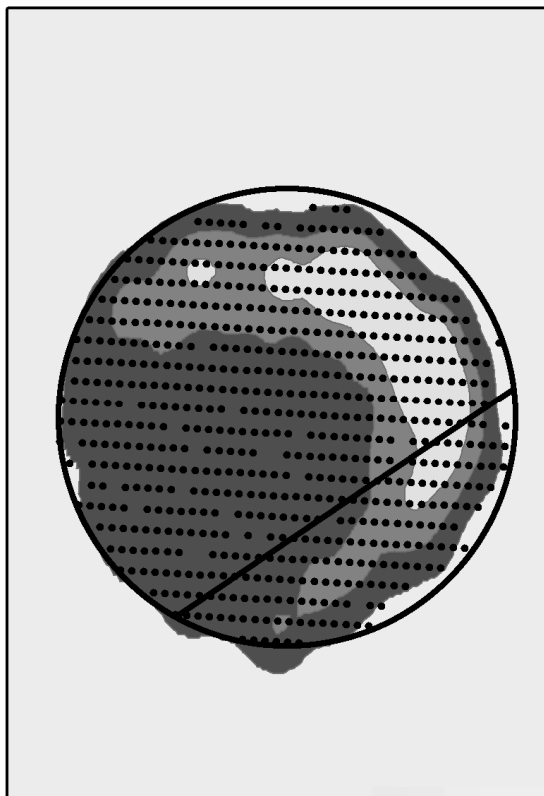
KPDF shading shows the probability density surfaces for 95% (dark grey), 75% (mid grey) and 50% (white)

**Trial 1**  
**Overview of spatial distribution in Control Mesocosm**

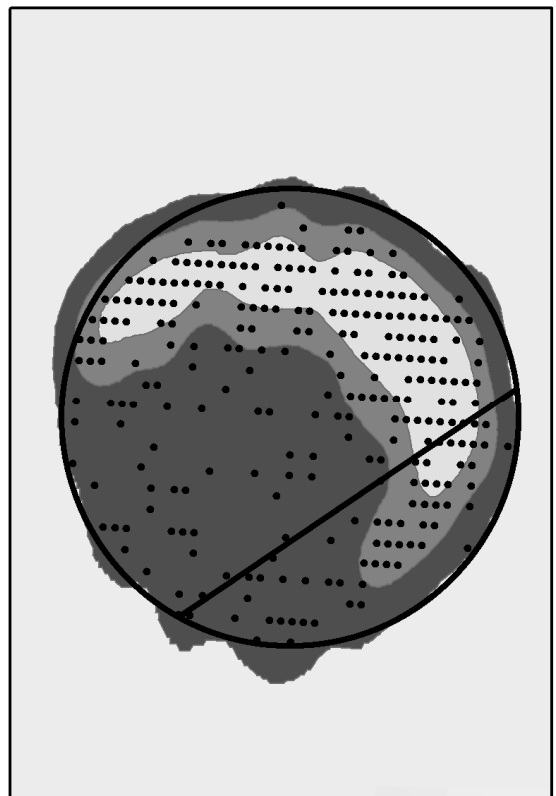
Study species:- Spurdog (*S.acanthia*)

Study period:- Night time looking at total of 10 events (cable switch on's)  
(Event No's:- 39, 41, 43, 45, 47, 49, 51, 53, 61, 63)

Spurdog  
during night with cable off  
(all revised data)



Spurdog  
during night when cable on  
(all revised data)



KPDF shading shows the probability density surfaces for 95% (dark grey), 75% (mid grey) and 50% (white)

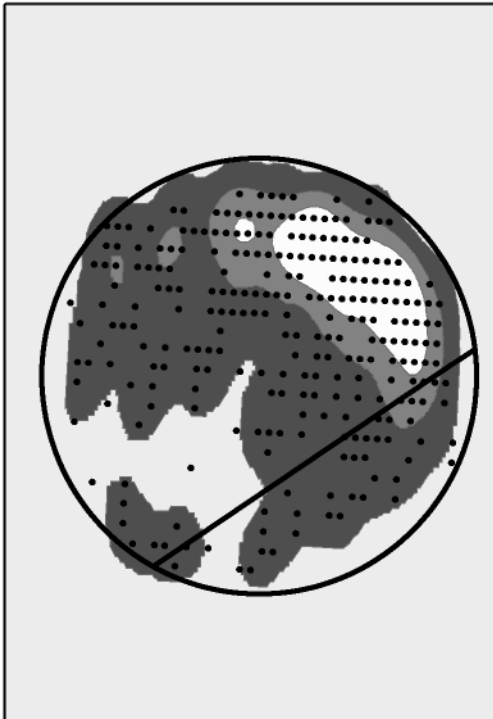
**Trial 1**  
**Detailed spatial distribution in Control Mesocosm**  
**(1hr before, during and after cable switch on's)**

Study species:- Spurdog (*S.acanthia*)

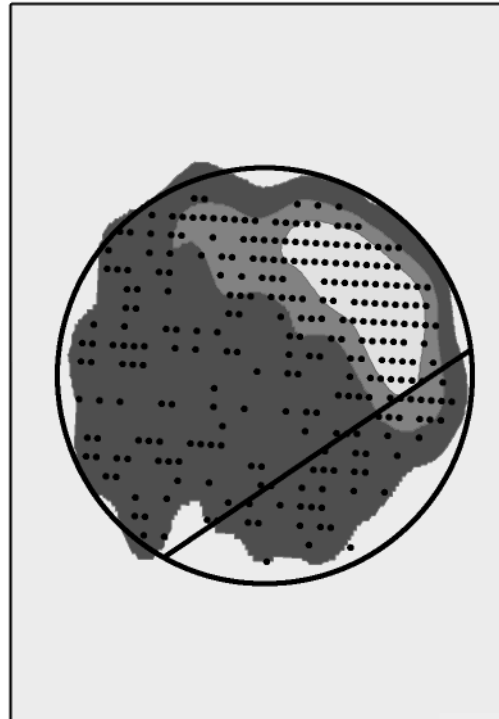
Study period:- Daylight looking at total of 11 events (cable switch on's)

(Event No's:- 38, 40, 42, 44, 46, 48, 50, 52, 54, 60, 62)

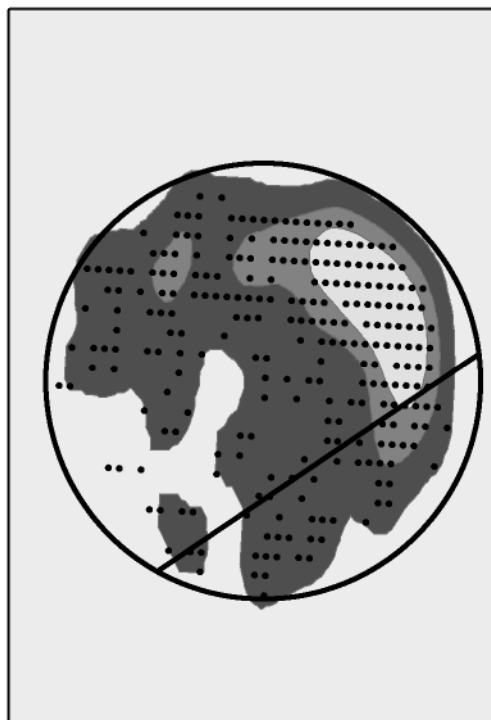
Spurdog  
Day 1hr before cable on's  
(all revised data)



Spurdog  
During 1hr cable on's  
(all revised data)



Spurdog  
1hr after cable on's  
(all revised data)



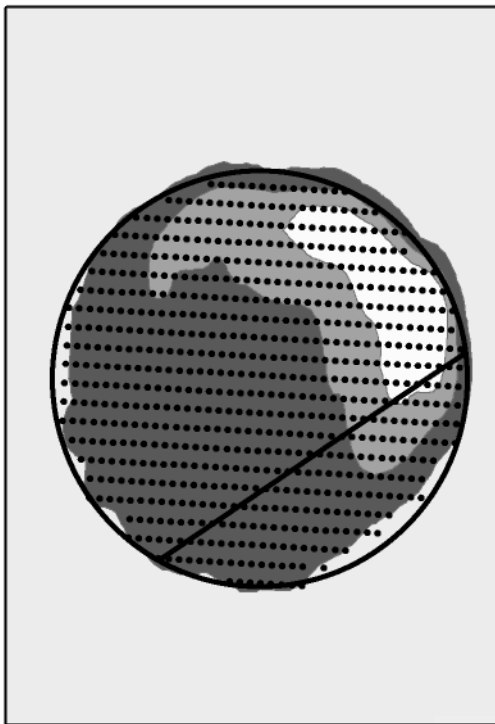
**Trial 1**  
**Detailed spatial distribution in Control Mesocosm**  
**(1hr before, during and after cable switch on's)**

Study species:- Spurdog (*S.acanthia*)

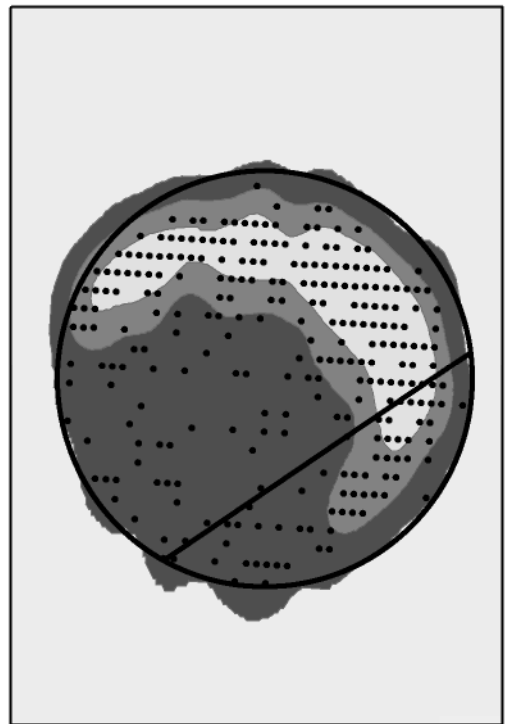
Study period:- Night time looking at total of 10 events (cable switch on's)

(Event No's:- 39, 41, 43, 45, 47, 49, 51, 53, 61, 63)

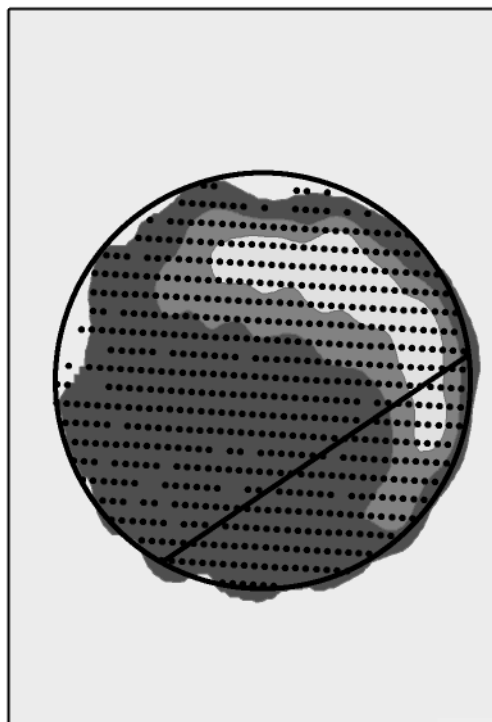
Spurdog  
Night 1hr before cable on's  
(all revised data)



Spurdog  
During 1hr cable on's  
(all revised data)



Spurdog  
1hr after cable on's  
(all revised data)



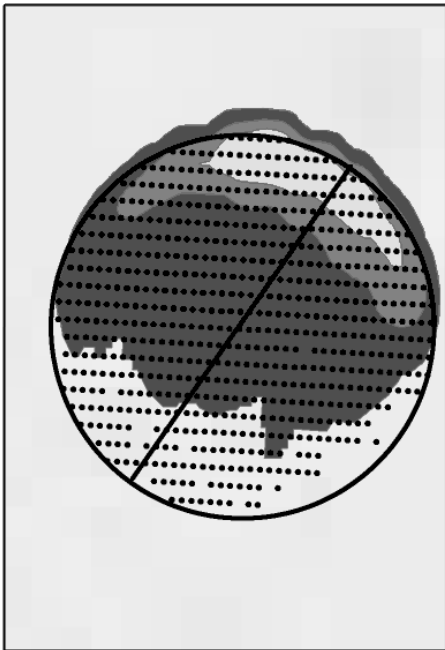
**Trial 1**  
**Detailed spatial distribution in 'Live' Mesocosm**  
**Before and after study period**

Study species:- Spurdog (*S.acanthia*)

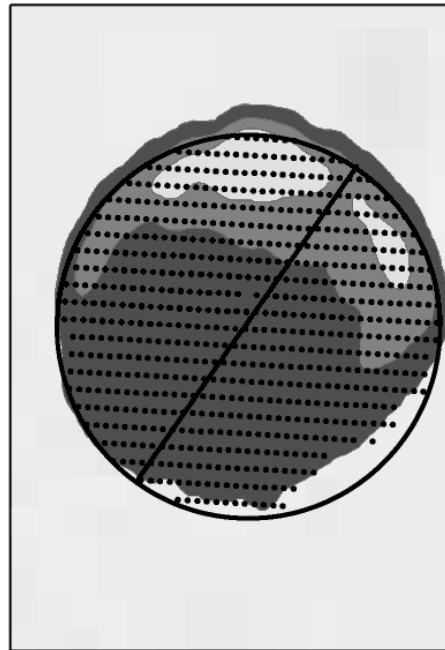
Study period:- Before trials 10/08/2007 – 30/08/2007

After trials 14/09/2007 – 29/09/2007

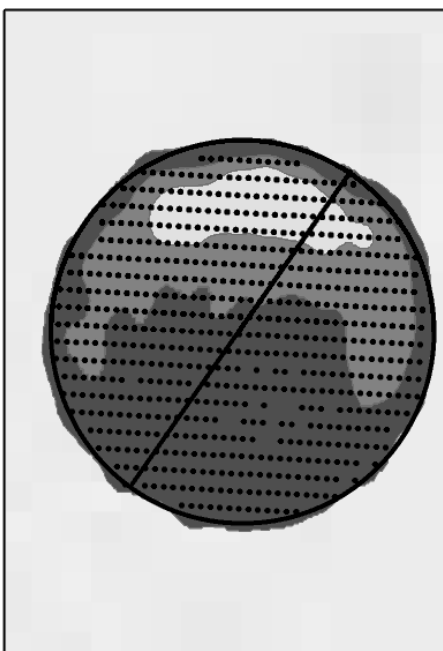
Spurdog  
Daylight before trials



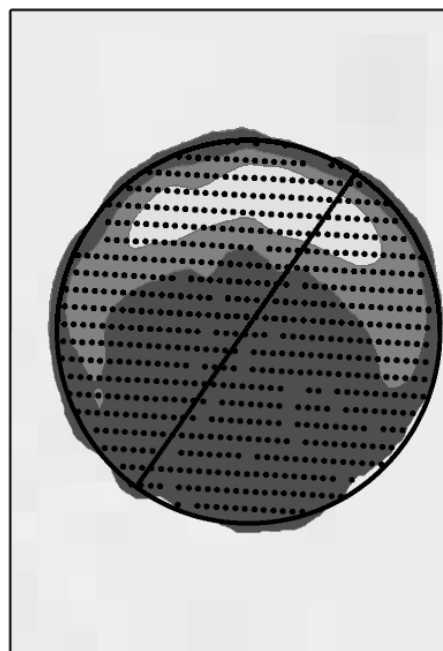
Spurdog  
Night before trials



Spurdog  
Daylight after trials



Spurdog  
Night after trials





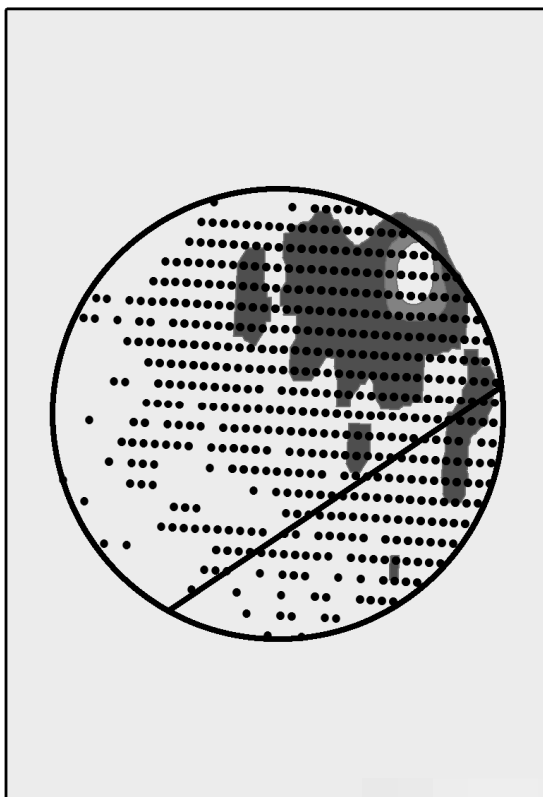
**Trial 2**  
**Overview of spatial distribution in 'Live' Mesocosm**

Study species:- Thornback Ray (*R.clavata*)

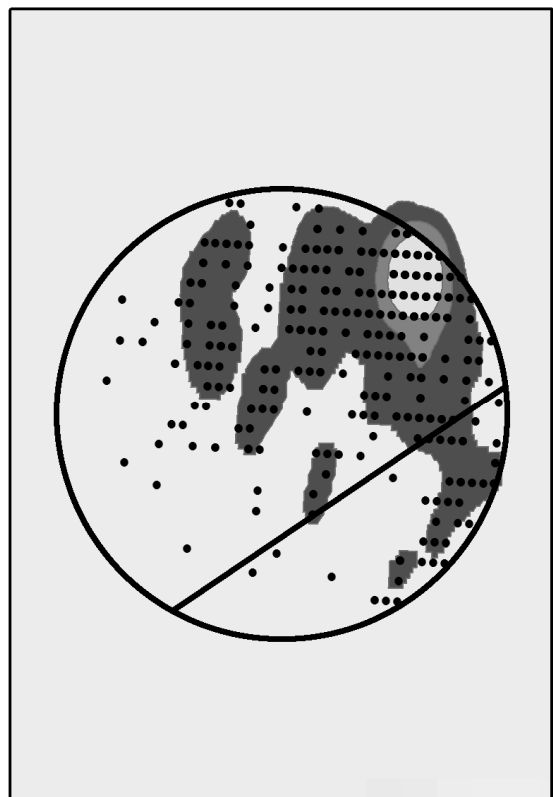
Study period:- Daylight looking at total of 19 events (cable switch on's)

(Event No's:- 1, 3, 5, 7, 9, 11, 13, 17, 19, 21, 22, 23, 25, 27, 29, 31, 33, 35, 37)

Rays during day with cable off  
(all revised data)



Rays during day with cable on  
(all revised data)



KPDF shading shows the probability density surfaces for 95% (dark grey), 75% (mid grey) and 50% (white)

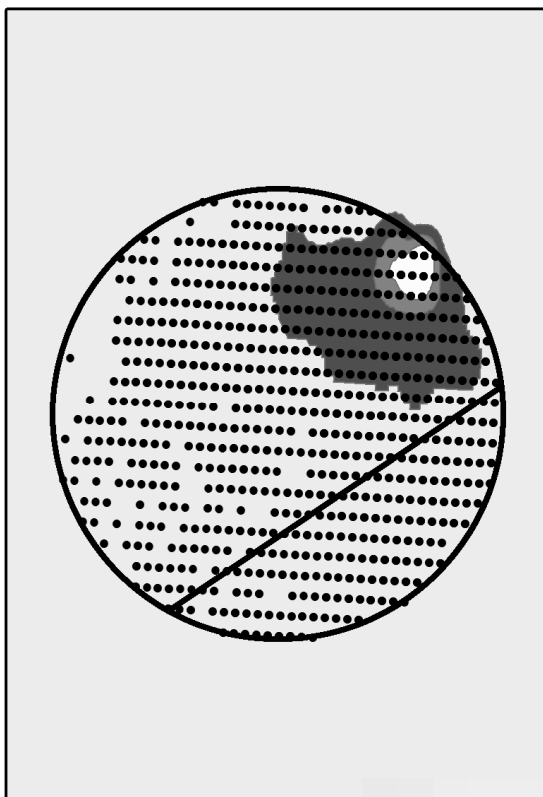
**Trial 2**  
**Overview of spatial distribution in 'Live' Mesocosm**

Study species:- Thornback Ray (*R.clavata*)

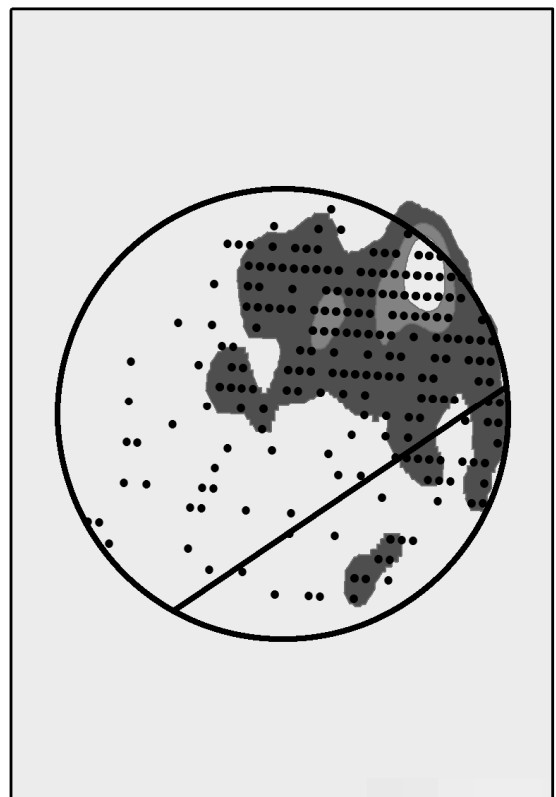
Study period:- Night time looking at total of 15 events (cable switch on's)

(Event No's:- 2, 4, 8, 10, 12, 14, 18, 20, 24, 26, 30, 32, 34, 36, 38)

Rays during night with cable off  
(all revised data)



Rays during night with cable on  
(all revised data)



KPDF shading shows the probability density surfaces for 95% (dark grey), 75% (mid grey) and 50% (white)

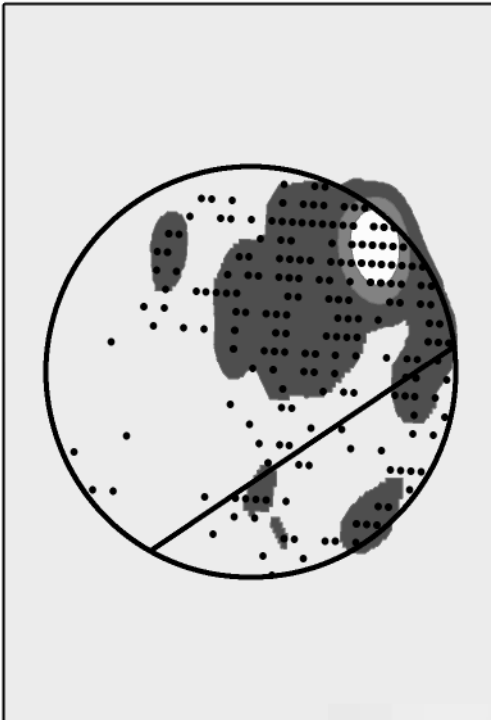
**Trial 2**  
**Detailed spatial distribution in 'Live' Mesocosm**  
**(1hr before, during and after cable switch on's)**

Study species:- Thornback Ray (*R.clavata*)

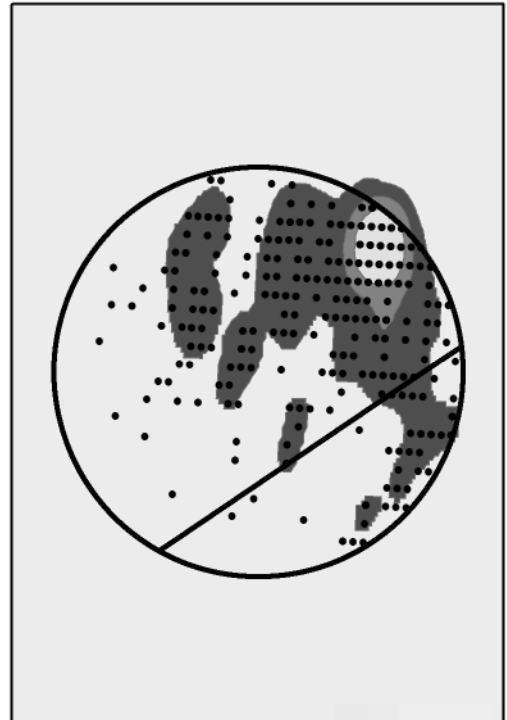
Study period:- Daylight looking at total of 19 events (cable switch on's)

(Event No's:- 1, 3, 5, 7, 9, 11, 13, 17, 19, 21, 22, 23, 25, 27, 29, 31, 33, 35, 37)

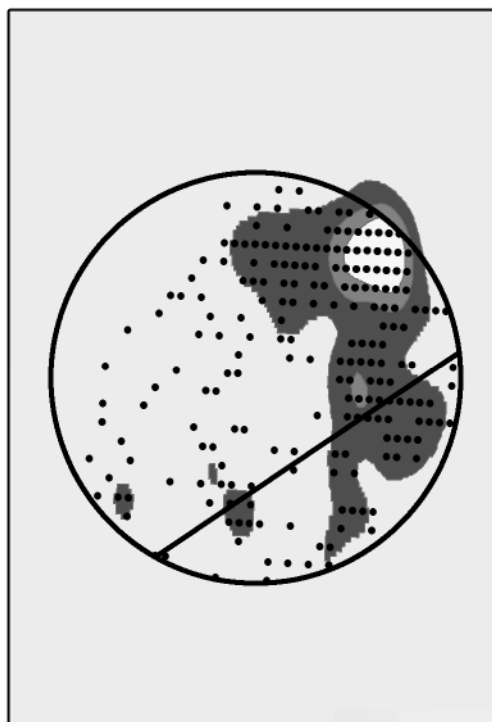
Rays  
Day 1hr before cable on's  
(all revised data)



Rays  
During 1hr cable on's  
(all revised data)



Rays  
1hr after cable on's  
(all revised data)



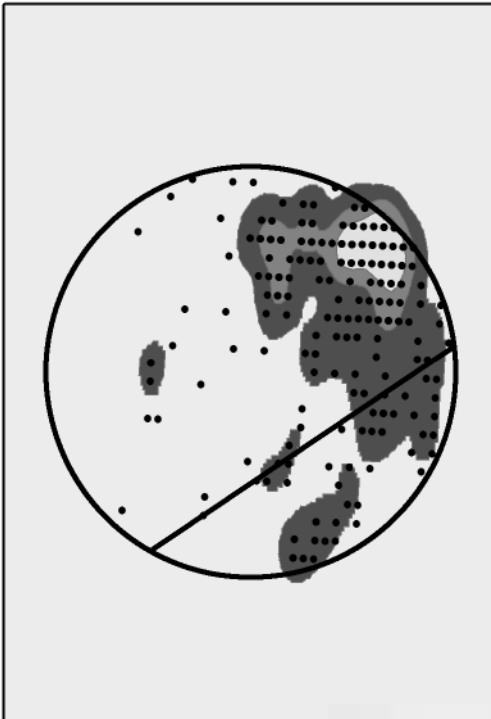
**Trial 2**  
**Detailed spatial distribution in 'Live' Mesocosm**  
**(1hr before, during and after cable switch on's)**

Study species:- Thornback Ray (*R.clavata*)

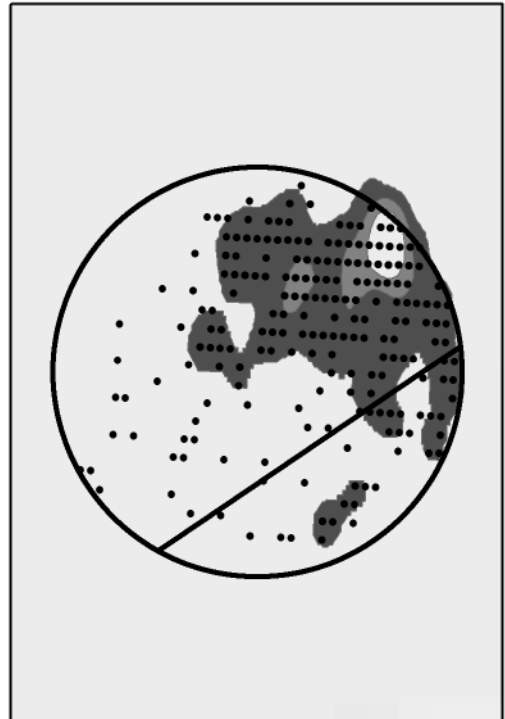
Study period:- Night time looking at total of 15 events (cable switch on's)

(Event No's:- 2, 4, 8, 10, 12, 14, 18, 20, 24, 26, 30, 32, 34, 36, 38)

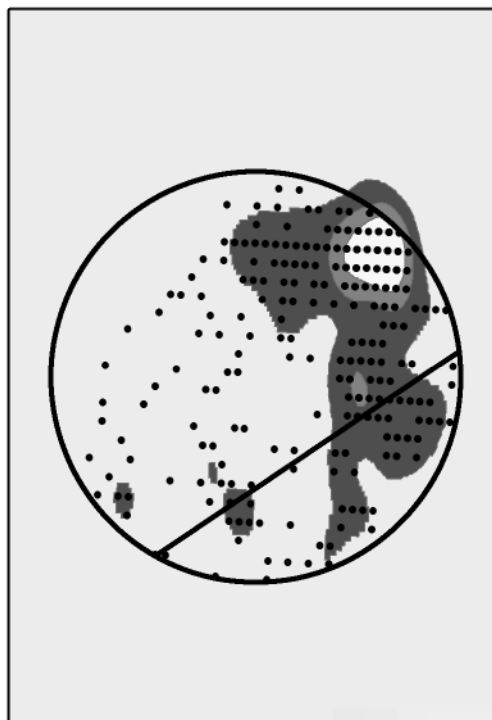
Rays  
Night 1hr before cable on's  
(all revised data)



Rays  
During 1hr cable on's  
(all revised data)



Rays  
1hr after cable on's  
(all revised data)



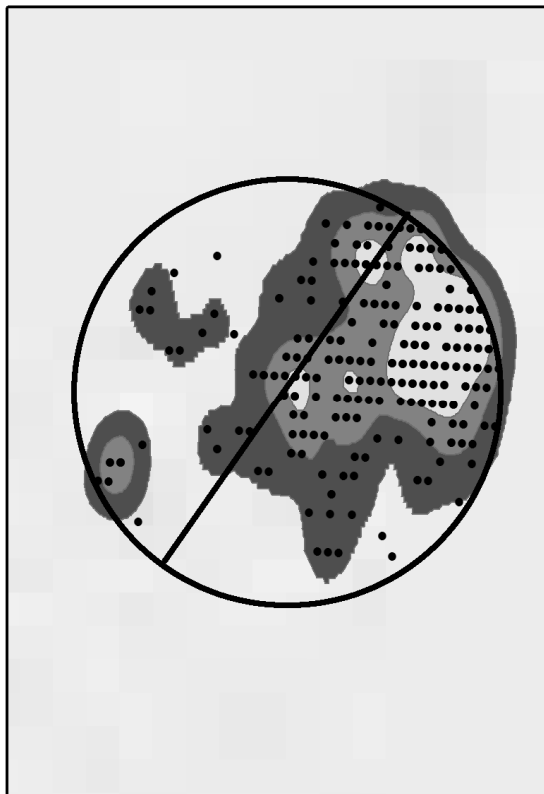
**Trial 2**  
**Overview of spatial distribution in 'Control' Mesocosm**

Study species:- Thornback Ray (*R.clavata*)

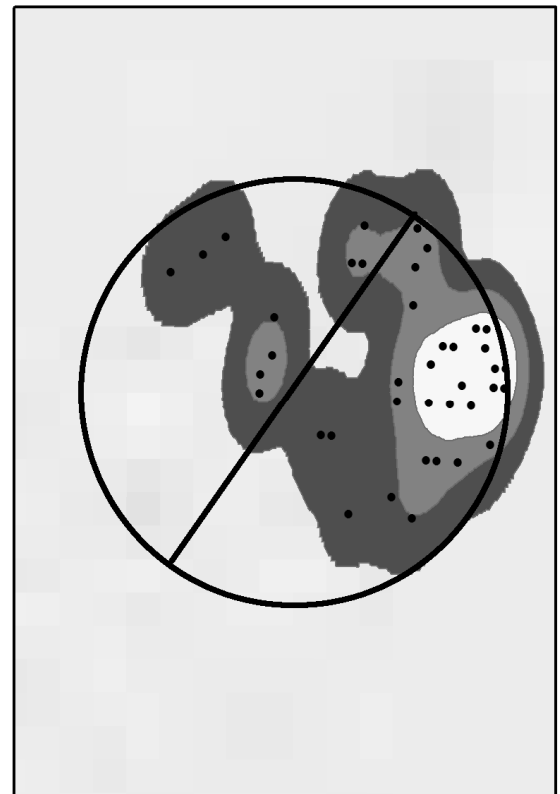
Study period:- Daylight looking at total of 19 events (cable switch on's)

(Event No's:- 1, 3, 5, 7, 9, 11, 13, 17, 19, 21, 22, 23, 25, 27, 29, 31, 33, 35, 37)

Rays during day with cable off  
(all revised data)



Rays during day with cable on  
(all revised data)



KPDF shading shows the probability density surfaces for 95% (dark grey), 75% (mid grey) and 50% (white)

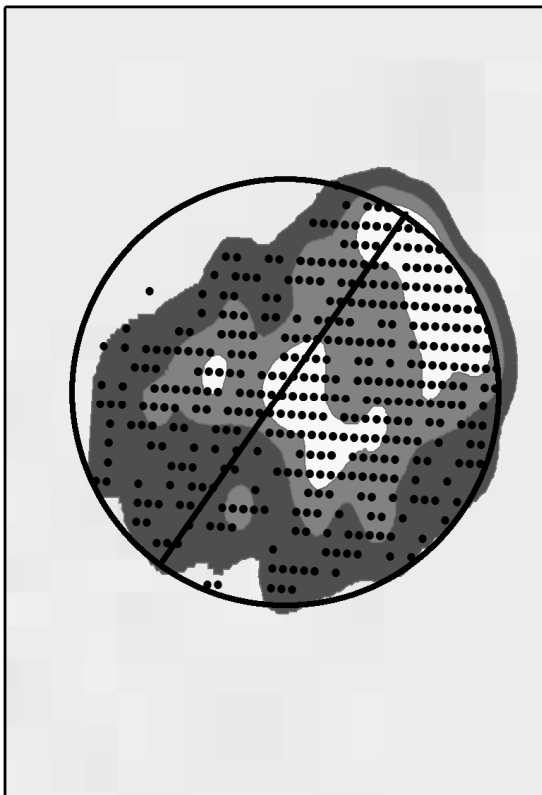
**Trial 2**  
**Overview of spatial distribution in 'Control' Mesocosm**

Study species:- Thornback Ray (*R.clavata*)

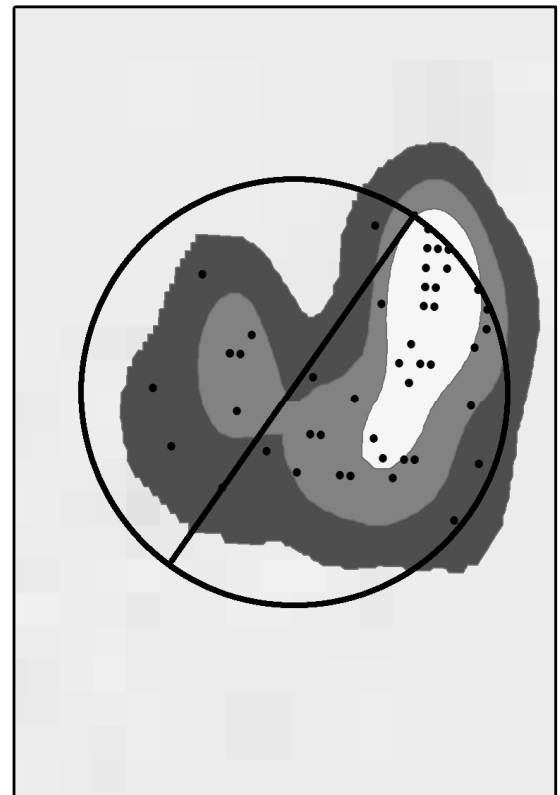
Study period:- Night time looking at total of 15 events (cable switch on's)

(Event No's:- 2, 4, 8, 10, 12, 14, 18, 20, 24, 26, 30, 32, 34, 36, 38)

Rays during night with cable off  
(all revised data)



Rays during night with cable on  
(all revised data)



KPDF shading shows the probability density surfaces for 95% (dark grey), 75% (mid grey) and 50% (white)

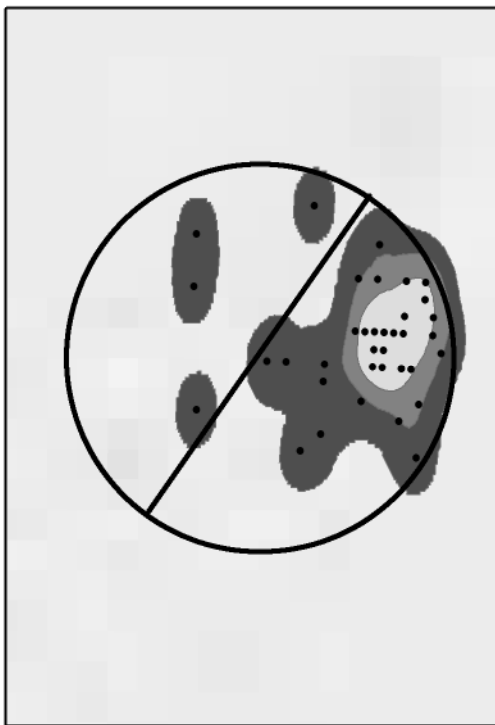
**Trial 2**  
**Detailed spatial distribution in 'Control' Mesocosm**  
**(1hr before, during and after cable switch on's)**

Study species:- Thornback Ray (*R.clavata*)

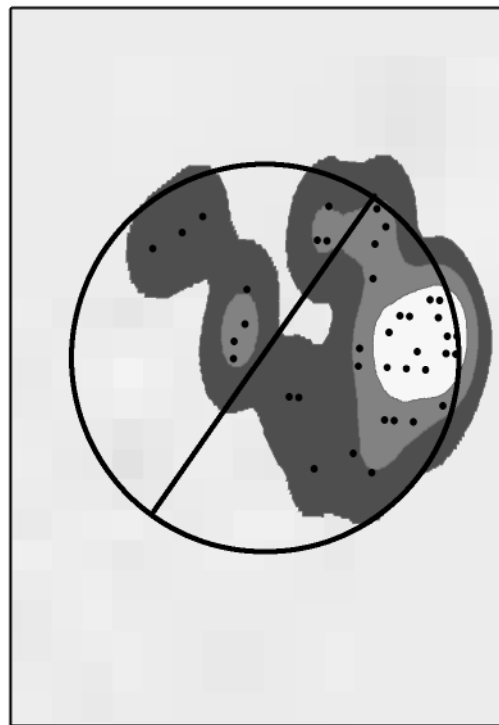
Study period:- Daylight looking at total of 19 events (cable switch on's)

(Event No's:- 1, 3, 5, 7, 9, 11, 13, 17, 19, 21, 22, 23, 25, 27, 29, 31, 33, 35, 37)

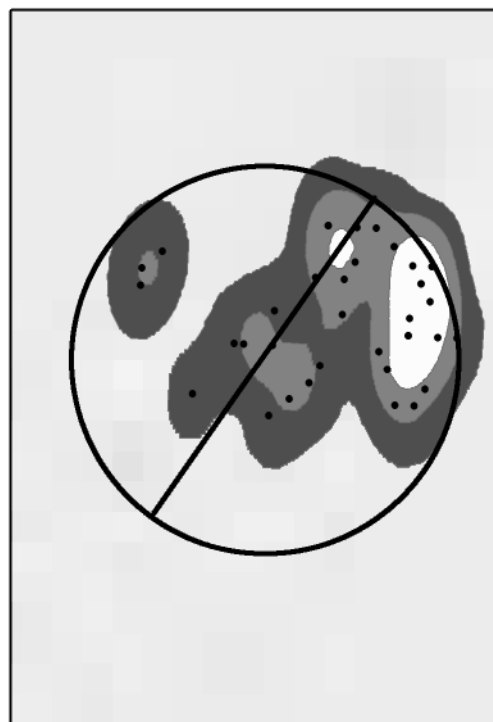
Rays  
Day 1hr before cable on's  
(all revised data)



Rays  
During 1hr cable on's  
(all revised data)



Rays  
1hr after cable on's  
(all revised data)



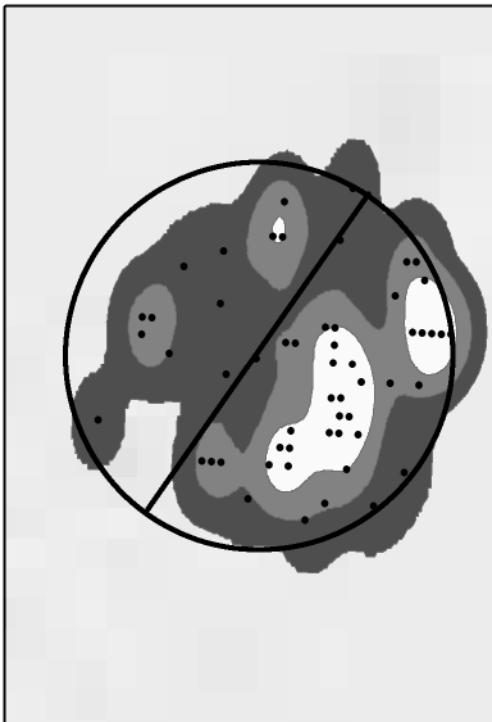
**Trial 2**  
**Detailed spatial distribution in 'Control' Mesocosm**  
**(1hr before, during and after cable switch on's)**

Study species:- Thornback Ray (*R.clavata*)

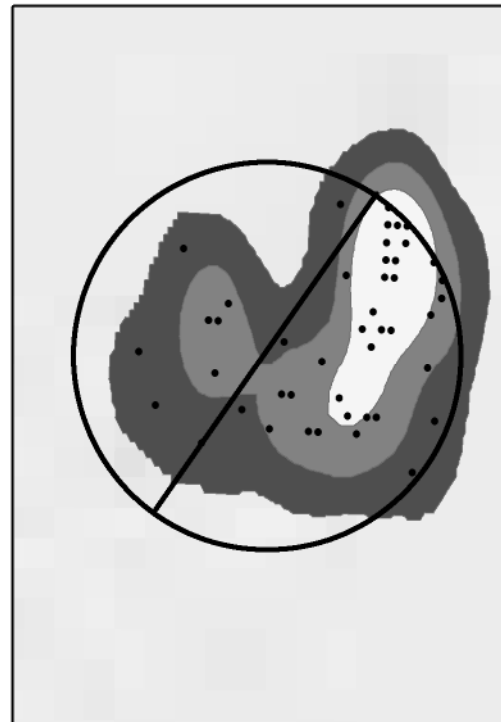
Study period:- Night time looking at total of 15 events (cable switch on's)

(Event No's:- 2, 4, 8, 10, 12, 14, 18, 20, 24, 26, 30, 32, 34, 36, 38)

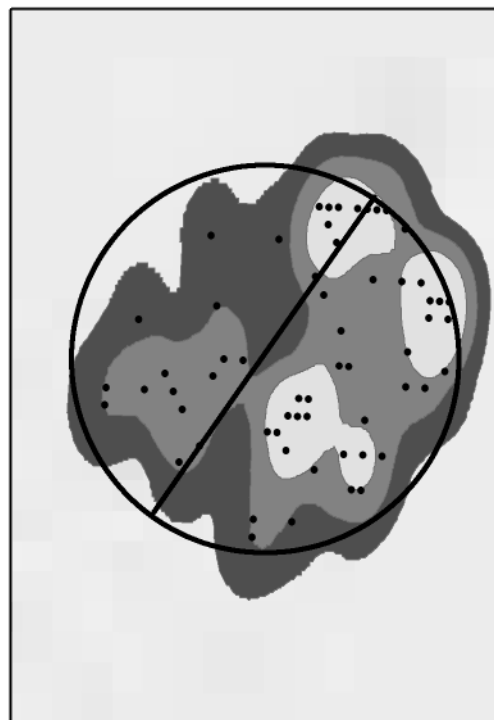
Rays  
Night 1hr before cable on's  
(all revised data)



Rays  
During 1hr cable on's  
(all revised data)



Rays  
1hr after cable on's  
(all revised data)





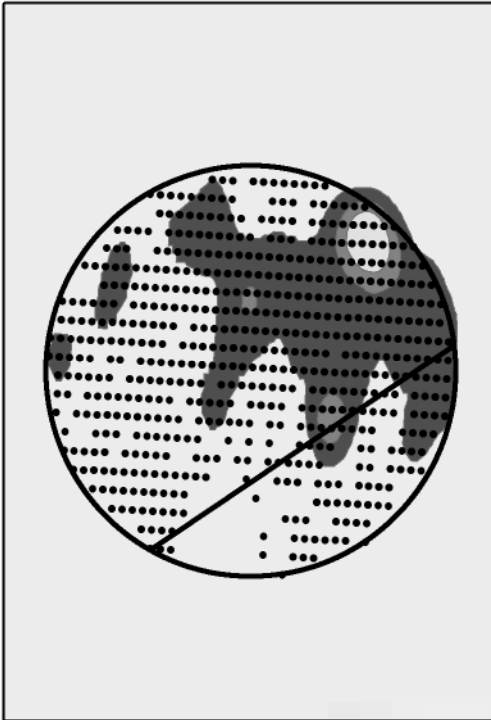
**Trial 2**  
**Detailed spatial distribution in 'Live' Mesocosm**  
**Before and after study period**

Study species:- Thornback Ray (*R.clavata*)

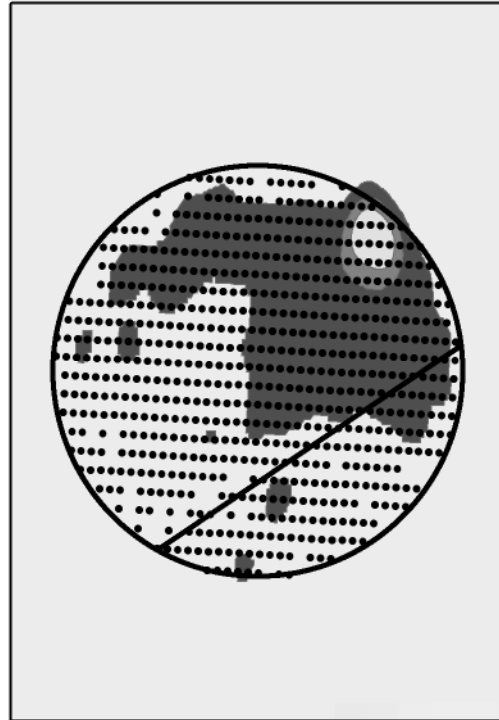
Study period:- Before trial:- 03/10/2007 – 15/10/2007

After trial:- 04/11/2007 – 19/11/2007

Rays  
Daylight before trial



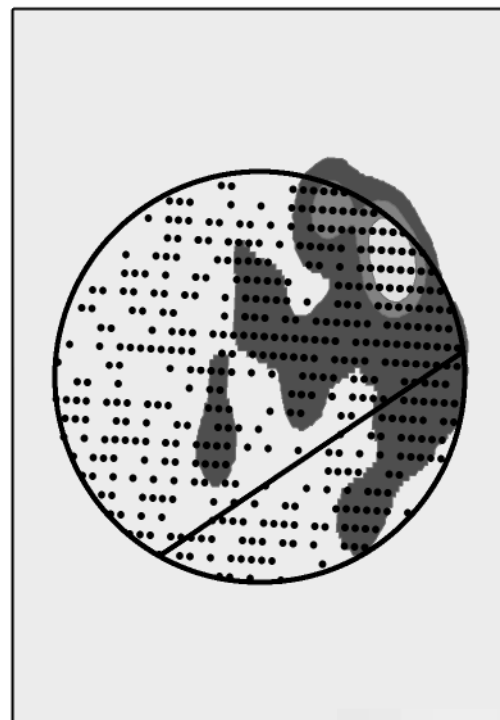
Rays  
Night before trial



Rays  
Daylight after trial



Rays  
Night after trial



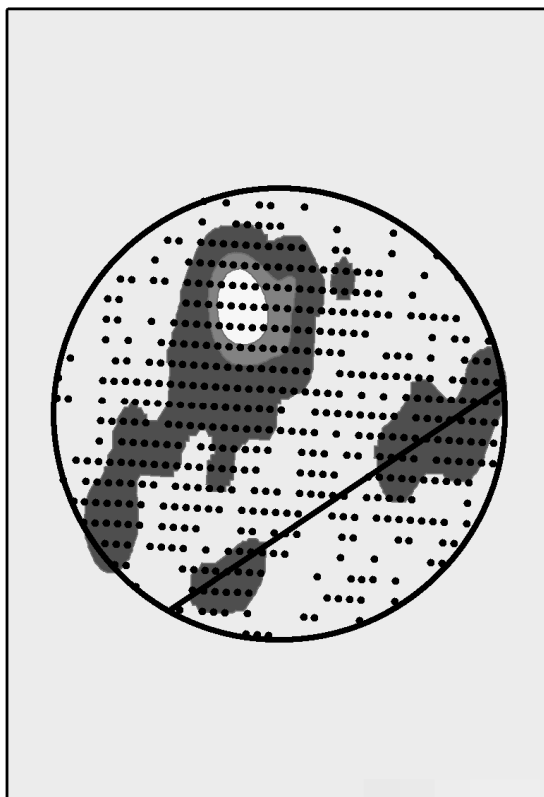
**Trial 2**  
**Overview of spatial distribution in 'Live' Mesocosm**

Study species:- Dogfish (*S.canicula*)

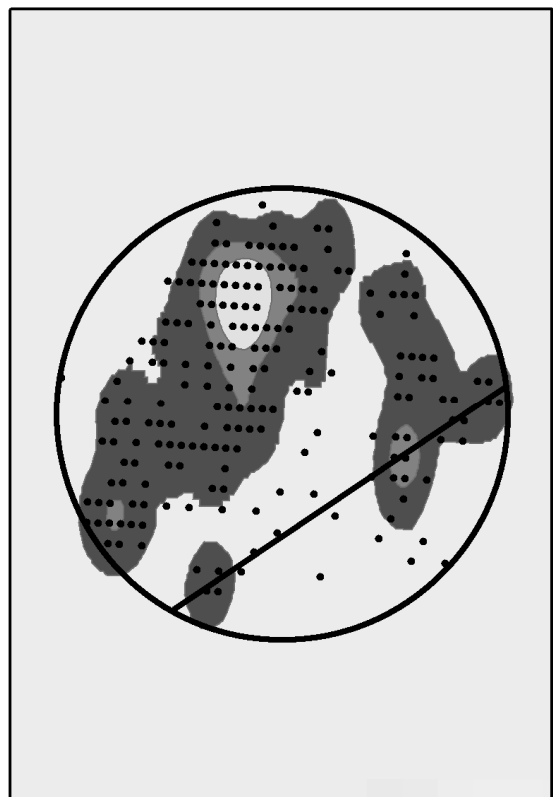
Study period:- Daylight looking at total of 19 events (cable switch on's)

(Event No's:- 1, 3, 5, 7, 9, 11, 13, 17, 19, 21, 22, 23, 25, 29, 31, 33, 35, 37)

Dogfish during day with cable off  
(all revised data)



Dogfish during day with cable on  
(all revised data)



KPDF shading shows the probability density surfaces for 95% (dark grey), 75% (mid grey) and 50% (white)

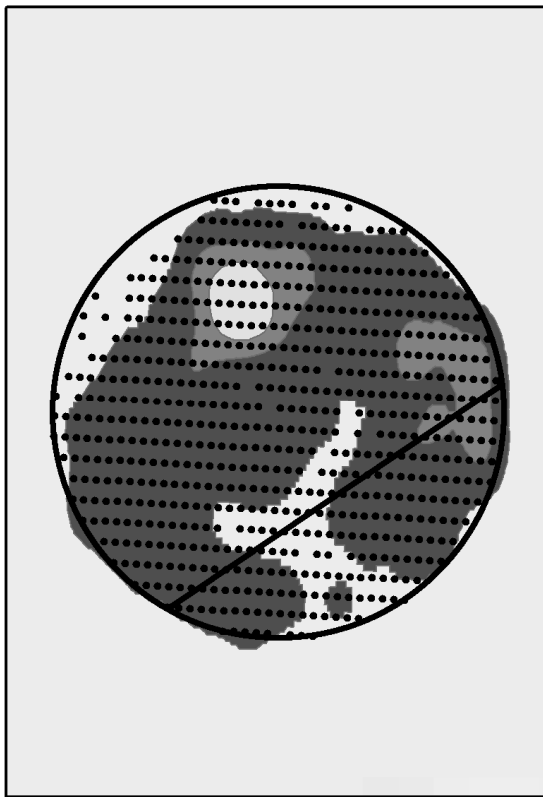
**Trial 2**  
**Overview of spatial distribution in 'Live' Mesocosm**

Study species:- Dogfish (*S.canicula*)

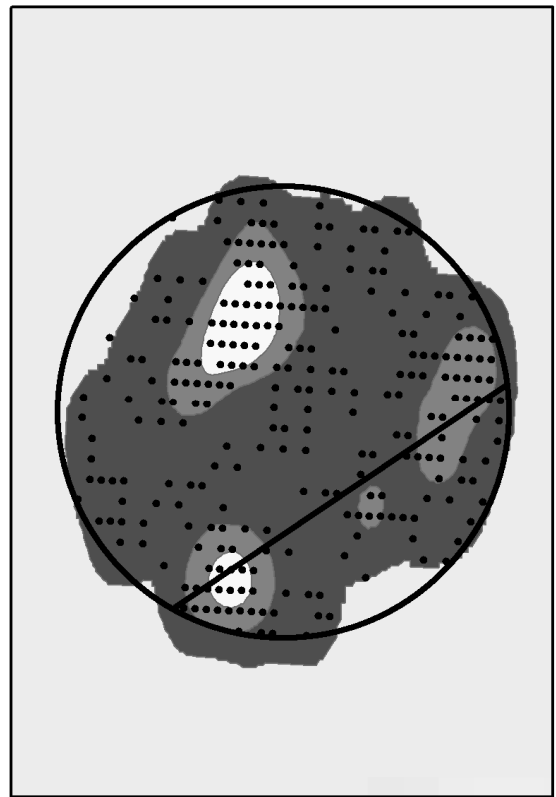
Study period:- Night time looking at total of 15 events (cable switch on's)

(Event No's:- 2, 4, 8, 10, 12, 14, 18, 20, 24, 26, 30, 32, 34, 36, 38)

Dogfish during night with cable off  
(all revised data)



Dogfish during night with cable on  
(all revised data)



KPDF shading shows the probability density surfaces for 95% (dark grey), 75% (mid grey) and 50% (white)

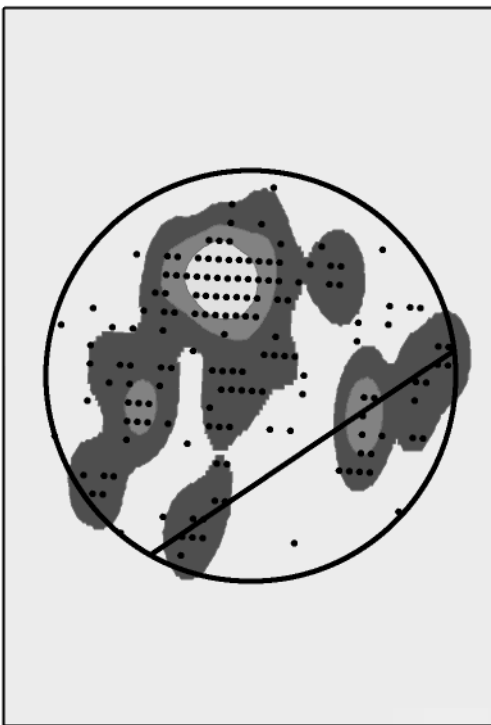
**Trial 2**  
**Detailed spatial distribution in 'Live' Mesocosm**  
**(1hr before, during and after cable switch on's)**

Study species:- Dogfish (*S.canicula*)

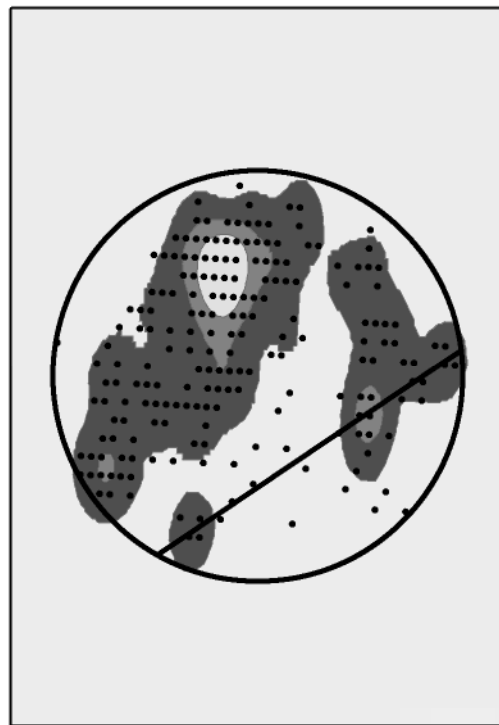
Study period:- Daylight looking at total of 19 events (cable switch on's)

(Event No's:- 1, 3, 5, 7, 9, 11, 13, 17, 19, 21, 22, 23, 25, 29, 31, 33, 35, 37)

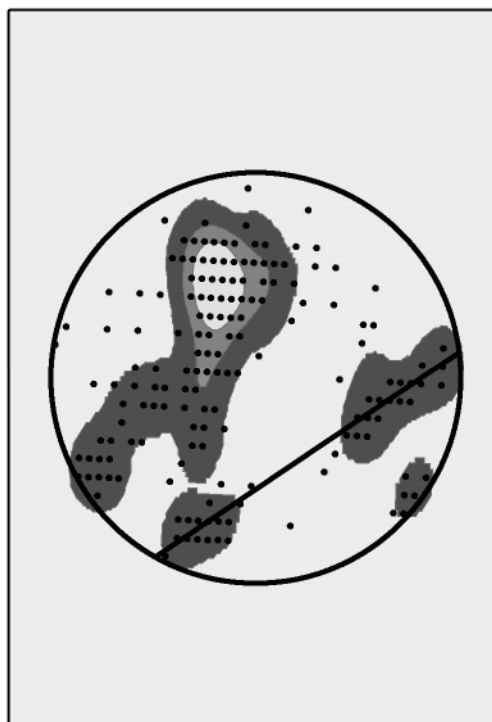
Dogfish  
Day 1hr before cable on's  
(all revised data)



Dogfish  
During 1hr cable on's  
(all revised data)



Dogfish  
1hr after cable on's  
(all revised data)



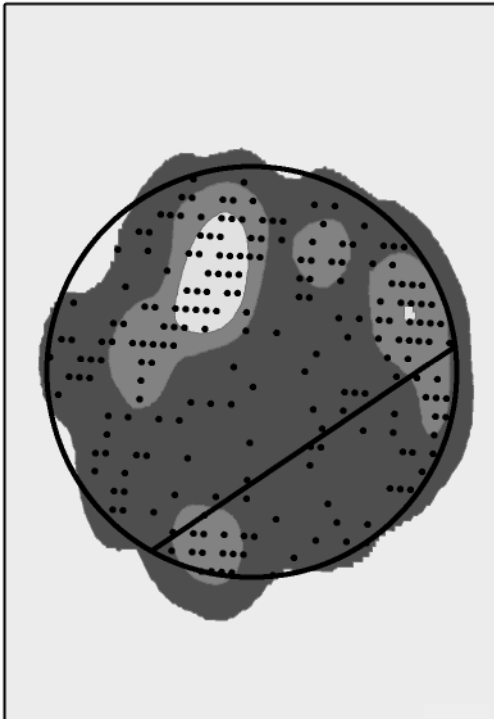
**Trial 2**  
**Detailed spatial distribution in 'Live' Mesocosm**  
**(1hr before, during and after cable switch on's)**

Study species:- Dogfish (*S.canicula*)

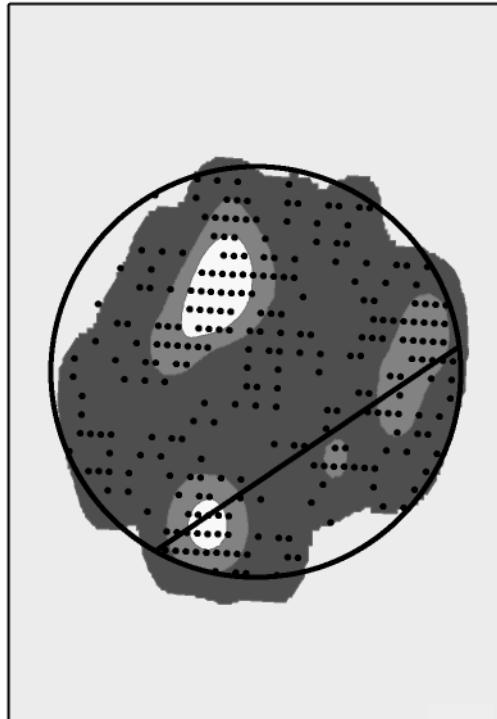
Study period:- Night time looking at total of 15 events (cable switch on's)

(Event No's:- 2, 4, 8, 10, 12, 14, 18, 20, 24, 26, 30, 32, 34, 36, 38)

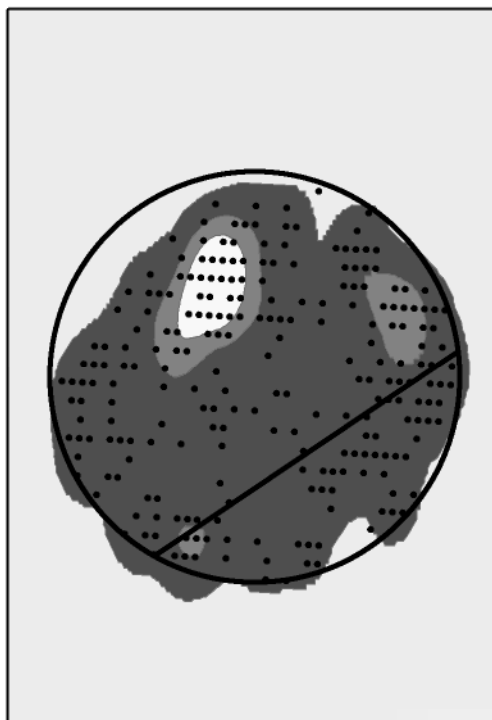
Dogfish  
Night 1hr before cable on's  
(all revised data)



Dogfish  
During 1hr cable on's  
(all revised data)



Dogfish  
1hr after cable on's  
(all revised data)



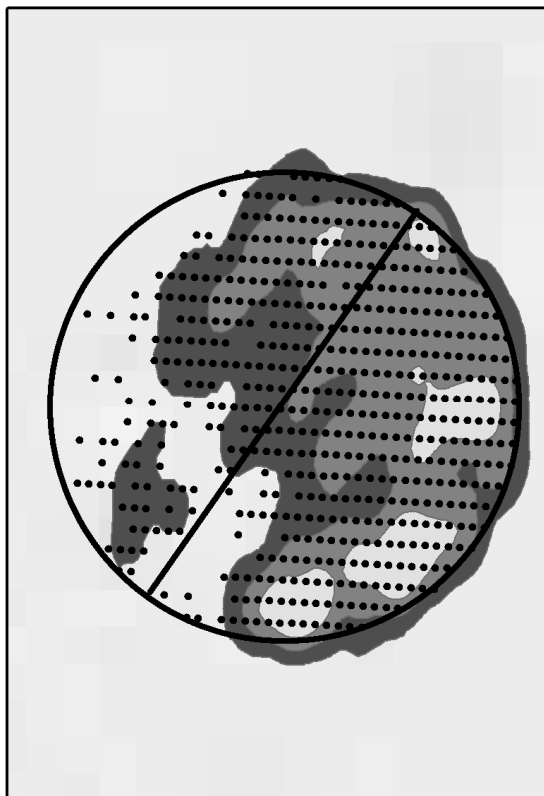
**Trial 2**  
**Overview of spatial distribution in 'Control' Mesocosm**

Study species:- Dogfish (*S.canicula*)

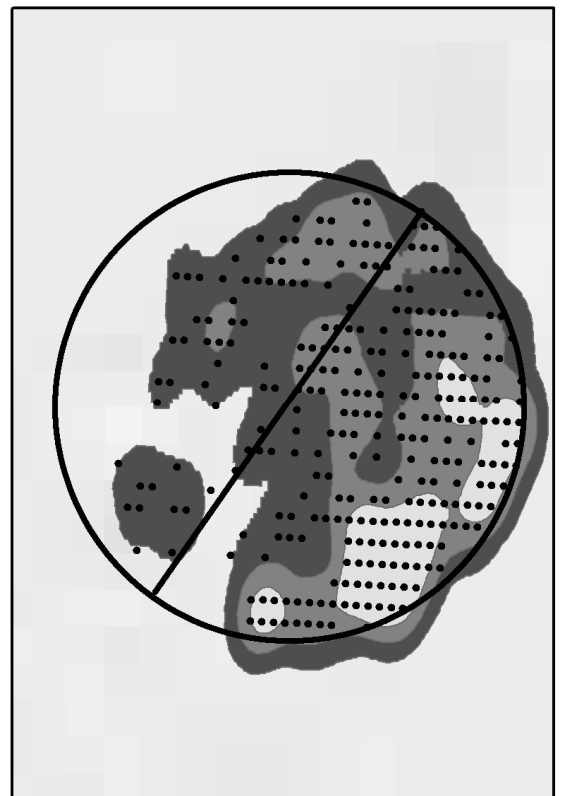
Study period:- Daylight looking at total of 19 events (cable switch on's)

(Event No's:- 1, 3, 5, 7, 9, 11, 13, 17, 19, 21, 22, 23, 25, 29, 31, 33, 35, 37)

Dogfish during day with cable off  
(all revised data)



Dogfish during day with cable on  
(all revised data)



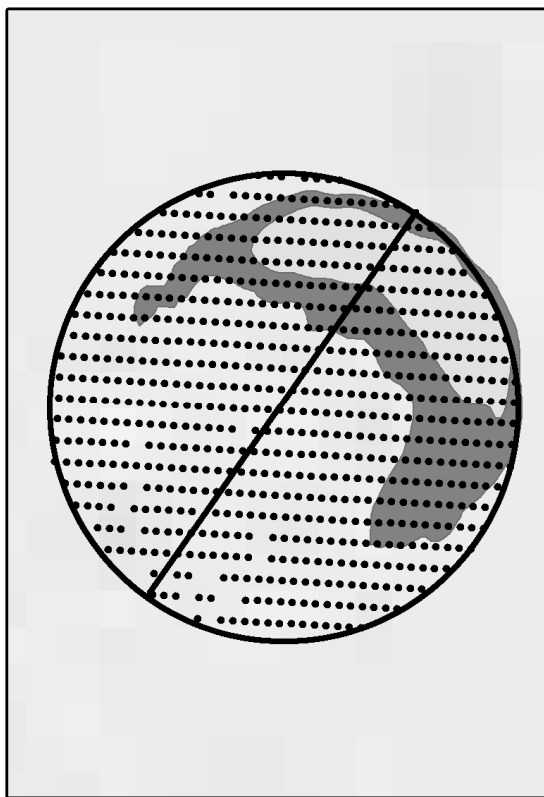
KPDF shading shows the probability density surfaces for 95% (dark grey), 75% (mid grey) and 50% (white)

**Trial 2**  
**Overview of spatial distribution in 'Control' Mesocosm**

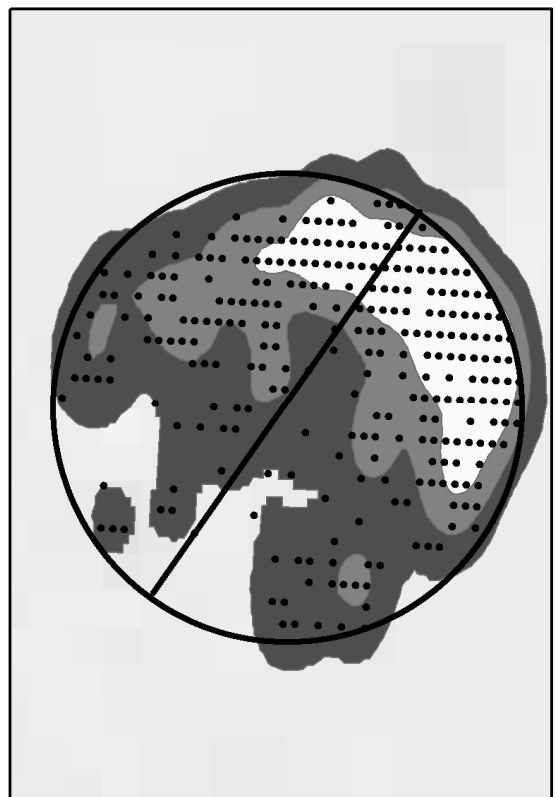
Study species:- Dogfish (*S.canicula*)

Study period:- Night time looking at total of 15 events (cable switch on's)  
(Event No's:- 2, 4, 8, 10, 12, 14, 18, 20, 24, 26, 30, 32, 34, 36, 38)

Dogfish during night with cable off  
(all revised data)



Dogfish during night with cable on  
(all revised data)



KPDF shading shows the probability density surfaces for 95% (dark grey), 75% (mid grey) and 50% (white)

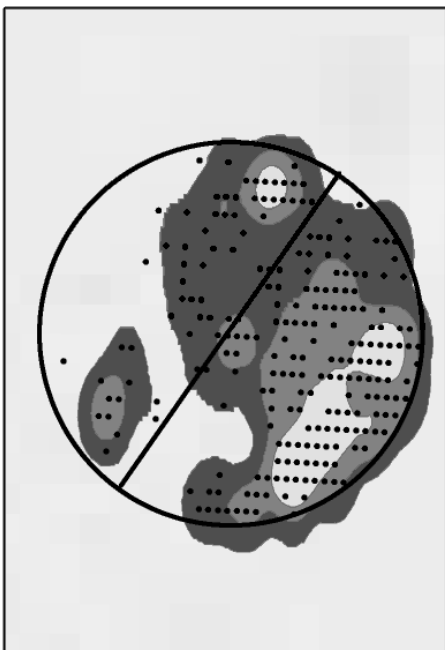
**Trial 2**  
**Detailed spatial distribution in 'Control' Mesocosm**  
**(1hr before, during and after cable switch on's)**

Study species:- Dogfish (*S.canicula*)

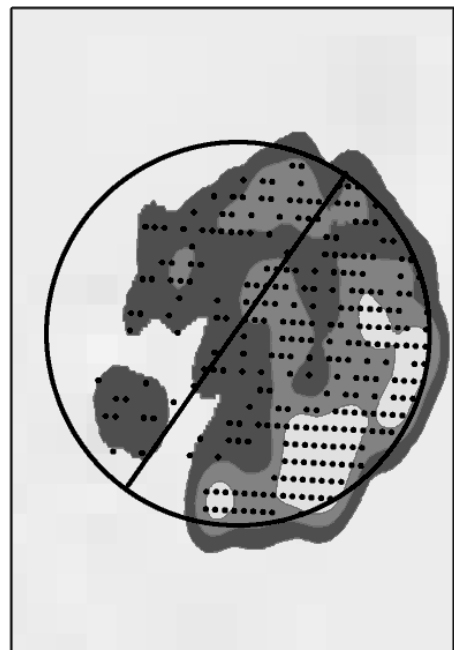
Study period:- Daylight looking at total of 19 events (cable switch on's)

(Event No's:- 1, 3, 5, 7, 9, 11, 13, 17, 19, 21, 22, 23, 25, 29, 31, 33, 35, 37)

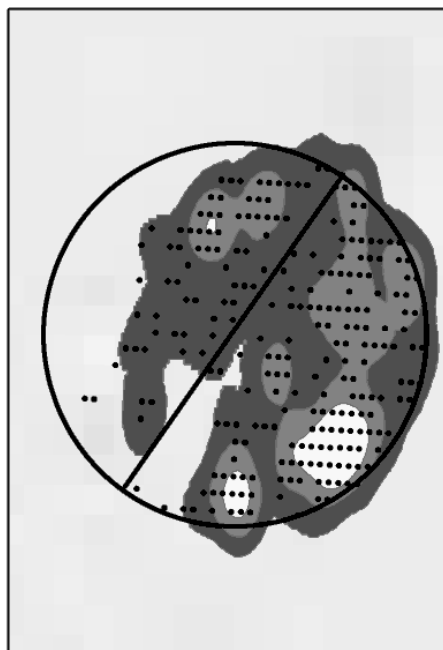
Dogfish  
Day 1hr before cable on's  
(all revised data)



Dogfish  
During 1hr cable on's  
(all revised data)



Dogfish  
1hr after cable on's  
(all revised data)





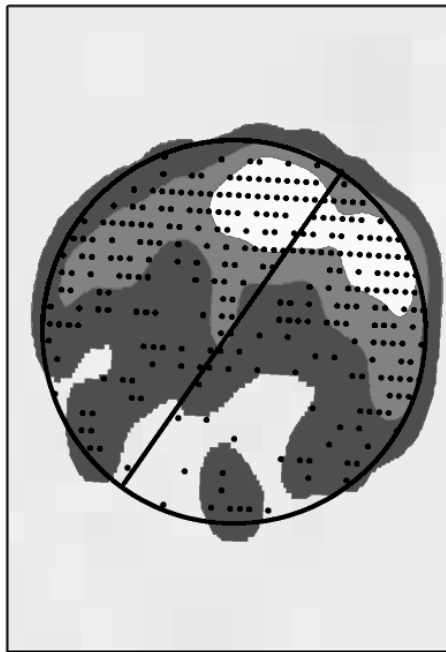
**Trial 2**  
**Detailed spatial distribution in 'Control' Mesocosm**  
**(1hr before, during and after cable switch on's)**

Study species:- Dogfish (*S.canicula*)

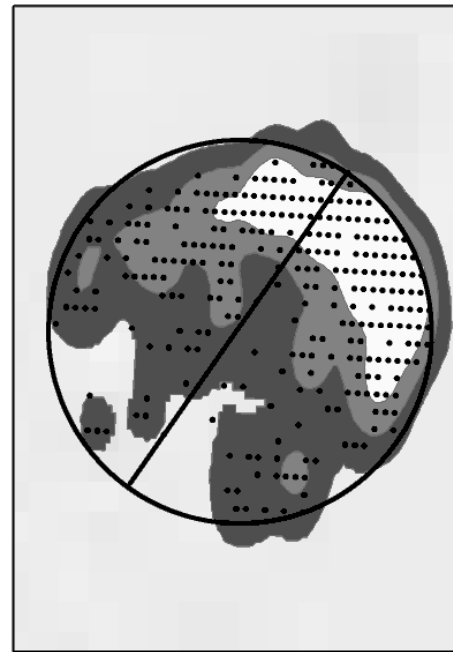
Study period:- Night time looking at total of 15 events (cable switch on's)

(Event No's:- 2, 4, 8, 10, 12, 14, 18, 20, 24, 26, 30, 32, 34, 36, 38)

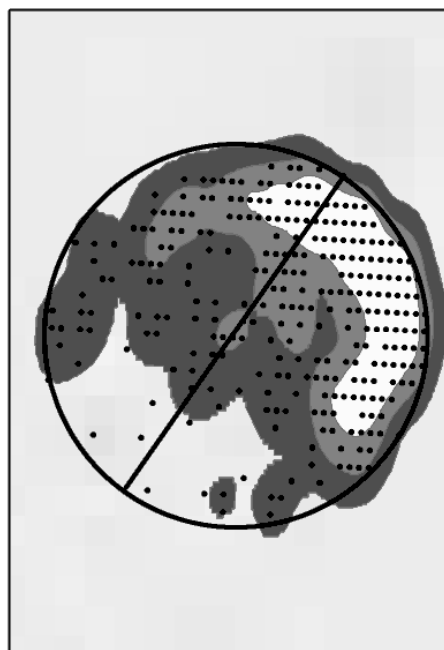
Dogfish  
Night 1hr before cable on's  
(all revised data)



Dogfish  
During 1hr cable on's  
(all revised data)



Dogfish  
1hr after cable on's  
(all revised data)



**Trial 2**  
**Detailed spatial distribution in 'Live' Mesocosm**  
**Before and after study period**

Study species:- Dogfish (*S.canicula*)

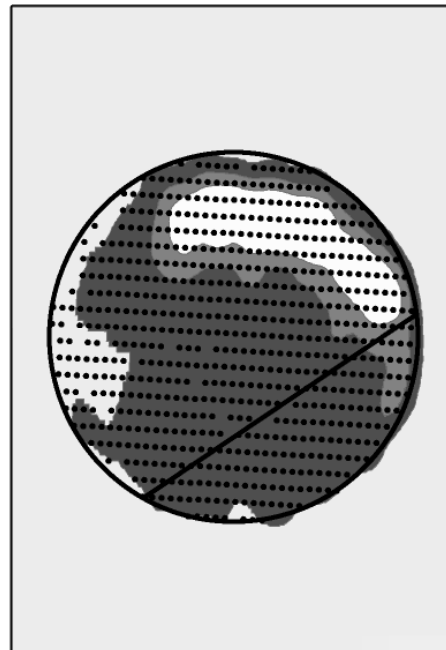
Study period:- Before trial:- 03/10/2007 – 15/10/2007

After trial:- 04/11/2007 – 19/11/2007

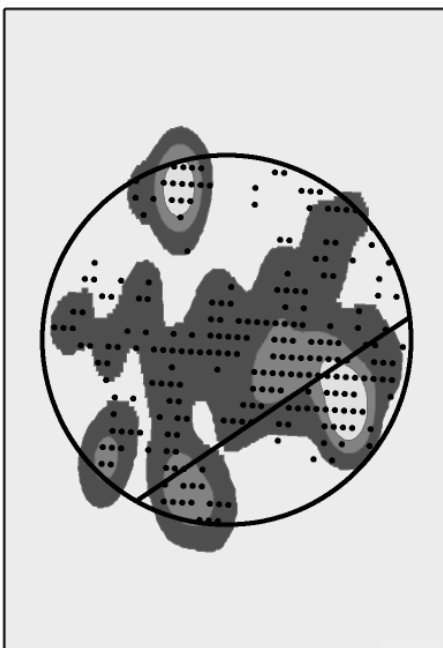
Dogfish  
Daylight before trial



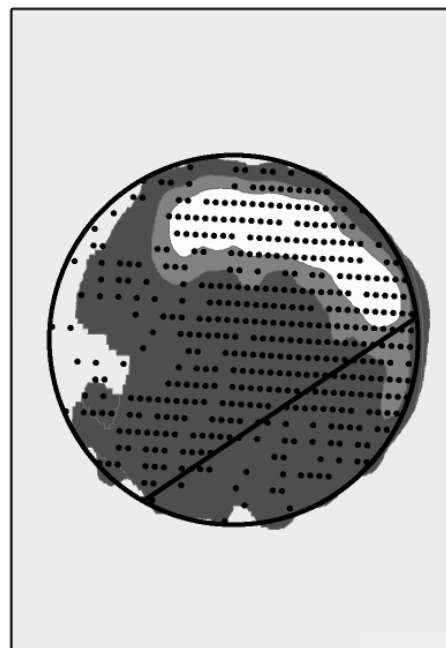
Dogfish  
Night before trial



Dogfish  
Daylight after trial



Dogfish  
Night after trial

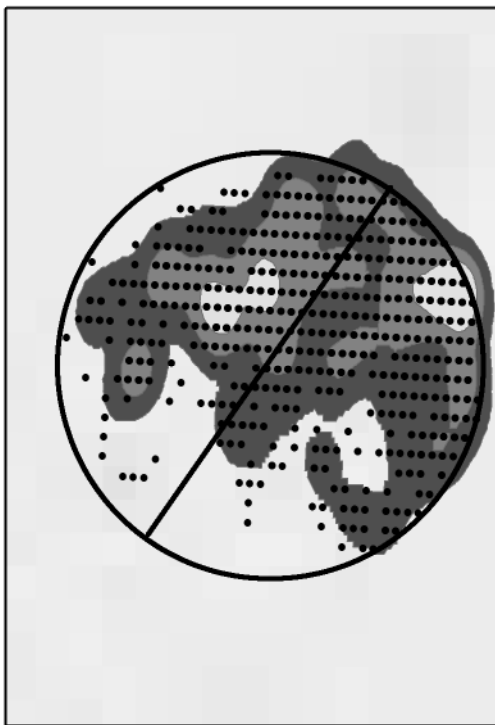


**Trial 3**  
**Overview of spatial distribution in 'Live' Mesocosm**

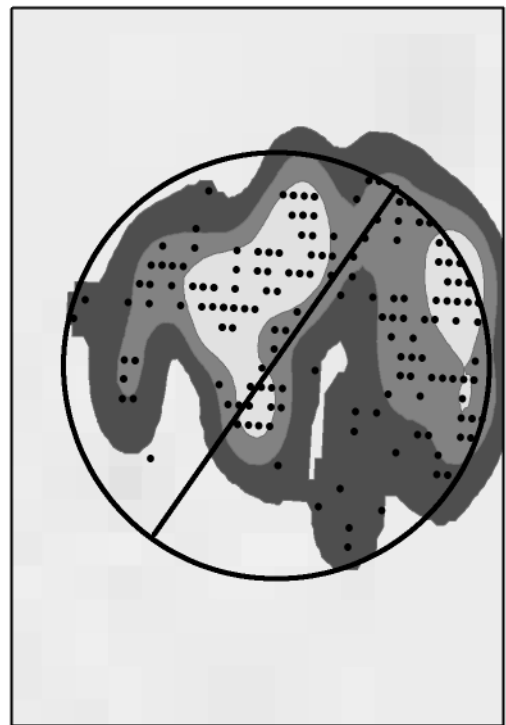
Study species:- Rays (*R. clavata*)

Study period:- Daylight looking at total of 13 events (cable switch on's)  
(Event No's:- 1, 3, 5, 7, 13, 15, 19, 21, 23, 27, 29, 31, 33)

Rays during day with cable off  
(all revised data)



Rays during day with cable on  
(all revised data)



KPDF shading shows the probability density surfaces for 95% (dark grey), 75% (mid grey) and 50% (white)

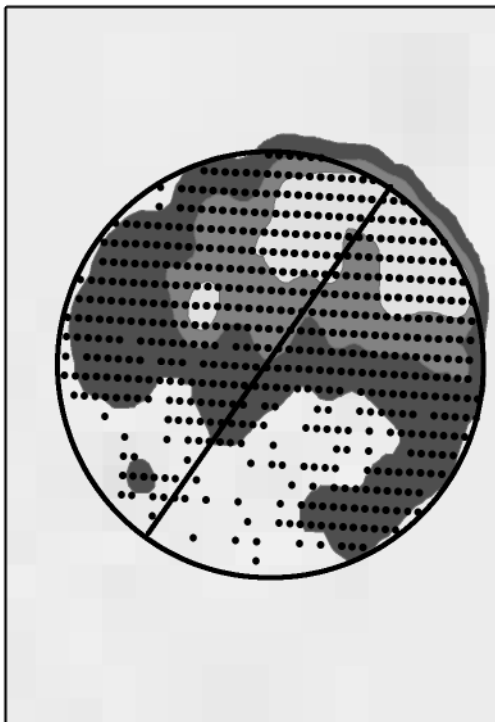
**Trial 3**  
**Overview of spatial distribution in 'Live' Mesocosm**

Study species:- Rays (*R. clavata*)

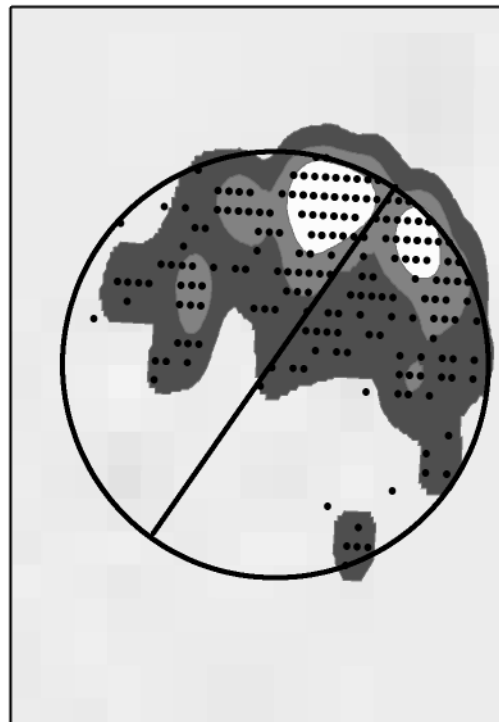
Study period:- Night time looking at total of 14 events (cable switch on's)

(Event No's:- 2, 4, 6, 12, 14, 16, 18, 20, 22, 24, 28, 30, 32, 34)

Rays during night with cable off  
(all revised data)



Rays during night with cable on  
(all revised data)



KPDF shading shows the probability density surfaces for 95% (dark grey), 75% (mid grey) and 50% (white)

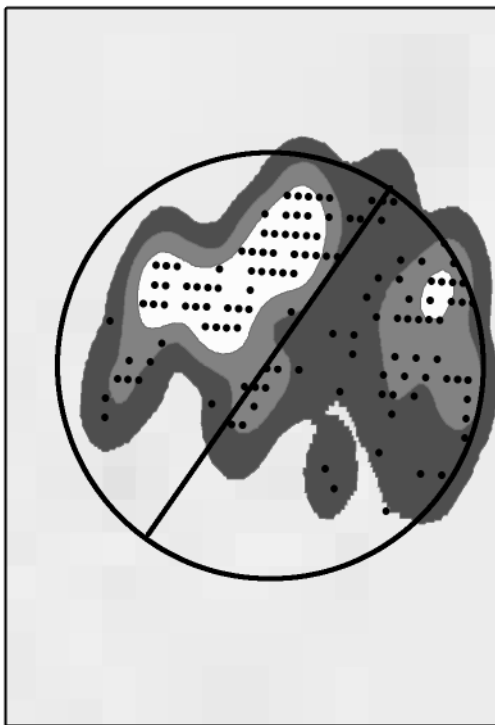
**Trial 3**  
**Detailed spatial distribution in 'Live' Mesocosm**  
**(1hr before, during and after cable switch on's)**

Study species:- Rays (*R.clavata*)

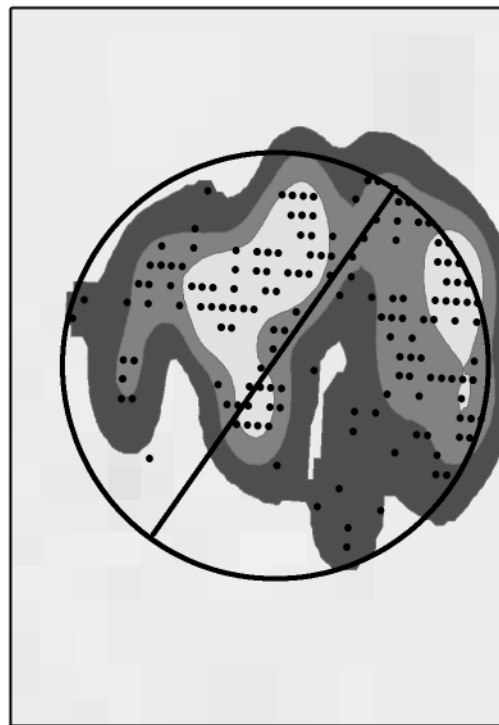
Study period:- Daylight looking at total of 13 events (cable switch on's)

(Event No's:- 1, 3, 5, 7, 13, 15,19, 21, 23, 27, 29, 31, 33)

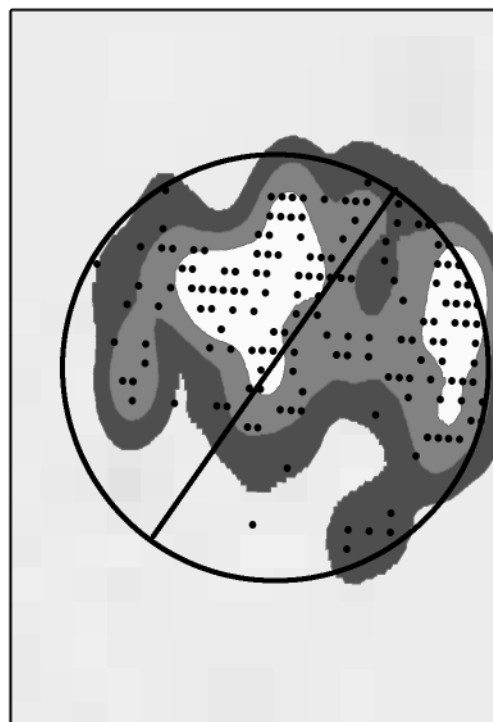
Rays  
Day 1hr before cable on's  
(all revised data)



Rays  
During 1hr cable on's  
(all revised data)



Rays  
1hr after cable on's  
(all revised data)



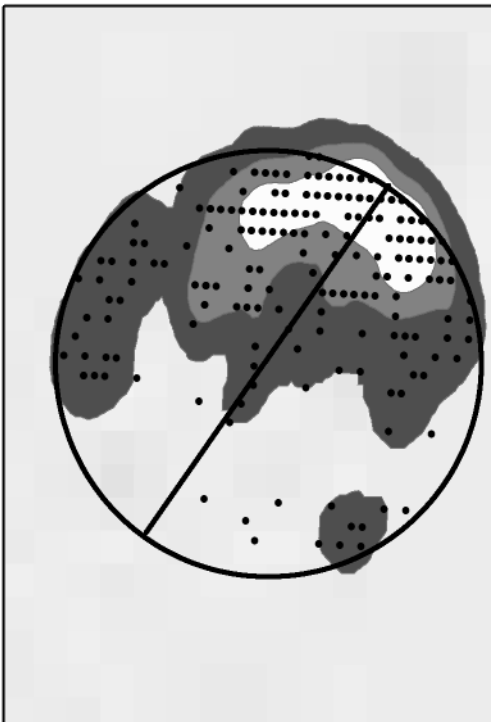
**Trial 3**  
**Detailed spatial distribution in 'Live' Mesocosm**  
**(1hr before, during and after cable switch on's)**

Study species:- Rays (*R.clavata*)

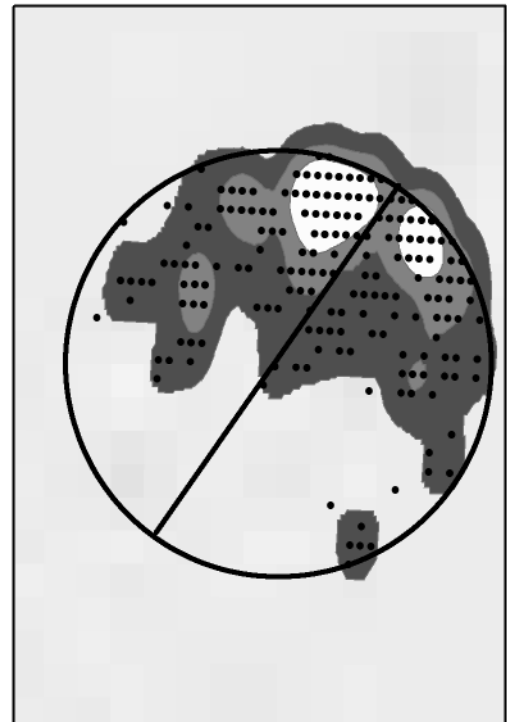
Study period:- Night time looking at total of 14 events (cable switch on's)

(Event No's:- 2, 4, 6, 12, 14, 16, 18, 20, 22, 24, 28, 30, 32, 34)

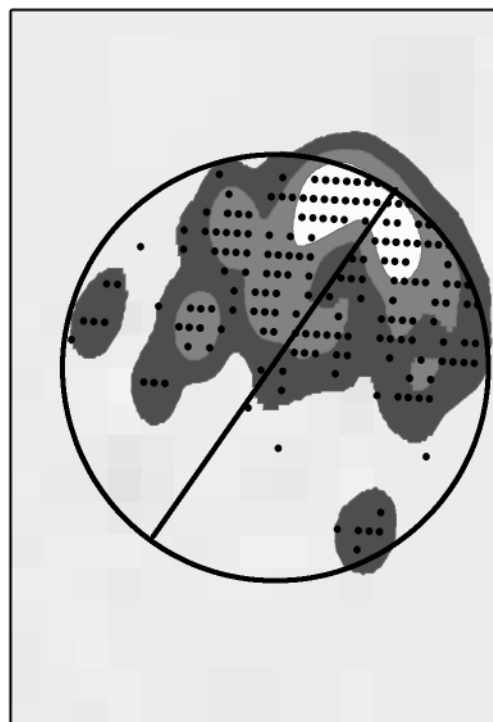
Rays  
Night 1hr before cable on's  
(all revised data)



Rays  
During 1hr cable on's  
(all revised data)



Rays  
1hr after cable on's  
(all revised data)

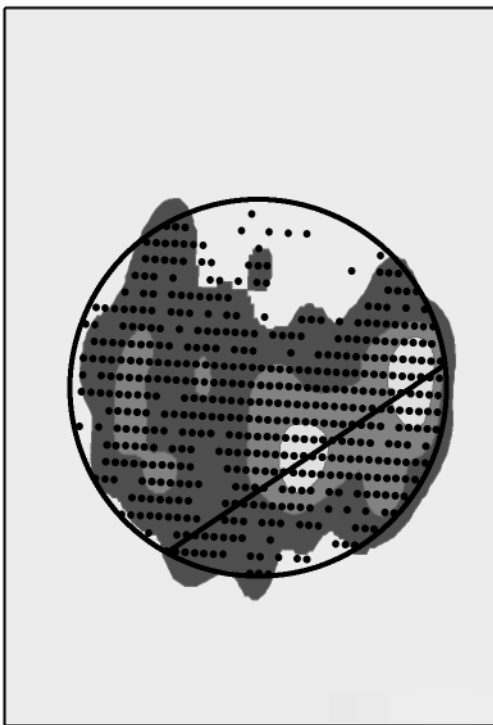


**Trial 3**  
**Overview of spatial distribution in 'Control' Mesocosm**

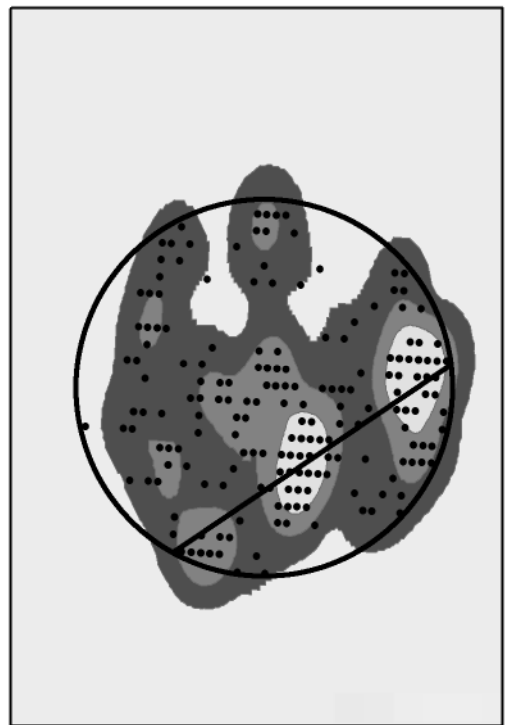
Study species:- Rays (*R. clavata*)

Study period:- Daylight looking at total of 13 events (cable switch on's)  
(Event No's:- 1, 3, 5, 7, 13, 15,19, 21, 23, 27, 29, 31, 33)

Rays during day with cable off  
(all revised data)



Rays during day with cable on  
(all revised data)



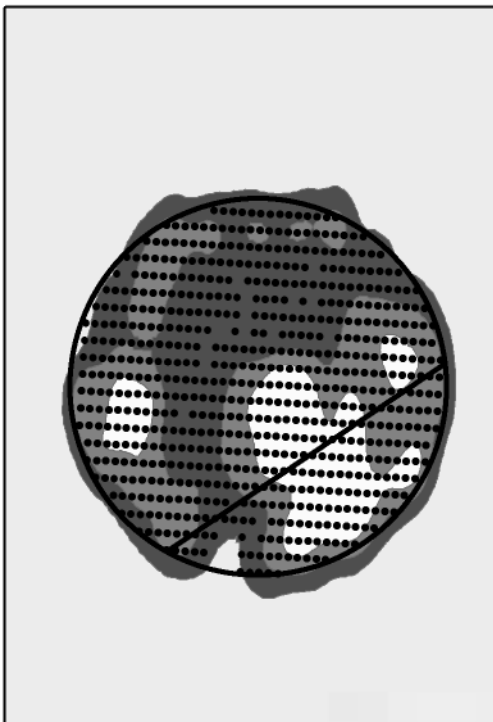
KPDF shading shows the probability density surfaces for 95% (dark grey), 75% (mid grey) and 50% (white)

**Trial 3**  
**Overview of spatial distribution in 'Control' Mesocosm**

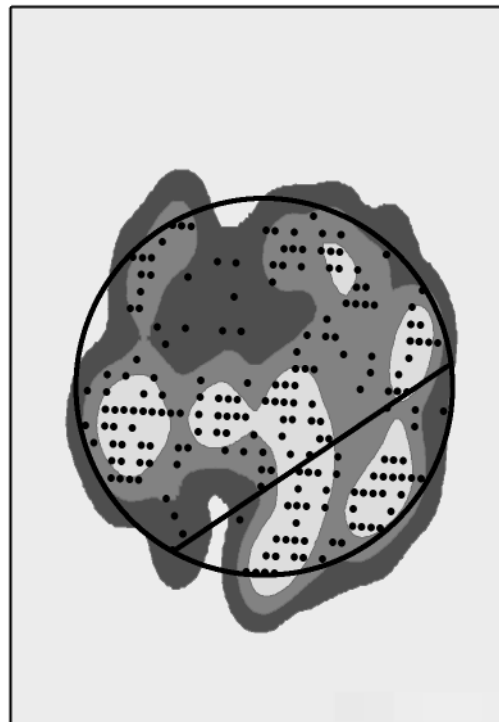
Study species:- Rays (*R. clavata*)

Study period:- Night time looking at total of 14 events (cable switch on's)  
(Event No's:- 2, 4, 6, 12, 14, 16, 18, 20, 22, 24, 28, 30, 32, 34)

Rays during night with cable off  
(all revised data)



Rays during night with cable on  
(all revised data)



KPDF shading shows the probability density surfaces for 95% (dark grey), 75% (mid grey) and 50% (white)

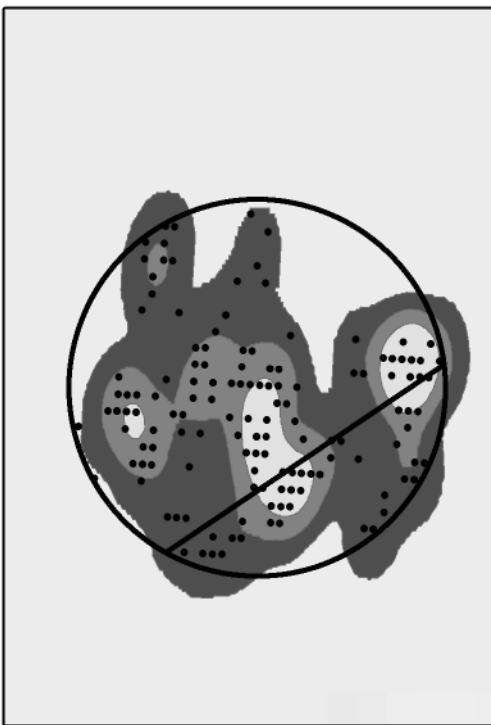


**Trial 3**  
**Detailed spatial distribution in 'Control' Mesocosm**  
**(1hr before, during and after cable switch on's)**

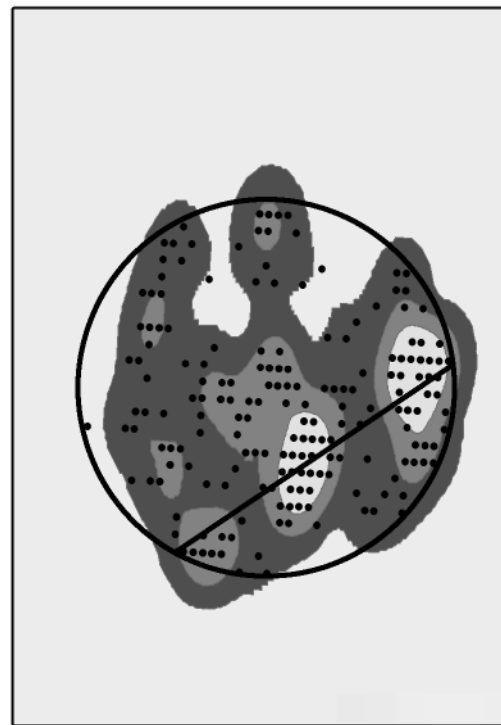
Study species:- Rays (*R.clavata*)

Study period:- Daylight looking at total of 13 events (cable switch on's)  
(Event No's:- 1, 3, 5, 7, 13, 15,19, 21, 23, 27, 29, 31, 33)

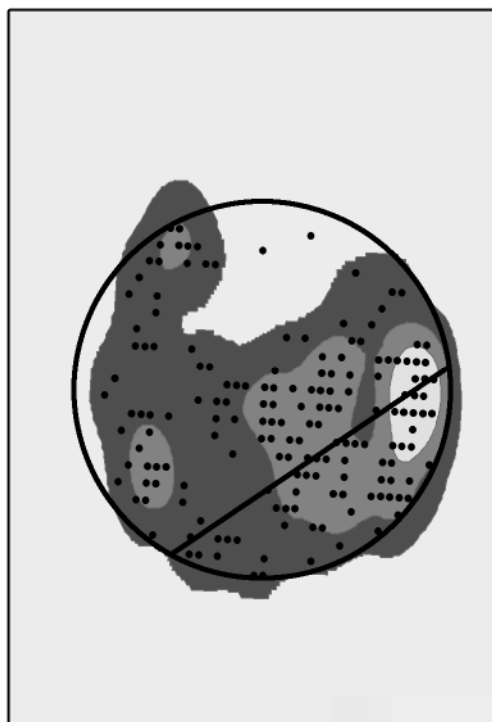
Rays  
Day 1hr before cable on's  
(all revised data)



Rays  
During 1hr cable on's  
(all revised data)



Rays  
1hr after cable on's  
(all revised data)



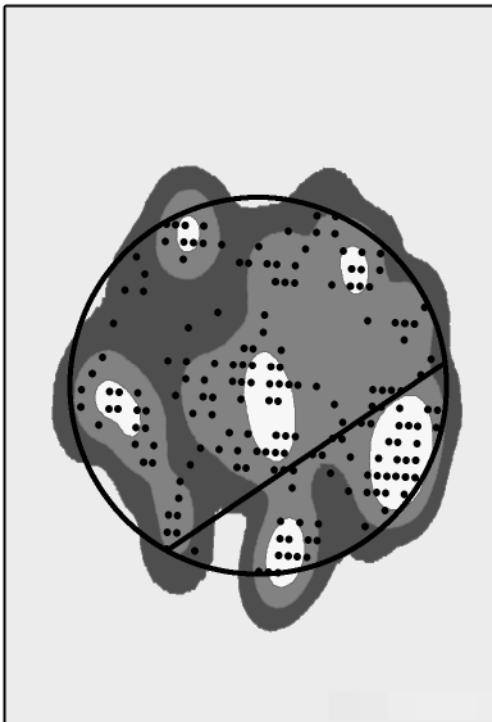
**Trial 3**  
**Detailed spatial distribution in 'Control' Mesocosm**  
**(1hr before, during and after cable switch on's)**

Study species:- Rays (*R.clavata*)

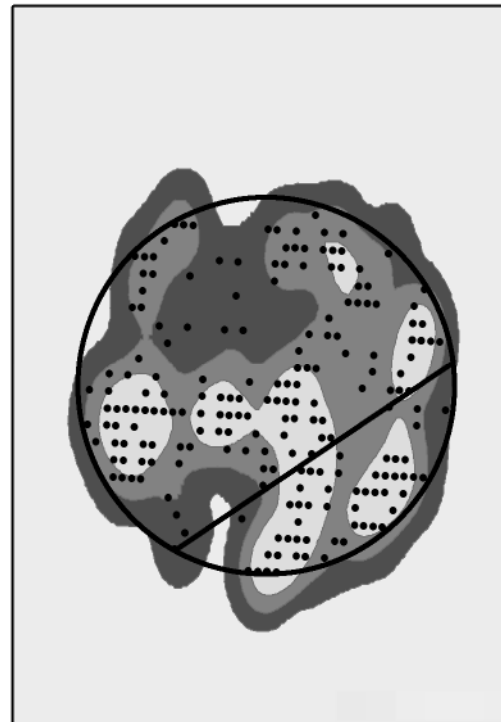
Study period:- Night time looking at total of 14 events (cable switch on's)

(Event No's:- 2, 4, 6, 12, 14, 16, 18, 20, 22, 24, 28, 30, 32, 34)

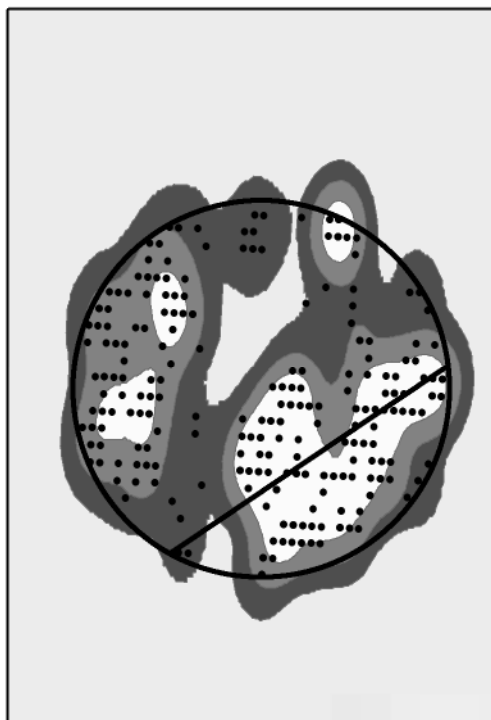
Rays  
Night 1hr before cable on's  
(all revised data)



Rays  
During 1hr cable on's  
(all revised data)



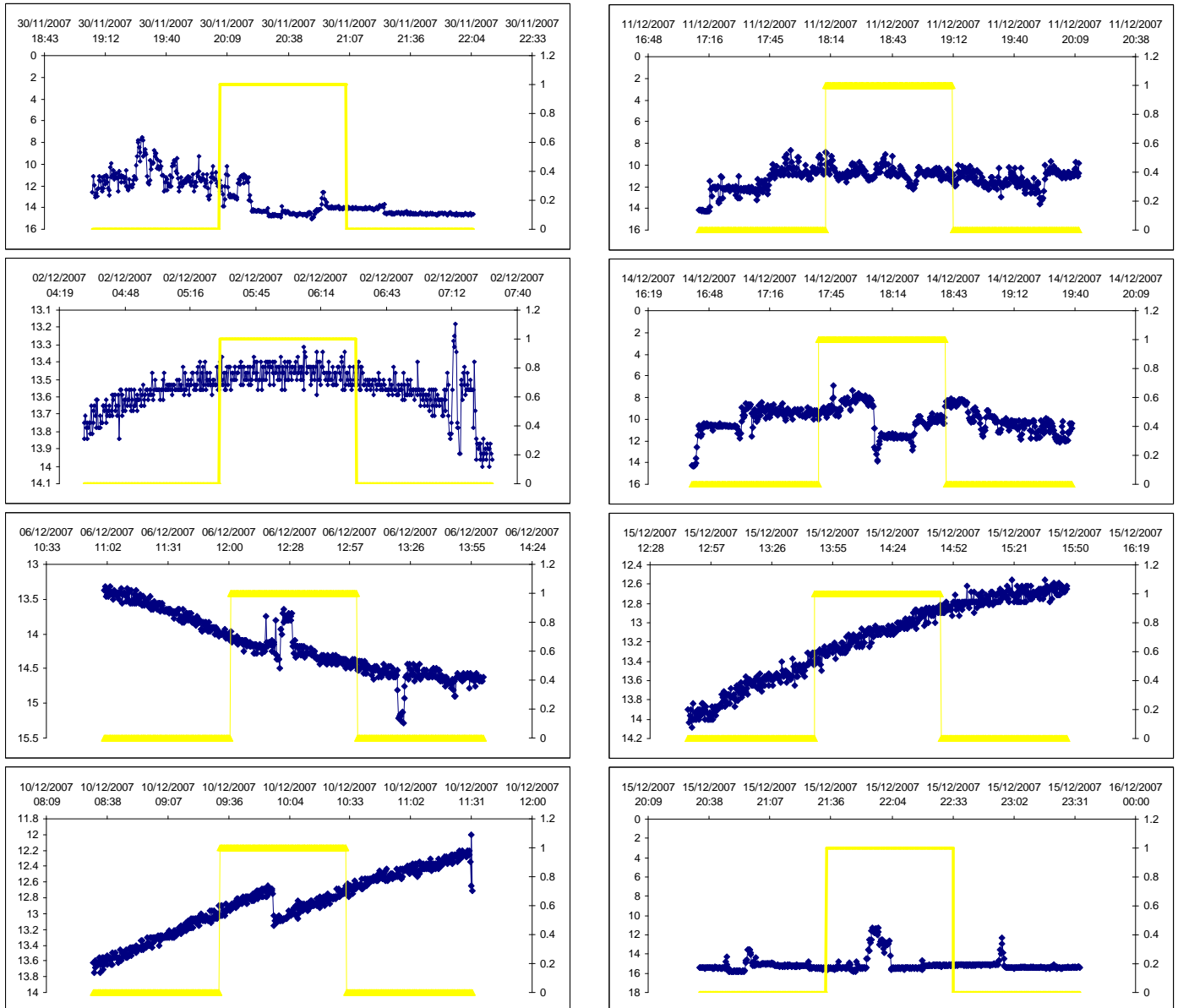
Rays  
1hr after cable on's  
(all revised data)



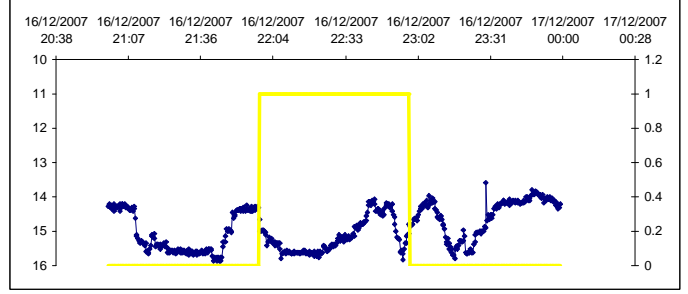
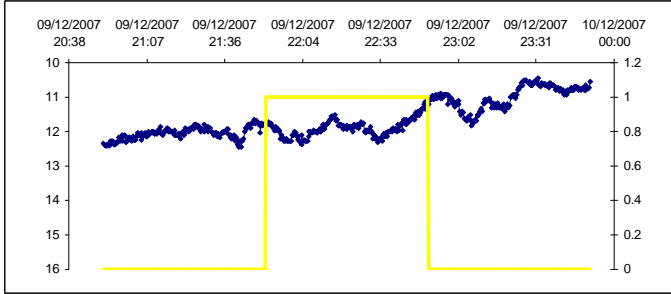
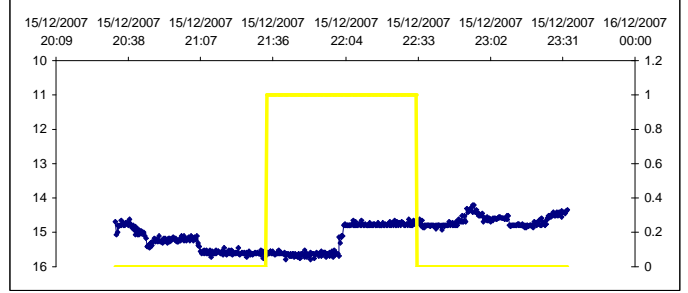
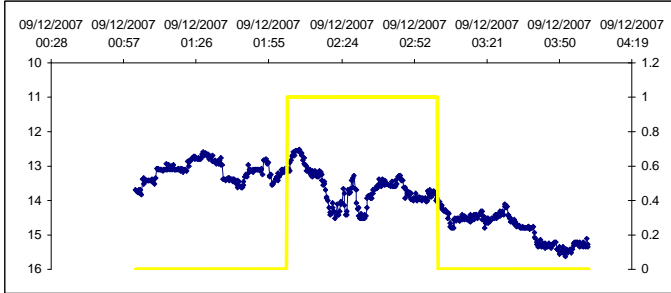
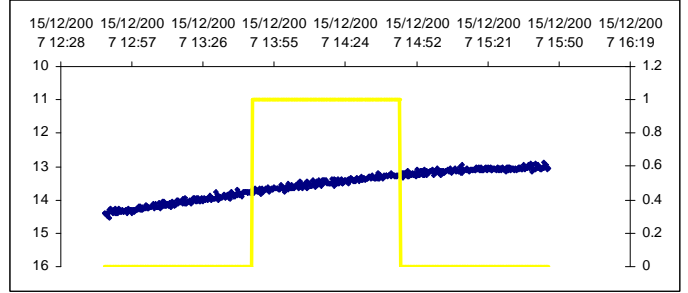
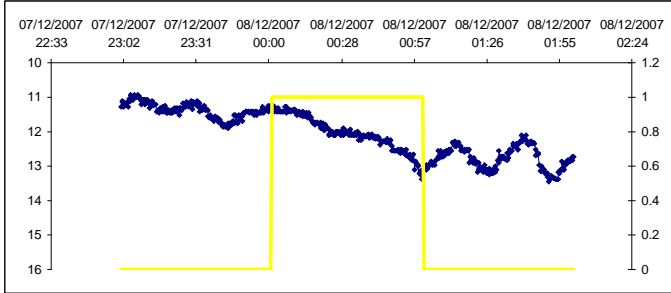
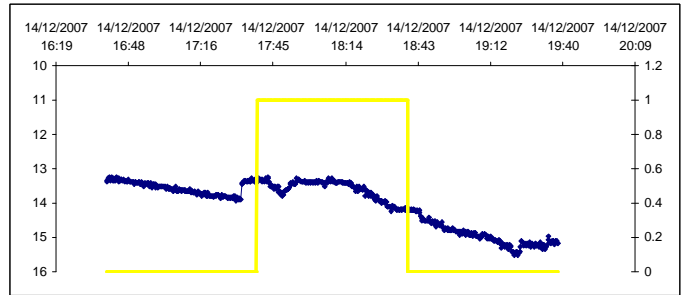
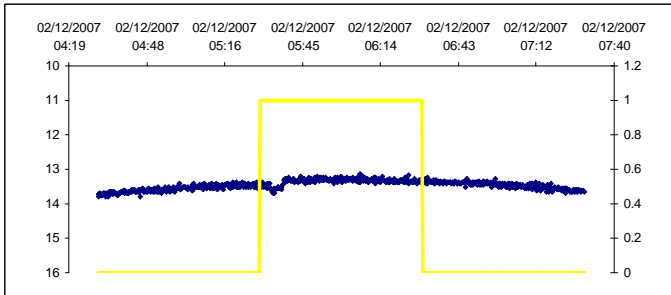
## Appendix 2. Data Storage Tag (DST) data.

Graphs show the depth (blue) in metres recorded through time for an individual fish on separate pages. The yellow line shows times when the electricity was being generated and emitting an EMF (0 = off; 1 = on). Note that some records do not show an EMF present as they occurred during times when we could not confirm that electricity was being generated. All available data are presented.

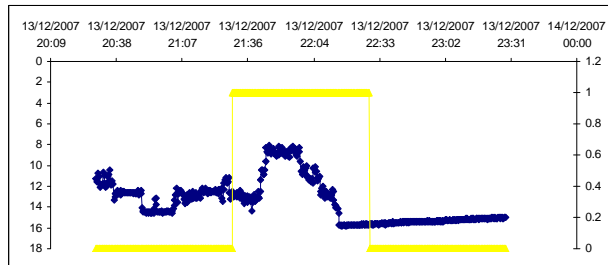
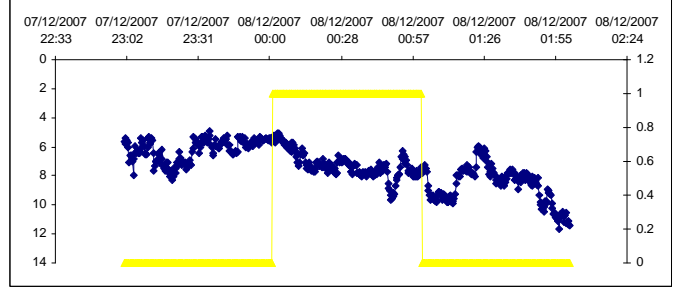
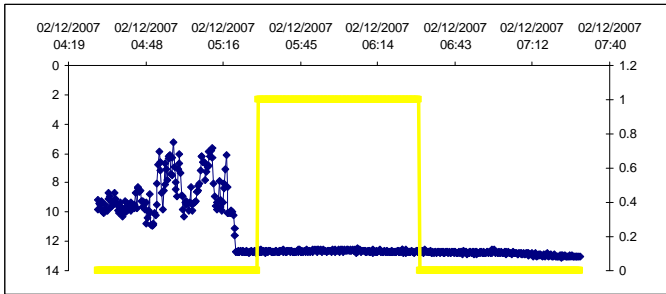
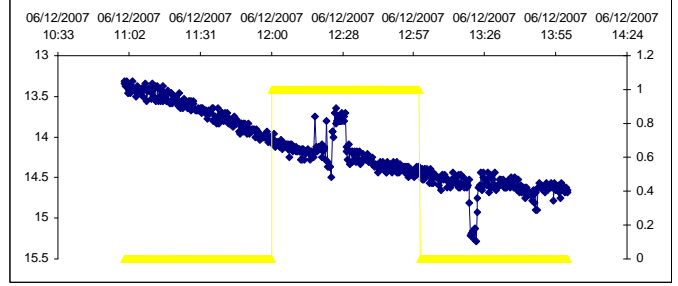
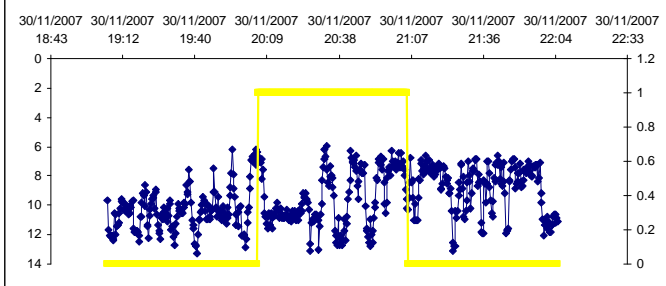
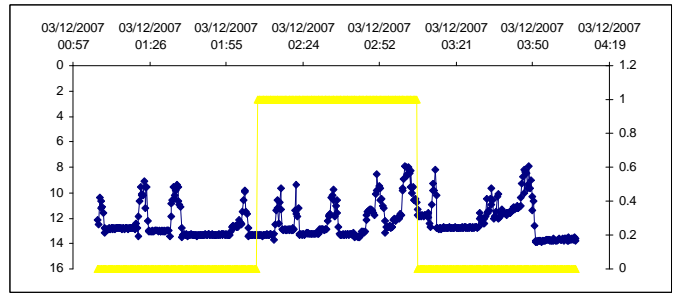
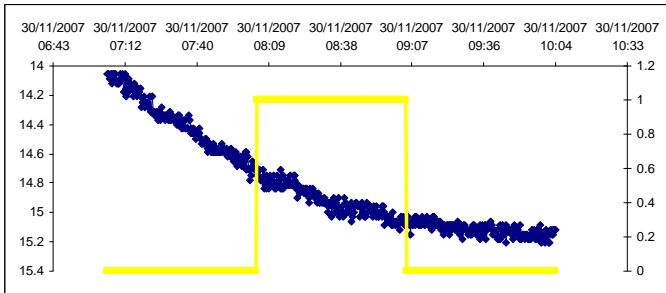
### Dogfish/Catshark (*S. canicula*) A00686 Trial 3



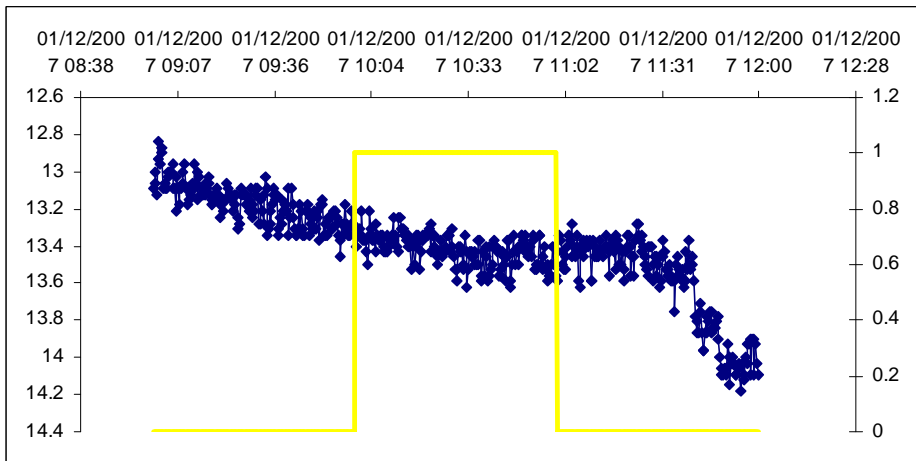
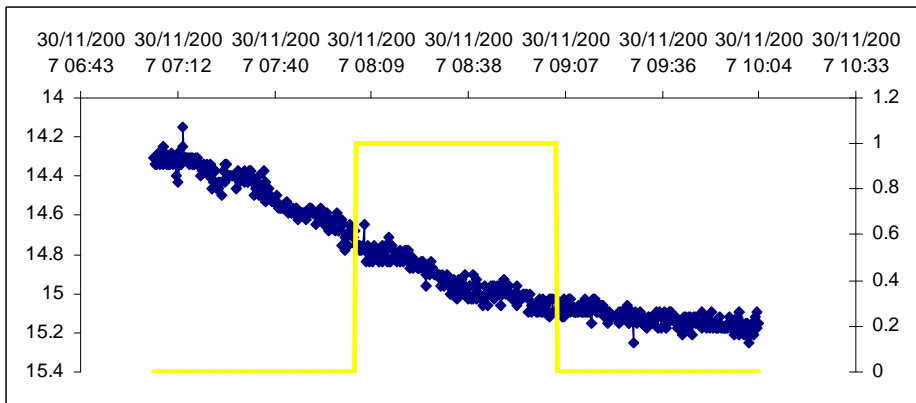
Ray (*R. clavata*) A00693 Trial 3



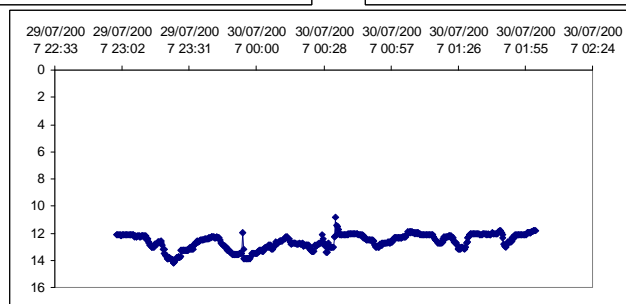
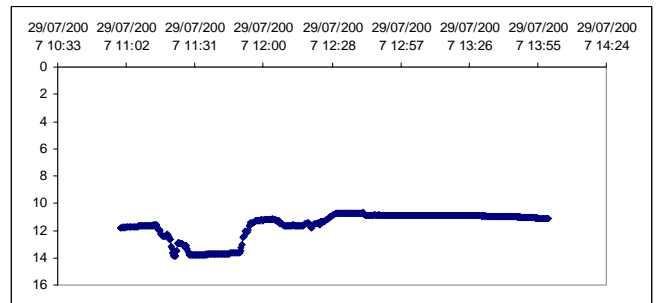
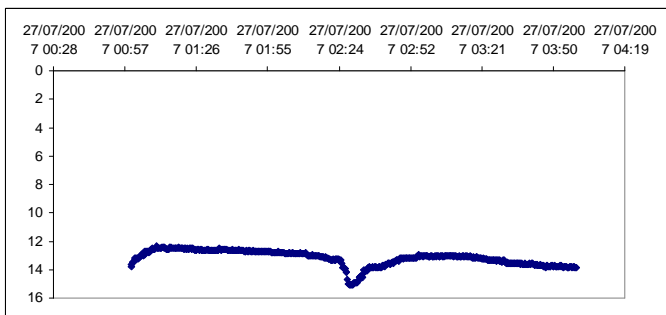
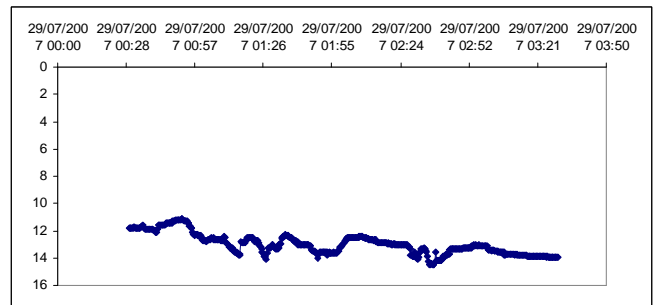
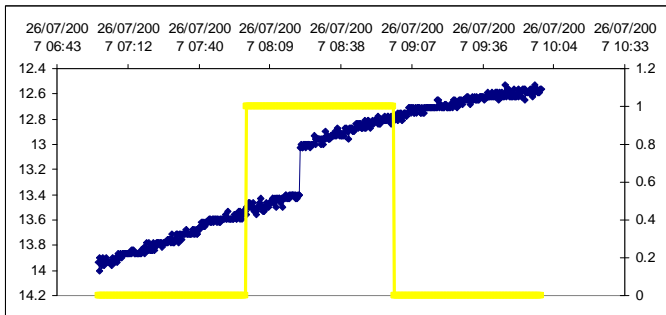
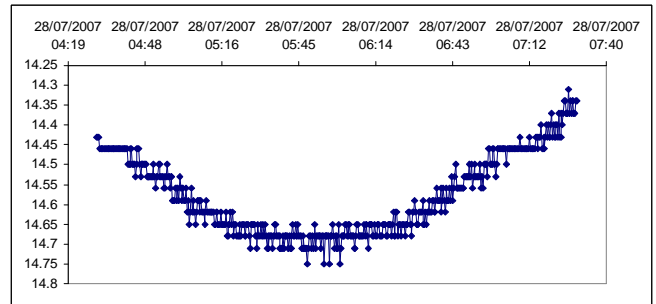
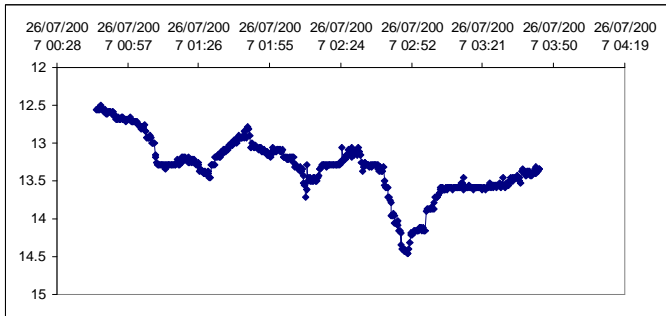
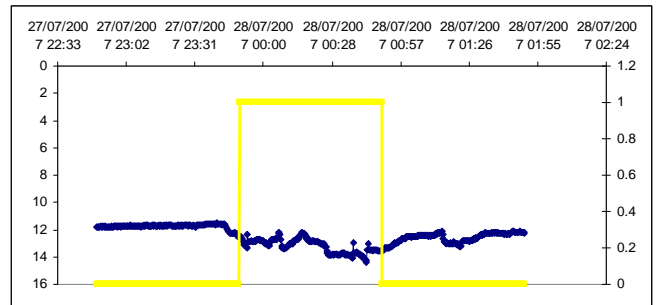
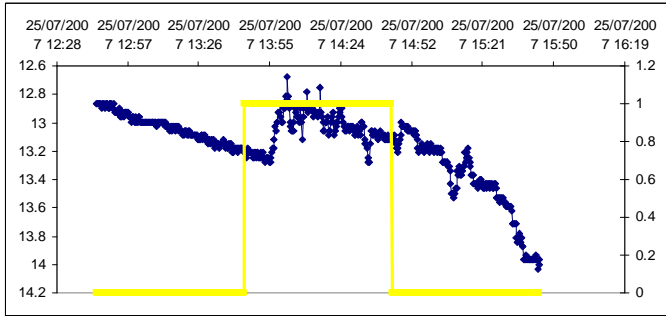
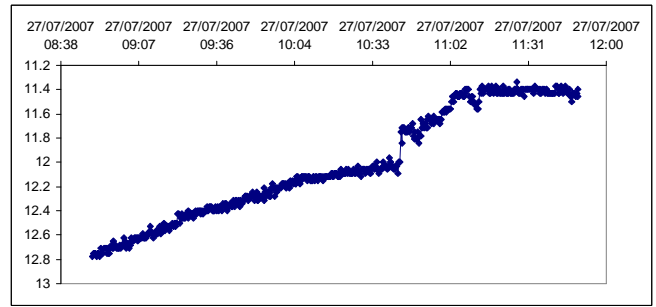
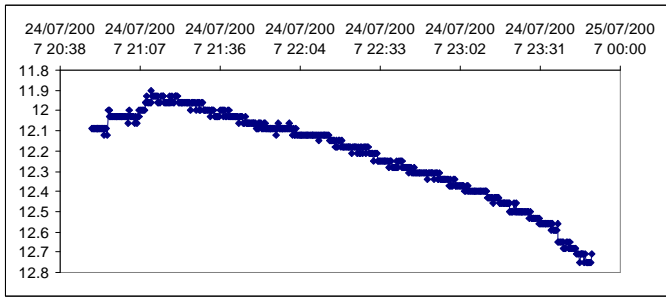
Dogfish/Catshark (*S. canicula*) A01163 Trial 3



Ray (*R. clavata*) A00880 Trial 3



# Ray (*R. clavata*) A00827 Trial 1



# COWRIE 2.0 EMF Study Ardtoe

