

WP4: Research to Innovate and Improve Infrastructures,
Technologies and Techniques

Deliverable 4.13

Report on field buoy research

Status: Final
Version: 05
Date: 24-Mar-2015



ABOUT MARINET

























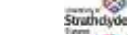

MARINET (Marine Renewables Infrastructure Network for emerging Energy Technologies) is an EC-funded network of research centres and organisations that are working together to accelerate the development of marine renewable energy - wave, tidal & offshore-wind. The initiative is funded through the EC's Seventh Framework Programme (FP7) and runs for four years until 2015. The network of 29 partners with 42 specialist marine research facilities is spread across 11 EU countries and one International Cooperation Partner Country (Brazil).

MARINET offers periods of free-of-charge access to test facilities at a range of world-class research centres. Companies and research groups can avail this Transnational Access (TA) to test devices at any scale in areas such as wave energy, tidal energy, offshore-wind energy and environmental data or to conduct tests on cross-cutting areas such as power take-off systems, grid integration, materials or moorings. In total, over 700 weeks of access is available to estimated 300 projects and 800 external users, with at least four calls for access applications over the 4-year initiative.

MARINET partners are also working to implement common standards for testing in order to streamline the development process, conducting research to improve testing capabilities across the network, providing training at various facilities in the network in order to enhance personnel expertise and organising industry networking events to facilitate partnerships and knowledge exchange.

The initiative consists of five main Work Package focus areas: Management & Administration, Standardisation & Best Practice, Transnational Access & Networking, Research, Training & Dissemination. The aim is to streamline the capabilities of test infrastructures in order to enhance their impact and accelerate the commercialisation of marine renewable energy. See www.fp7-marinet.eu for more details.

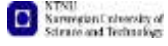
Partners

  	<p>Ireland University College Cork, HMRC (UCC_HMRC) <i>Coordinator</i> Sustainable Energy Authority of Ireland (SEAI_OEDU)</p>	<p>Netherlands Stichting Tidal Testing Centre (TTC) Stichting Energieonderzoek Centrum Nederland (ECNeth)</p>	 
 	<p>Denmark Aalborg Universitet (AAU) Danmarks Tekniske Universitet (RISOE)</p>	<p>Germany Fraunhofer-Gesellschaft Zur Foerderung der angewandten Forschung E.V (Fh_IWES) Gottfried Wilhelm Leibniz Universität Hannover (LUH) Universitaet Stuttgart (USTUTT)</p>	  
	<p>France Ecole Centrale de Nantes (ECN) Institut Français de Recherche Pour l'Exploitation de la Mer (IFREMER)</p>	<p>Portugal Wave Energy Centre – Centro de Energia das Ondas (WavEC)</p>	
      	<p>United Kingdom National Renewable Energy Centre Ltd. (NAREC) The University of Exeter (UNEXE) European Marine Energy Centre Ltd. (EMEC) University of Strathclyde (UNI_STRATH) The University of Edinburgh (UEDIN) Queen's University Belfast (QUB) Plymouth University (PU)</p>	<p>Italy Università degli Studi di Firenze (UNIFI-CRIACIV) Università degli Studi di Firenze (UNIFI-PIN) Università degli Studi della Tuscia (UNI_TUS) Consiglio Nazionale delle Ricerche (CNR-INSEAN)</p>	   
 	<p>Spain Ente Vasco de la Energía (EVE) Tecnalia Research & Innovation Foundation (TECNALIA)</p>	<p>Norway Sintef Energi AS (SINTEF) Norges Teknisk-Naturvitenskapelige Universitet (NTNU)</p>	 
	<p>Belgium 1-Tech (1_TECH)</p>		

DOCUMENT INFORMATION

Title	Report on field buoy research			
Distribution	[Choose distribution authorisation]			
Document Reference	MARINET-D4.13			
Deliverable Leader	Dr Lars Johanning	UNEXE	Violette Harnois	UNEXE
Contributing Authors	Andrea Bauer; Fh_IWES			

REVISION HISTORY

Rev.	Date	Description	Prepared by (Name & Org.)	Approved By (Task/Work- Package Leader)	Status (Draft/Final)
01	26/09/2013	Report on field buoy research	Violette Harnois; UNEXE	No	DRAFT
02	12/11/2013	Report on field buoy research	Lars Johanning; UNEXE	Yes	FINAL DRAFT
03	19/03/2015	Review	Andrea Bauer; Fh_IWES		FINAL DRAFT
04	22/03/2015	Review	Claudia Rudolph; Fh_IWES		FINAL DRAFT
05	24/03/2015	Corrections	Violette Harnois; UNEXE		FINAL DRAFT
06	24/03/2015	Approved	Lars Johanning UNEXE	Yes	FINAL

ACKNOWLEDGEMENT

The work described in this publication has received support from the European Community - Research Infrastructure Action under the FP7 “Capacities” Specific Programme through grant agreement number 262552, MaRINET.

LEGAL DISCLAIMER

The views expressed, and responsibility for the content of this publication, lie solely with the authors. The European Commission is not liable for any use that may be made of the information contained herein. This work may rely on data from sources external to the MARINET project Consortium. Members of the Consortium do not accept liability for loss or damage suffered by any third party as a result of errors or inaccuracies in such data. The information in this document is provided “as is” and no guarantee or warranty is given that the information is fit for any particular purpose. The user thereof uses the information at its sole risk and neither the European Commission nor any member of the MARINET Consortium is liable for any use that may be made of the information.

EXECUTIVE SUMMARY

This report constitutes deliverable WP4.D13 as part of MARINET project. The aim of this report is to provide a summary of the field buoy research at the South West Mooring Test Facility (SWMTF).

The initial section gives an overview of the facility: location, environmental conditions and configuration: the floating structure, its mooring and the wave and current transducer.

The instrumentation and data collection is presented. This includes the equipment to measure environmental conditions, mooring loads, motion of the floating structure, and other equipment. The equipment and data collection are summarized in tables.

Some results are shown: time series and summary data of environmental data, mooring load and buoy motion. These results will be the base for further studies which aim to test new materials or configuration in real sea conditions, and to gain understanding of mooring system for Marine Renewable Energy (MRE) devices.

The principal outcome of this deliverable is a common information source for all MARINET partners about sea trials. Sea trials are a key point in the development process of a MRE device. They should be used to develop methodologies for installation and operation of MRE devices.

Associated publications:

V. Harnois; L. Johanning; P.R. Thies; I. Bjerke. The influence of environmental conditions on the extreme mooring loads for highly dynamic responding moored structures; in preparation

P.R. Thies; L. Johanning; V. Harnois; H.C. Smith; D.N. Parish. (2013) Mooring line fatigue damage evaluation for floating marine energy converters: Field measurements and prediction, Renewable Energy, volume 63, pages 133-144, DOI:10.1016/j.renene.2013.08.050.

HARNOIS, V., WELLER, S.D., JOHANNING, L., THIES, P.R., LE BOULLUEC, M., LE ROUX, D., SOULÉ, V., AND OHANA J.; (2014) Numerical model validation for mooring systems: Method and application for wave energy converters; Renewable Energy 75 (2015) 869-887, <http://dx.doi.org/10.1016/j.renene.2014.10.063>

P.R. THIES, L. JOHANNING; V. HARNOIS; H.C. SMITH; D.N. PARISH. (2013) Mooring line fatigue damage evaluation for floating marine energy converters: Field measurements and prediction, Renewable Energy, volume 63, pages 133-144, DOI: <http://dx.doi.org/10.1016/j.renene.2013.08.050>

V. HARNOIS, A. BOUFERROUK, B. STRONG AND L. JOHANNING; (2014) Practical considerations for the analysis of wave and current data from ADCP measurements during long term sea trials; 1st International Conference on Renewable Energies Offshore (RENEW 2014), 24 - 26 November 2014, Lisbon, Portugal

V. HARNOIS, L. JOHANNING, P.R. THIES; Wave Conditions Inducing Extreme Mooring Loads on a Dynamically Responding Moored Structure; 10th European Wave and Tidal Energy Conference (EWTEC 2013), 2-6 September 2013, Aalborg, Denmark

CONTENTS

1	INTRODUCTION	7
2	DESCRIPTION OF THE FACILITY	8
2.1	LOCATION	8
2.2	ENVIRONMENTAL CONDITIONS.....	9
2.3	BUOY	10
2.4	MOORING SYSTEM.....	11
2.5	ADCP.....	13
3	EQUIPMENT AND DATA COLLECTION.....	15
3.1	MEASUREMENT OF ENVIRONMENTAL CONDITIONS	15
3.2	TENSION IN THE MOORING LINES	16
3.3	MOTION OF THE FLOATING STRUCTURE	18
3.4	OTHER EQUIPMENT AND DATA.....	19
3.5	SUMMARY OF THE INSTRUMENTATION	20
3.6	SUMMARY OF THE OPERATIONS	21
4	FIELD MEASUREMENT.....	22
4.1	MARINE ENVIRONMENT DATA.....	22
4.2	MOORING LOAD.....	27
4.3	MOTION	28
5	RESEARCH FINDINGS.....	29
6	CONCLUSIONS AND RECOMMENDATIONS.....	30
7	REFERENCES	31

1 INTRODUCTION

A unique mooring load and response test facility is part of the MARINET network: the South Western Mooring Test Facility (SWMTF) has been built to conduct long term sea trials. This deliverable summarises the equipment and the collected data at this facility. Field tests are an important step to develop successful Marine Renewable Energy (MRE) technologies. They will help the various facilities and contribute to the development of a process from design to full scale deployment of a MRE device.

Section 2 is an introduction to the facility, and provides an overview of the deployment site and its environmental conditions, as well as the floating structure, mooring system and wave and current transducer which are used at the moment.

The equipment installed on the floating structure as well as the properties of the wave and current transducer are described in more detail in section 3. This section also summarises the operations which took place at the facility.

Some examples of the principal measurements are given in section 4: time series and summarised data over several days. Section 5 gives an example of use of these measurements in ongoing research.

This deliverable has an important role in Task 4.6, presenting a unique infrastructure used for station-keeping research. This infrastructure is used to gain information about operation and deployment of MRE devices, as well as to improve the understanding of mooring system, or to develop a relevant standard for MRE devices, which is part of the aims of Work Package 4 “Research to innovate and improve Infrastructures, technologies and techniques”.

2 DESCRIPTION OF THE FACILITY

A unique mooring load and response test facility has been built to conduct long term sea trials: the South Western Mooring Test Facility (SWMTF). This research is led by the mooring and hydrodynamic group at the University of Exeter, working with the Peninsula Research Institute for Marine Renewable Energy (PRIMaRE).

This facility has been designed to investigate structural response behaviour, mooring/umbilical behaviour and subsea components, and to develop suitable monitoring systems. It provides real sea conditions which allow comprehensive performance analysis of MRE mooring systems and their components. This facility is installed in Falmouth Bay, Cornwall, and hosts an instrumented system: a floating buoy and a compliant mooring system as well as an Acoustic Doppler Current Profiler (ADCP). Data have been recorded from September 2010.

This facility has been previously described by Harnois [1] and Johanning [2]. The results of this facility have also been used by Thies [3] for mooring line fatigue evaluation.

This section will provide an overview of the location of the facility, the environmental conditions at this location, the current floating structure and mooring system, and its wave and current transducer.

2.1 LOCATION

The South Western Mooring Test Facility (SWMTF) is installed in Falmouth Bay, Cornwall, UK (Figure 2.1). Falmouth Bay was chosen to provide a location near a port and with wave conditions with a 1/3rd scale to the Wave Hub site. Based on Froude scaling law this allows investigation suitable for a device with lengths a third of those used for a full scale device, whilst viscous effects are not directly scalable.

A 23 year hindcast SWAN [4] model ([5] and [6]) was developed to choose the deployment position from four possible locations. SWAN is a spectral wave model that computes the propagation of sea states in coastal regions. As an input to the SWAN model, data from November 2005 to October 2006 were provided by the UK Met Office at the boundaries of the site.

Based on this study, and after bathymetry investigation and mooring design, the exact location of deployment of the buoy has been chosen as $50^{\circ} 04.75''$ N, $05^{\circ} 02.85''$ W.

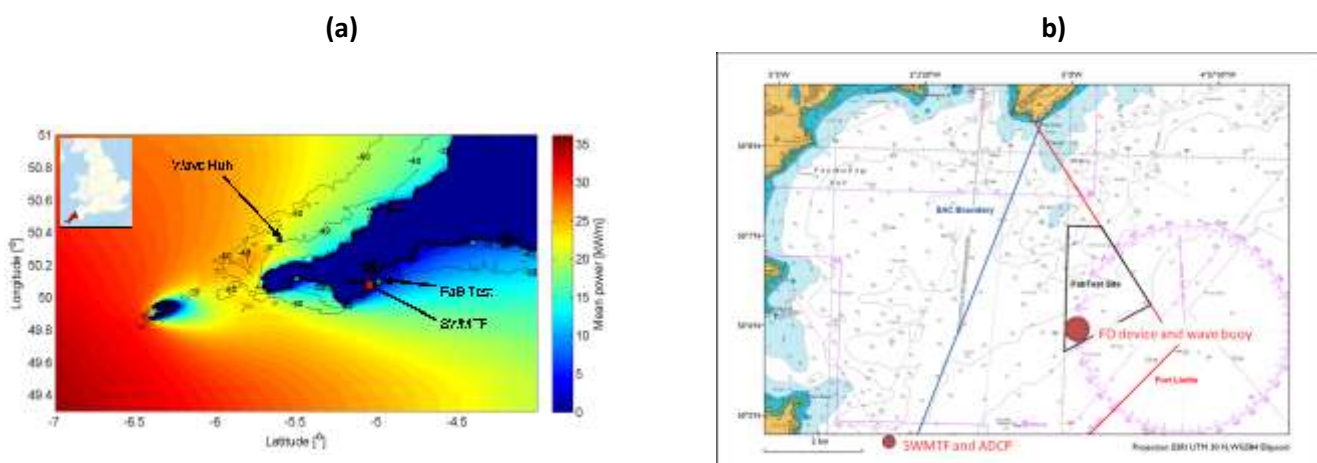

Figure 2.1 Location of SWMTF, showing mean power levels (a), adapted after [5], and bathymetry contours (b) for the Cornish coast

2.2 ENVIRONMENTAL CONDITIONS

The SWAN model indicates that wave climate with a significant wave height H_s higher than 3 m can occur with a corresponding peak period T_p of 7 to 9s. Based on the SWAN model, the yearly scatter diagram was calculated (Figure 2.2). SWAN data were updated once the Acoustic Doppler Current Profiler (ADCP) recording wave data was deployed at the facility. SWAN numerical model data and ADCP measured data correlate well with less than 7% error (Figure 2.3).

Based on tidal charts, the water depth at the site was estimated between 27 and 32.4 m, with maximum current magnitude of 0.8 m/s.

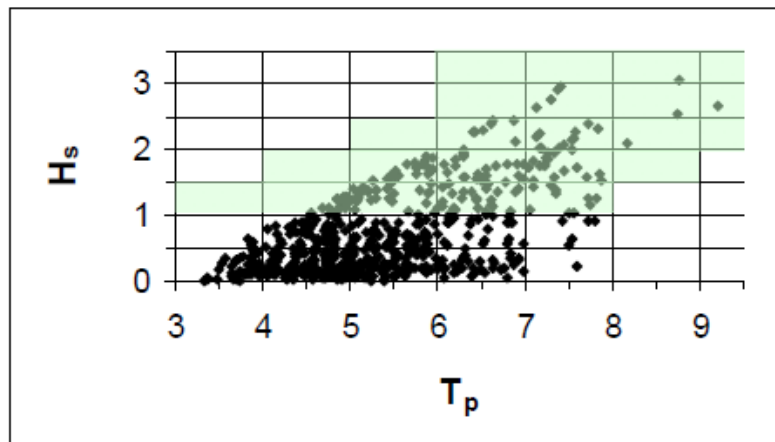

Figure 2.2 Data from the SWAN model (black diamonds) and annual wave statistics for SWMTF location (green boxes)

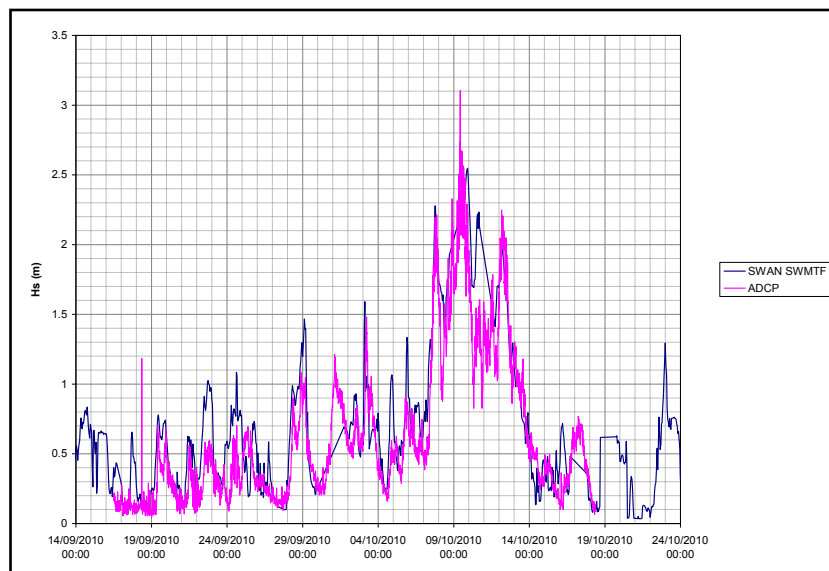

Figure 2.3 H_s from real data at SWMTF and the corresponding SWAN model output.

2.3 BUOY

An instrumented surface buoy of 3,250 kg and 2.9 m float diameter (Figure 2.4) is equipped with a DGPS, a six-degree of motion accelerometer and gyroscope, conventional in-line (axial) loadcells and specifically designed tri-axial loadcells, as well as environmental instruments monitoring wind, salinity, etc. (Figure 2.5). The BMT report [7] gives technical details about measurement tools.

The buoy has the shape of a cylinder over a truncated cone. The mechanical properties of the buoy are described in Table 2.1. The solar panels and wind turbines installed on the buoy generate energy for the acquisition system of the buoy.

The data collected by the buoy are directly transmitted to the shore using a 3G network connection at a maximum rate of 300 Kbits/sec, using an antenna.



Figure 2.4 SWMTF buoy (left: hull without top structures, right: in water)

Table 2.1 Buoy properties

Property	Value
Draft excluding load cells (including 1,500 kg mooring chains):	1,658 mm
COG	111 mm
Radius of gyration	In x, y directions: 0.5765 m In z direction: 0.7446 m
Height	3.5 m
Float diameter	2.9 m
Weight	3,250 kg

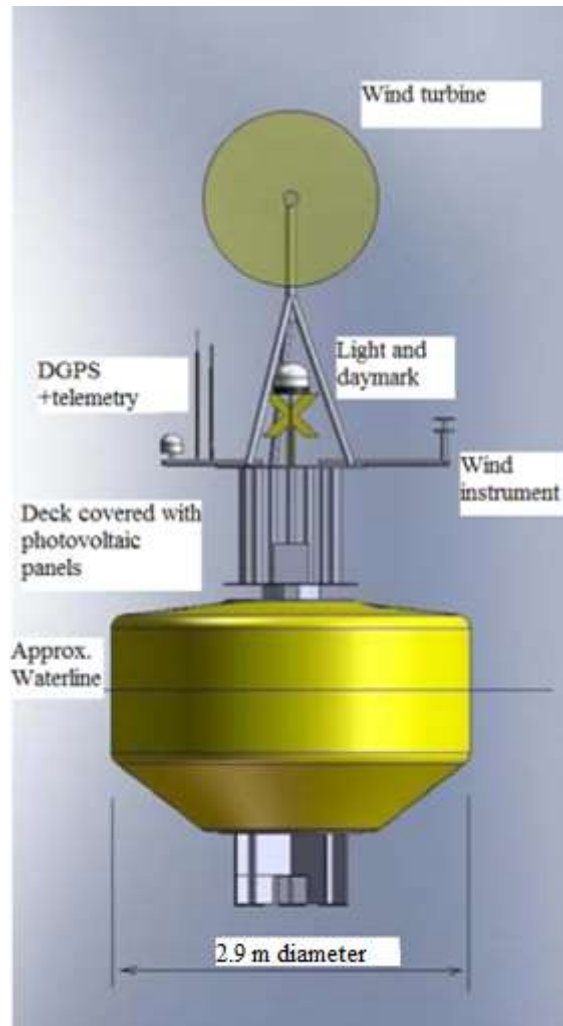

Figure 2.5 SWMTF buoy instruments

2.4 MOORING SYSTEM

A three leg catenary mooring configuration was used (Figure 2.6), where each leg was made of several elements: chains, nylon line, and connectors (Figure 2.7), as well as different drag embedment anchors (Figure 2.8). The mooring system may be changed for the future deployments: rope, anchor or other material can be tested. For example, the rope was changed after the first deployment (**Fehler! Verweisquelle konnte nicht gefunden werden.**).

The mechanical elements of the system were designed based on a 1-year return period sea state with a significant wave height H_s of 3.5 m (see section 2.2). A design load of 7 tons (~ 69 kN) was derived from a fully dynamic analysis in OrcaFlex [8]. Additionally, a target "Factor Of Safety" (FOS) of 3 was applied for the structural design to account for uncertainties. However, because of the limited availability of anchors on the market, a 1.1 tonne Danfort Bruce anchor and a 1.0 tonne Stevin anchor were used (Figure 2.7). Both anchors have respectively a slightly different FOS than the target one: the FOS of anchors 1 and 3 is 2.61 and the FOS of anchor 2 is 3.17.

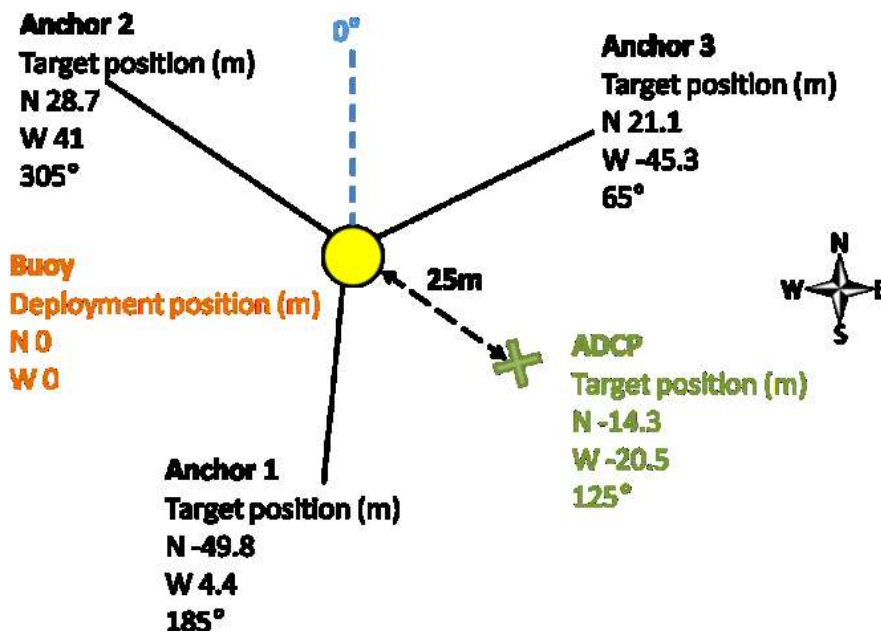

Figure 2.6 SWMTF configuration

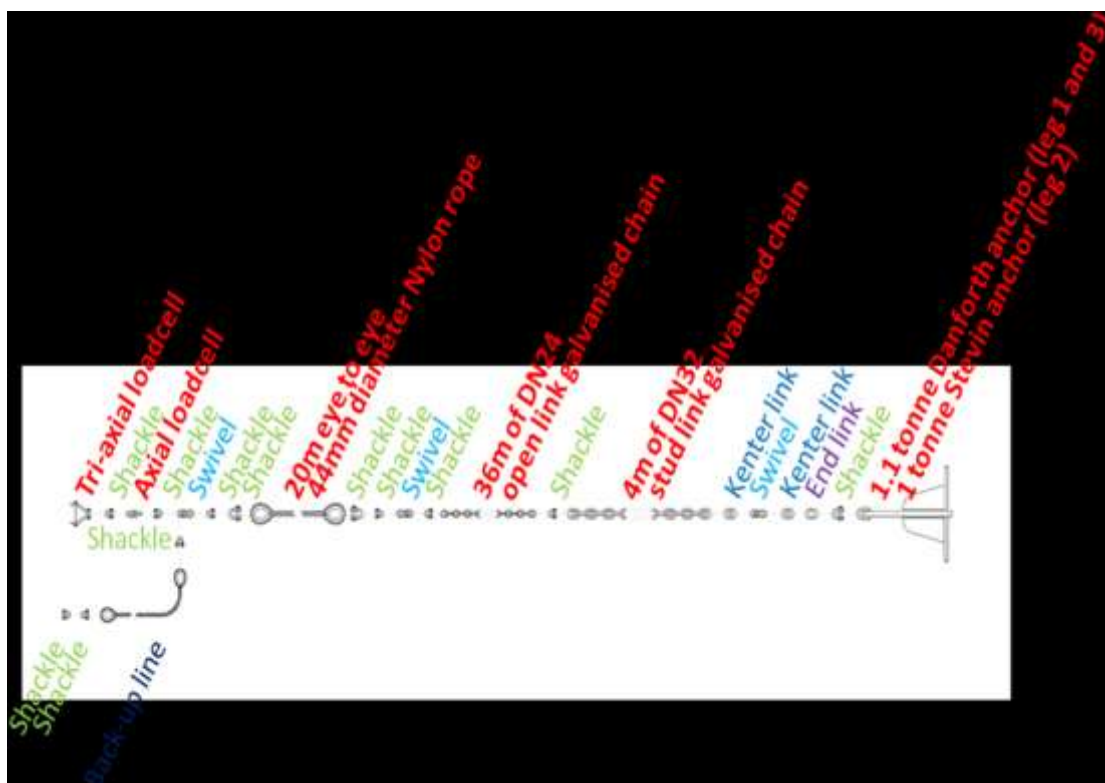

Figure 2.7 Components of a limb at SWMTF during the first deployment

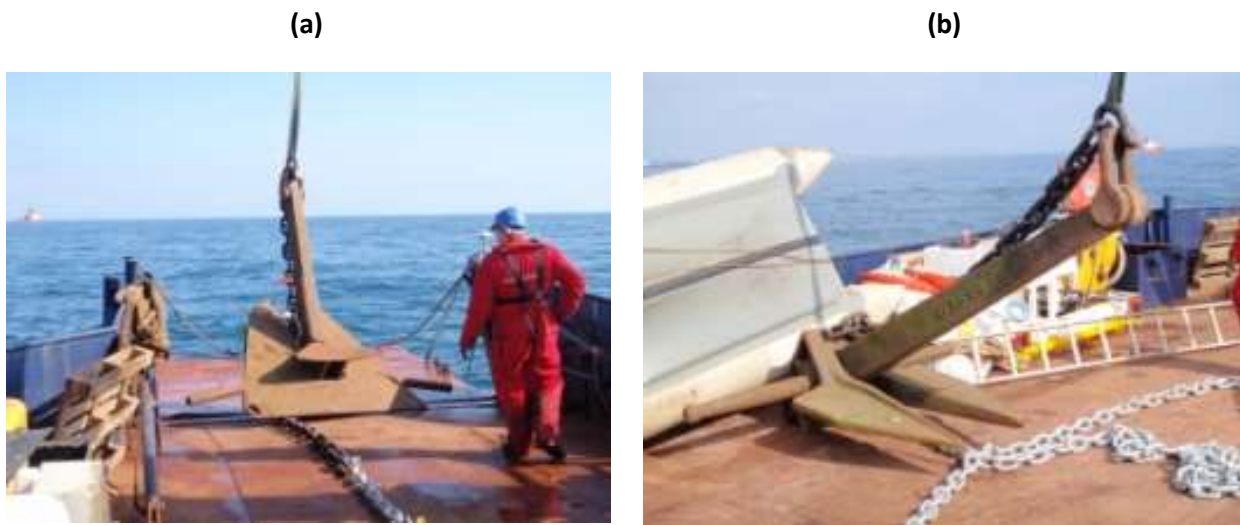



Figure 2.8 (a) Stevin anchor, (b) Danforth anchor

Table 2.2 Rope during first and second deployment

	Rope provider	Structure	Diameter (mm)	Minimum Breaking Load MBL (kN)	Axial Stiffness (kN)
First deployment	Bridon Nylon Superline	 superline	44	466	531
Second deployment	Provided by Lankhorst/built by Touwfabriek	Double braid (no jacket)	48	520	Approx 520

2.5 ADCP

A Workhorse Sentinel Acoustic Current Doppler Profiler (ADCP), equipped with 4 inclined beams was used to record wave and current data [9]. The ADCP was installed in a frame (Figure 2.9 b) on the seabed 25 m towards the SE direction in respect to the buoy equilibrium position (Figure 2.6). The ADCP was recovered at the end of each deployment of the SWMTF buoy.

The data collected by the ADCP were stored on a memory card and analysed when the ADCP was recovered. Because of its limited battery life, the ADCP was recovered approximately every three months. If a weather window was not available to recover the ADCP after 3 months of deployment, then a downtime in the ADCP data was likely. If, for some reason, the ADCP was not working during a deployment, there was no way to identify the failure of the ADCP before recovery and consequently 3 months of data were lost.

It should be noted, that the SWMTF clock and the ADCP clock are only synchronised at each ADCP deployment..

Figure 2.9 ADCP beams (a) and ADCP used at SWMTF in its frame (b)

(a)

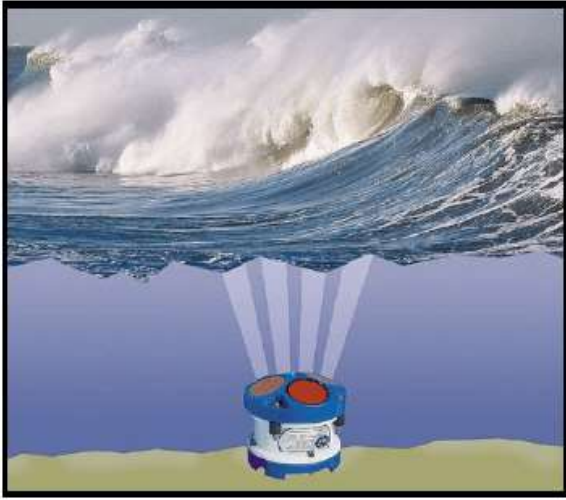

(b)



3 EQUIPMENT AND DATA COLLECTION

This section will provide an overview of the facilities instrumentation and of the data that can be collected with this measuring equipment. At the end of this section, the equipment is summarised and a summary of the operations is presented.

3.1 MEASUREMENT OF ENVIRONMENTAL CONDITIONS

The ADCP continuously records four beam elevations and water particle velocities at a sample frequency of 2 Hz in burst of 1024 points, every 1024 s or 17.06 min. This means that data are only recorded during the first half of each burst (the processing software crashed when more than 2048 points were accidentally recorded). After the recovery of the ADCP, which was retrieved approximately every 3 months, some data could be used directly and some data needed to be processed. The data which could be directly used were time series of orbital velocity, surface tracking and pressure. The primary mean of estimating directional spectra is using the orbital velocities. Surface tracking and pressure could be used for quality checks and as a back-up. For data processing the software “Wavesmon” was used. “Wavesmon” is a software package provided by the manufacturer Teledyne RDI to obtain spectral data for the significant wave height, H_s , the peak period, T_p , the associated wave direction D_p , the maximum current magnitude and the corresponding current direction in a vertical water column for each 17 minute file. The wave direction D_p is the direction where the waves are coming from, while the current direction is the direction where the current is headed. The orientation of the directions is given in Figure 3.1.

Wind, water properties and current velocity are continuously recorded by the instrumented buoy at respectively 4 Hz, 0.5 Hz and 5 Hz and saved in 10 minute files. The zero datum direction of the anemometer is set as shown in Figure 3.2. This means that if the wind blows from that zero datum direction (125° clockwise in this diagram), the anemometer will read 0°. The recorded water properties are electrical conductivity, salinity, surface temperature and density. Unfortunately, the current meter never worked.

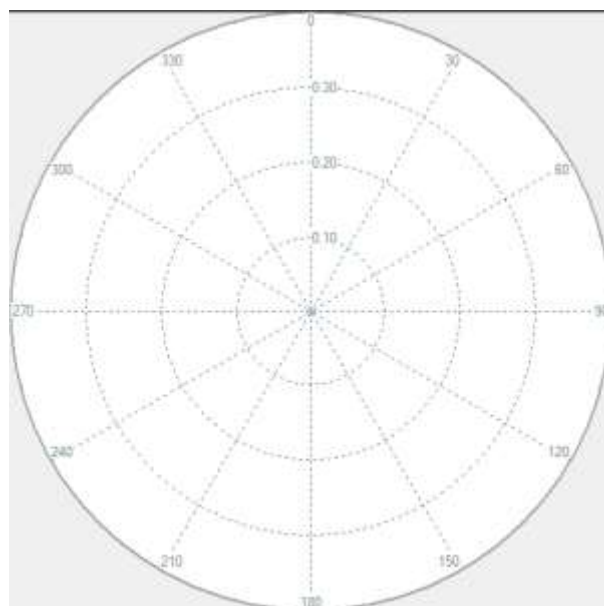

**Figure 3.1 Orientation of the wave and current direction:
0° for North, 90° for East**

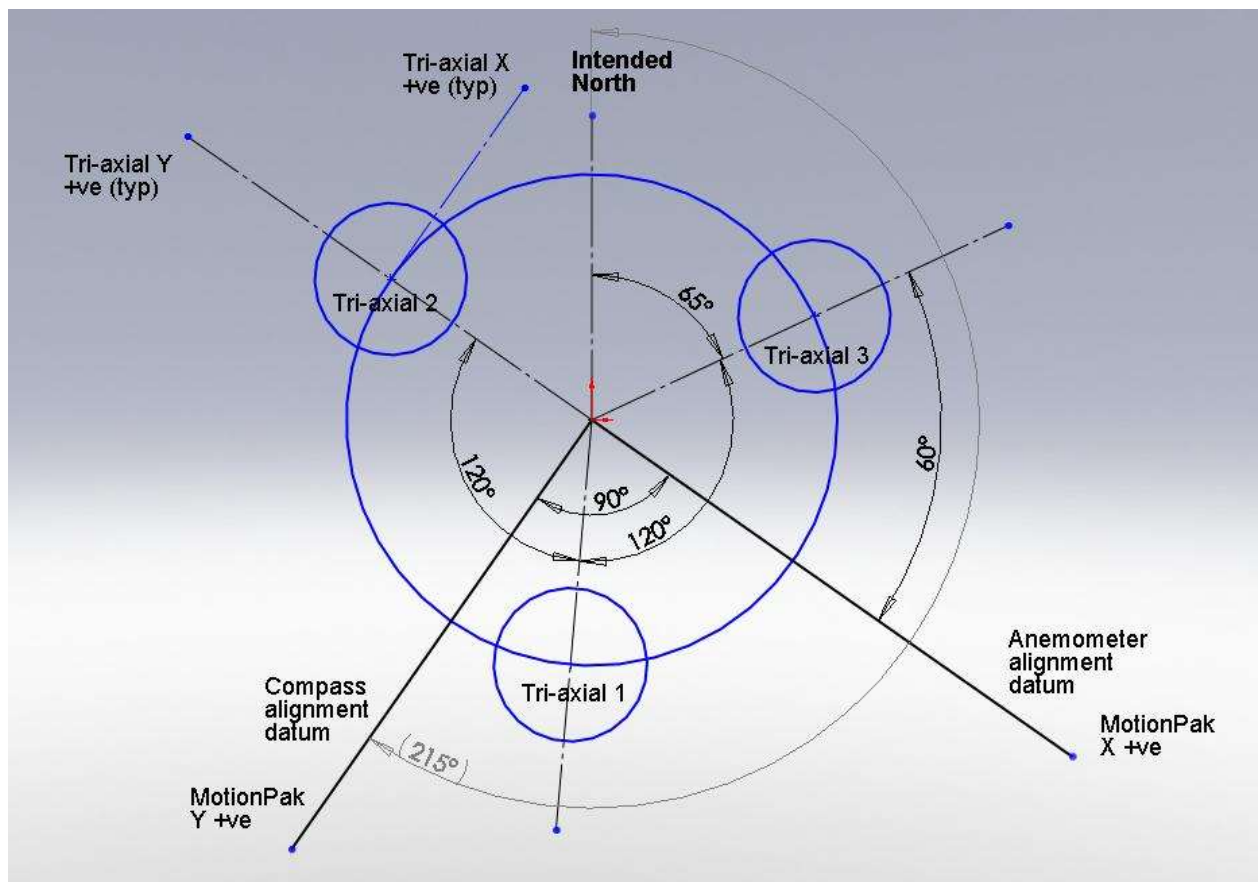

Figure 3.2 Alignment of the data of SWMTF buoy measurement tools

3.2 TENSION IN THE MOORING LINES

Mooring loadcells continuously record mooring load data at 20 Hz and save them in 10 minute files. Each mooring limb is equipped with an axial loadcell and a tri-axial loadcell (Figure 2.7, Figure 3.3). Axial loadcells have a greater accuracy than the tri-axial loadcells. They have been calibrated before use and their calibration factor is available in Table 3.1.

Each tri-axial loadcell has X, Y and Z outputs corresponding to the X and Y directions being defined in Figure 3.2. The Z axis is positive in the downward direction. These tri-axial loadcells were calibrated before use with an MTS load test machine (tensile mode) as shown in Figure 3.4. Ten loads were applied at each compound angle, and 320 compound angles in the hemisphere of operation were used. Figure 3.5 shows the multi pillar construction of a tri-axial loadcell. There is inevitable cross talk between axes (bending and pure tensile strain), but it is rational and can be calibrated out. Calibration factors are available in

Table 3.2, Table 3.3 and Table 3.4, for example $F_{xlc1} \text{ (kN)} = 66.9263V_{x1} - 0.0420V_{y1} - 0.8591V_{z1} + 2.0735$.



Figure 3.3 Tri-axial (left) and axial (right) loadcells used at SWMTF

Table 3.1 Calibration factor axial loadcells

Loadcell	Calibration factor(V/kN)
1	40581.70427
2	40699.09319
3	40870.91881

Table 3.2 Calibration factors tri-axial loadcell 1

	Fxlc1	Fylc1	Fzlc1
Vx1	66.9263	1.9330	-1.8956
Vy1	- 0.0420	66.0111	- 0.6110
Vz1	- 0.8591	- 0.3124	67.6408
constant	2.0735	1.3939	0.1399

Table 3.3 Calibration factors tri-axial loadcell 2

	Fxlc2	Fylc2	Fzlc2
Vx2	68.8288	-1.5469	0.5936
Vy2	1.9223	68.5143	1.5517
Vz2	- 0.3951	- 0.6759	68.5467
constant	- 0.0077	0.4135	0.4903

Table 3.4 Calibration factors tri-axial loadcell 3

	Fxlc3	Fylc3	Fzlc3
Vx3	71.7003	0.1425	0.1219
Vy3	0.9777	70.0384	- 0.7856
Vz3	- 0.8403	0.0757	67.7489
constant	- 0.0186	- 0.0918	- 0.56



Figure 3.4 Calibration of tri-axial loadcell

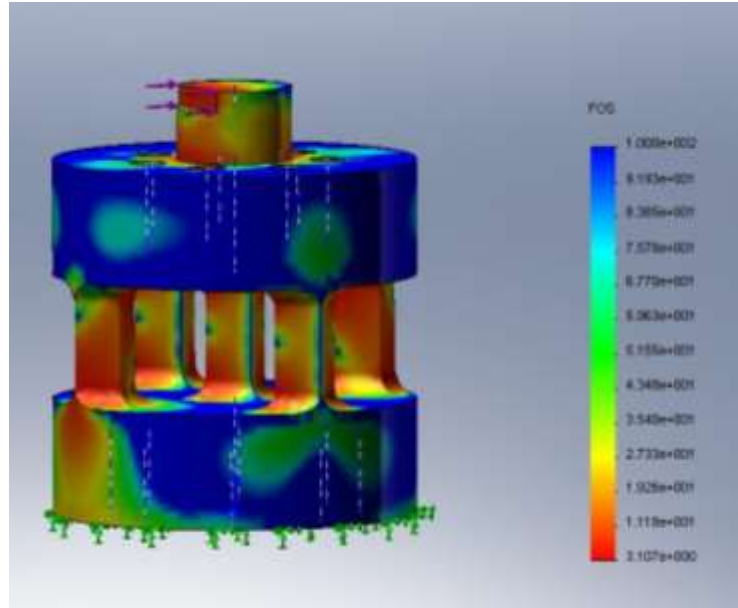

Figure 3.5 Construction of a tri-axial loadcell

3.3 MOTION OF THE FLOATING STRUCTURE

A GPS and a MotionPak inertial sensing system made of a 3 degrees of freedom (DOF) accelerometer and a 3 DOF gyroscope continuously record motion data at respectively 10 and 20 Hz and saved them in 10 minute files.

The GPS is installed on the mast of the buoy, slightly off centred (Figure 2.5). The GPS gives the absolute location of the floating structure with respect to World Geodetic System WGS84. It records positions in degree which need to be converted into position in meter. GPS correction signals from a base station at an accurately surveyed location are sent to the module using the same radio data link as for the data files. If the correction signal is received, then very high accuracy real time kinematic RTK fixes, of the order of 1 cm latitude and longitude and 2 cm in height, will be produced. The GPS clock is also used to establish the time of all the measurements from the buoy, correcting the drift of the buoy counter. This may be a problem in terms of reliability, as in case of failure of the GPS, the time will only be estimated by the counter and not corrected.

The MotionPak inertial sensing unit (Figure 3.6) sits upright on the vertical centreline of the buoy and is orientated in a way that the positive X direction aligns with the anemometer and the positive Y direction aligns with the compass as shown in Figure 3.2. The Z axis is positive in the downward direction as shown in Figure 3.6. At complete stagnation the output of the MotionPak is -9.81 m/s in the Z direction. The three gyroscope outputs are positive around their relative linear axes. The accelerometer records accelerations in g which need to be integrated twice in order to have positions in meter. The gyroscope records angular speeds in deg/s which need to be integrated once in order to have angle in degree.

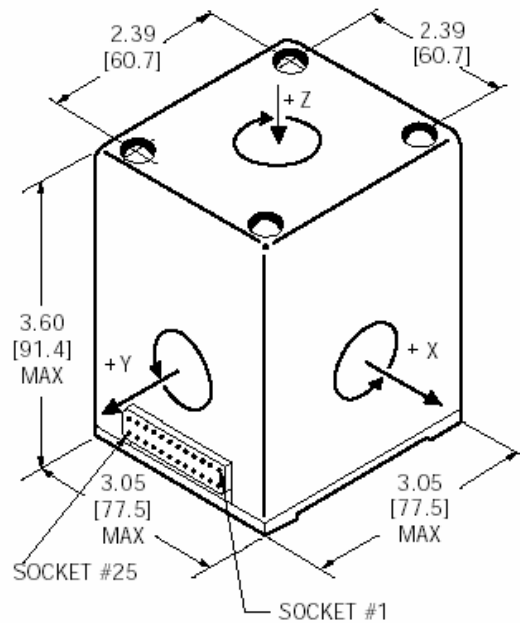

Figure 3.6 MotionPak dimensions and axis orientations







3.4 OTHER EQUIPMENT AND DATA

The buoy is equipped with some other instruments and save their data every 10 minutes (all data recorded on the buoy are synchronised and saved for the same 10 minute periods). Strain gauges measure strain at 20 Hz and are installed on the hull. A compass measured heading at 20 Hz (Figure 3.2). Power input is monitored at 1 Hz. A counter records the time in milliseconds at which data are recorded. The counter runs from 1 to $2^{16}-1$ ms. Due to a possible drift of the counter or delay between the recording and the saving time, the GPS time was used instead of the counter time for further analysis.

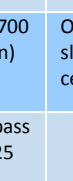
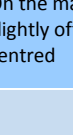
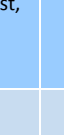
3.5 SUMMARY OF THE INSTRUMENTATION

Table 3.5 summarises the equipment which is installed at SWMTF.

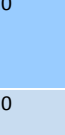
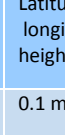
Table 3.5 Instrumentation

Data	Tool	Location of the tool	Picture	Frequency (Hz)	Resolution	Range
In-line loads	3 axial loadcells: Elite 10062	Between a triaxial loadcell and a limb		20	1 kg	0-7 te
Tri-axial loads	3 tri-axial loadcells: Elite 10073	Under the buoy		20	1 kg	0-7 te except in the z direction: 0-14 te
Hull strain Vishay CEA-06-250UR-350	6 strain gauges	On top of the hull		20	1 $\mu\epsilon$	+/-100 $\mu\epsilon$
6DOF: 3 accelerations, 3 angular speed	MotionPak inertial sensing system	Centre of the buoy		20	acceleration: 0.001 g, angular speed: 0.01 deg/s	+/- 2 g in the x and y direction, +/- 3 g in the z direction, +/- 50 deg/s for the roll and pitch, +/- 30 deg/s for the yaw
GPS position	GPS Trimble 5700 (RTK correction)	On the mast, slightly off centred		10	Latitude, longitude: +/- 1 cm, height: +/- 2 cm	-
Compass orientation	flux gate compass Autonnic A4025 OEM			20	0.1 magnetic deg	0-360deg
Wind speed and direction	Sonic anemometer: Gill Windsonic	On the mast, slightly off centred		4	Speed: 0.1 m/s, direction: 1 deg	Speed: 0-60 m/s, direction: 0-360 deg
Water current (X and Y direction) and temperature	Aanderaa 4100 DCS			5	Current: 0.001m/s, temperature: 0.1 °C	Current: +/- 3m/s, temperature: +/- 90 °C
Water properties	Aanderaa 4120 IW			0.5	water conductivity: 0.01 mS/cm, water temperature: 0.1 °C, water salinity: 0.01ppt, water density: 0.01kg/m3	water conductivity: 40-60mS/cm, water temperature: 0-20 °C, water salinity: 20 to 50ppt, water density: 990-1030kg/m3
Power Supply	Internal sensors			1	+/- 0.1V	
Internal temperature and humidity	Internal sensors PRT 100 Ω TDK CHS-UGR			1	Temperature: +/- 0.1 °C, humidity: 1%	Temperature: 10-90 °C, Humidity: 0-95%
Beam elevation and current	ADCP Teledyne RDI Workhorse Sentinel (600 kHz) ADCP with Waves Array firmware	Seabed, in the footprint of the mooring		2	Velocity: 0.1 cm/s	Velocity: +/- 5 m/s (default) Min observable wave period: <ul style="list-style-type: none"> Non-directional wave: 2.88 s Directional wave: 4.85 s

3.6 SUMMARY OF THE OPERATIONS

Table 3.6 summarises the operations at SWMTF. It indicates when data were recorded or when failures occurred.

Table 3.6 Summary of SWMTF operations

Date	Comments
14/03/10	FIRST DEPLOYMENT: Buoy and mooring deployed
16/08/10	Buoy instrumentation working and data recoverable
16/09/10	ADCP deployed: Facility fully working
18/10/10	ADCP recovered and redeployed
10/12/10	ADCP recovered and redeployed
09/03/11	ADCP recovered and redeployed
15/06/11	ADCP recovered. Failure of redeployed ADCP
08/09/11	GPS failure
13/10/11	ADCP recovered
25/10/11	Buoy brought back to shore
06/02/12	Mooring removed
23/08/12	SECOND DEPLOYMENT: Buoy and mooring redeployed
03/09/12	Buoy instrumentation working and data recoverable
20/09/12	ADCP deployed Buoy acquisition system damaged
06/11/12	New data module installed Buoy instrumentation working and data recoverable
18/12/10	ADCP recovered and redeployed
08/01/13	DGPS not available but GPS still available
08/02/13	Facility working and data recoverable

4 FIELD MEASUREMENT

Some examples of measurements will be shown in this section: time-series and a summary over several days. The time series were taken on 16/11/2010 between 01:00 and 01:10 (calm sea state) and on 17/11/2010 between 02:08 and 02:10 (storm). For the summary, data between 15/11/2010 and 20/11/2010 are used.

4.1 MARINE ENVIRONMENT DATA

4.1.1 Wave

TIME SERIES

Only half of the surface elevation data of each 17 minutes burst was recorded. A large number of errors in the surface elevation measurements can be observed during a calm sea state (Figure 4.1 left), with the data jumping to zero.

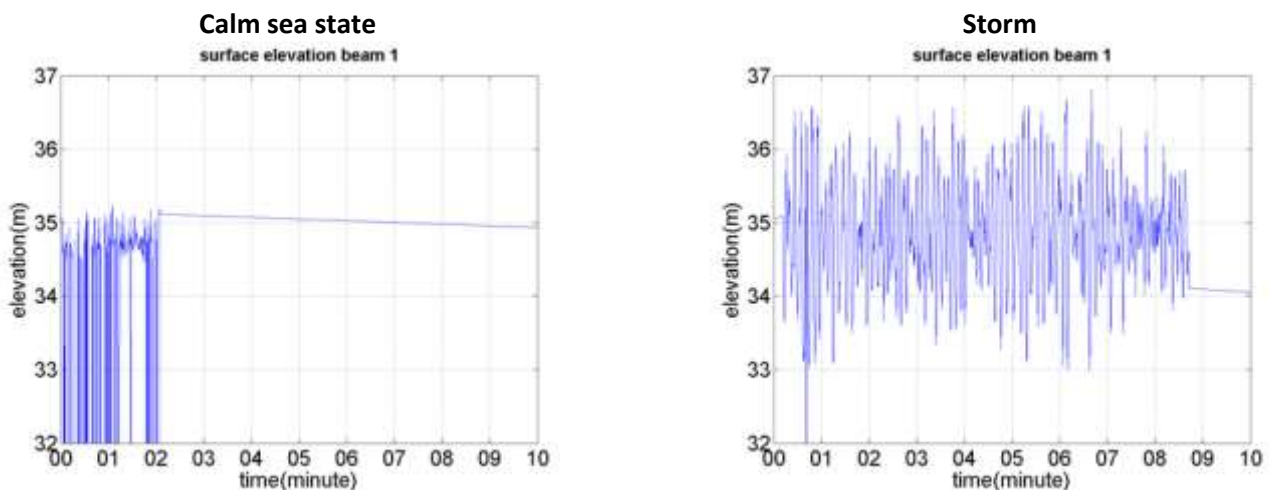

Figure 4.1 Surface elevation measurements for 10 minutes

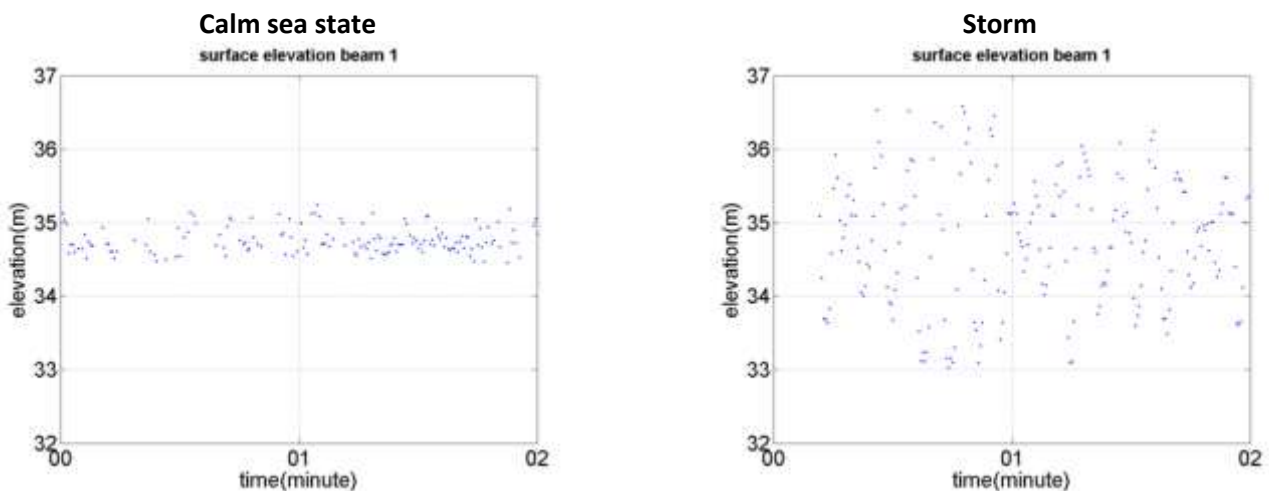

Figure 4.2 Surface elevation measurements for 2 minutes (not the same time as for following pictures)

SUMMARY

The wave statistical data T_p (Figure 4.3) show some dispersion for low H_s . Indeed, the ADCP is not accurate for H_s below 0.5 m [10].

Once these statistical data have been calculated, tools such as scatter diagram (Figure 4.4) or wave rose (Figure 4.5) can be used to summarise the wave data from the whole deployment. The summary of the environmental data can then be compared with the summary of mooring loads or buoy positions.

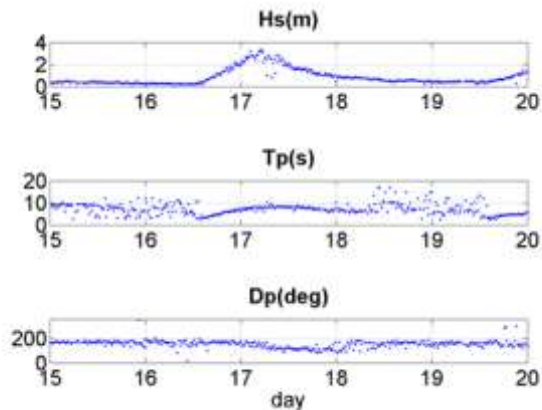

Figure 4.3 Summary of wave conditions

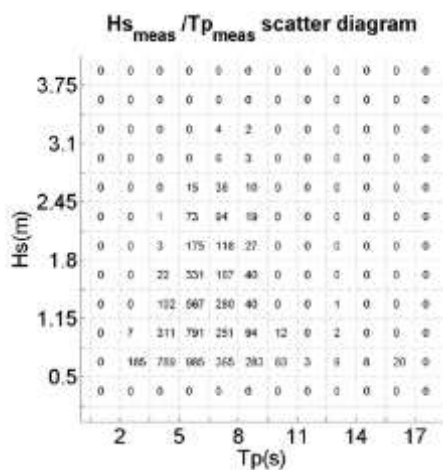

Figure 4.4 Scatter diagram at SWMTF based on first deployment

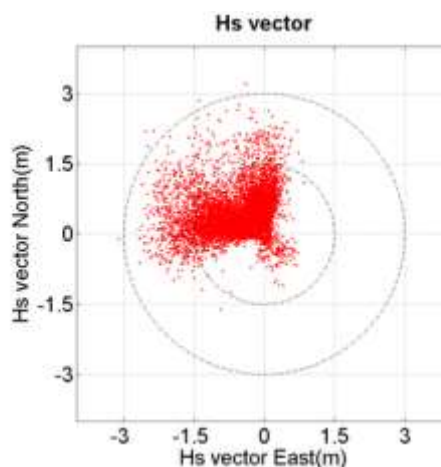

Figure 4.5 Wave rose at SWMTF based on first deployment

4.1.2 Tidal

SUMMARY

Based on the plots of current magnitude and direction through time (Figure 4.6), a surface layer can be identified in the current profile. This red/burgundy layer can clearly be observed between 25 and 30 m in Figure 4.6. This is due to the ADCP side lobe reflections of the acoustic beams [11]). Consequently, current magnitude and direction should be chosen below this surface layer for further analysis. The magnitude used for further investigations has been chosen as the maximum magnitude below the surface layer and the current direction the direction associated with this maximum magnitude. A tidal rose (Figure 4.7) can be used to summarise the current measurements.

The summary of the water depth variations (Figure 4.8) needs to be compared with the variations in tension of the mooring lines, because high water depths will increase the pretension of the mooring system and change its dynamic behaviour [12].

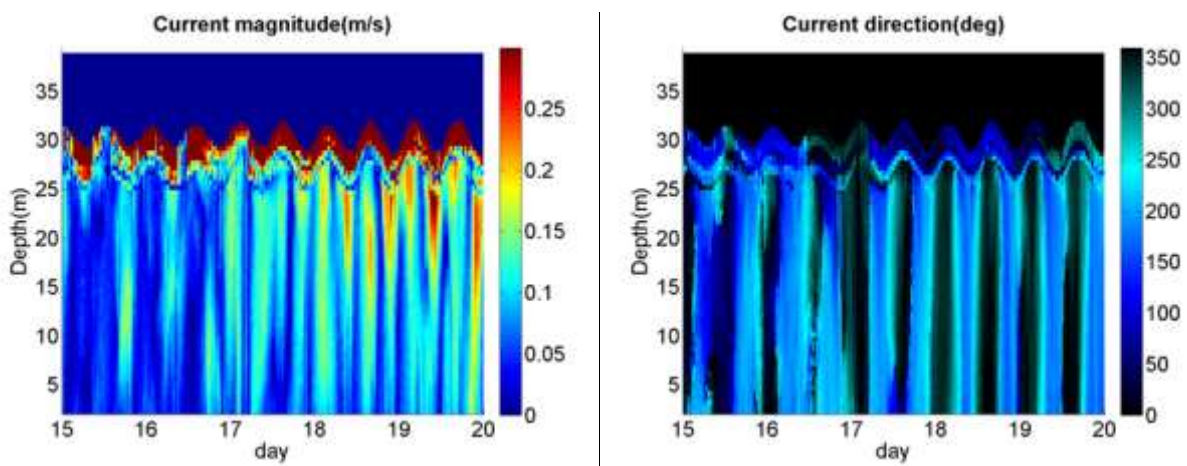

Figure 4.6 Summary of current measurements at SWMTF: magnitude and direction

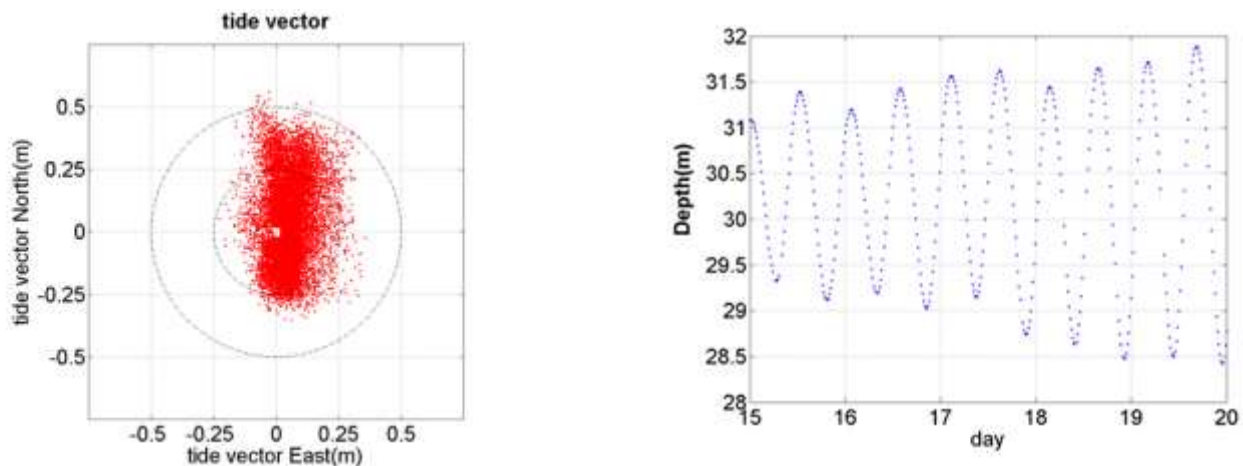

Figure 4.7 Tidal rose at SWMTF based on first deployment

Figure 4.8 Summary of water depth

4.1.3 Wind

TIME SERIES

As expected, time series of wind speed and direction (Figure 4.9) shows more variability during a storm than during a calm sea state.

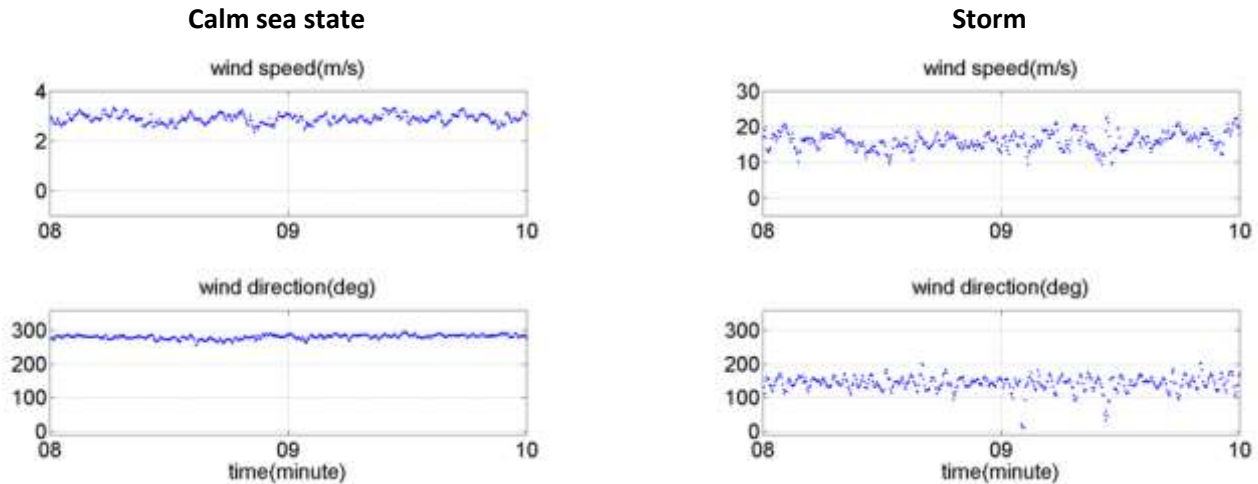

Figure 4.9 Wind measurement time series

SUMMARY

The summary of the wind speed data (Figure 4.10) can be compared with the summary of the wave statistical parameters. In order to calculate the mean wind direction, the average of each 10 minute record of time series of wind data cannot be calculated directly. The averages of the cosines and sines of the angle can be calculated. The average angle is then obtained as the arctan of the mean of the sines divided by the mean of the cosines.

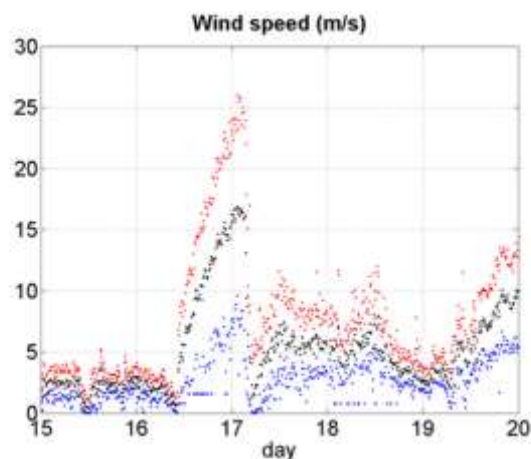

Figure 4.10 Summary of wind speed. The maximum (red), mean (black) and minimum (blue) wind speeds are plotted

4.1.4 Water properties

Time-series (Figure 4.11) and summary (Figure 4.12) of water properties can be used by biologists for environmental surveys. For example, the underwater speed of sound can be calculated using these measurements.

TIME SERIES

The water properties are slowly varying as shown in Figure 4.11.

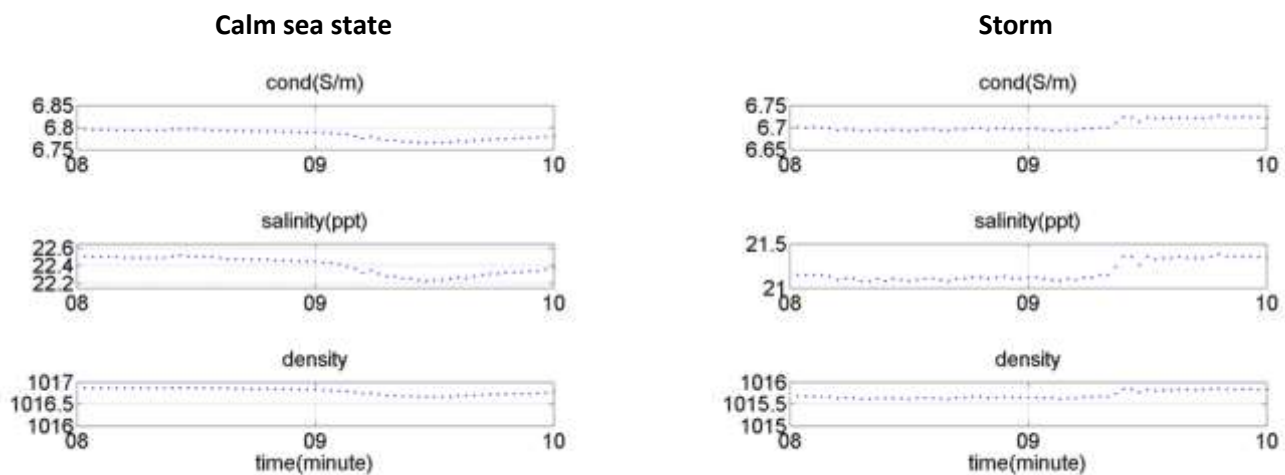

Figure 4.11 Water property measurements

SUMMARY

An example of the long term variations of the water properties is given in Figure 4.12. The conductivity, salinity and density are similarly varying, indicating relationships between these parameters.

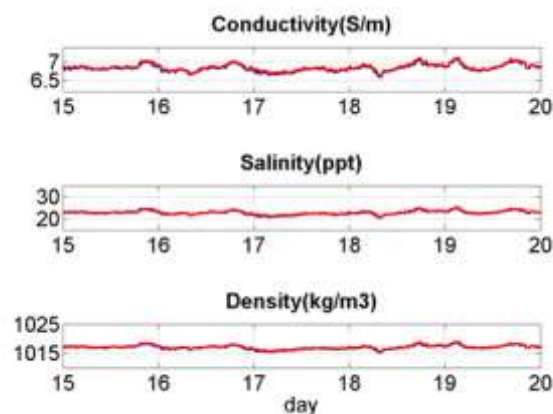

Figure 4.12 Summary of water properties

4.2 MOORING LOAD

TIME SERIES

Time series of mooring load data shows mooring loads with an high amplitude suddenly occurring during storm (Figure 4.13). These data can be compared with a numerical model in order to get more understanding of the dynamics of mooring systems.

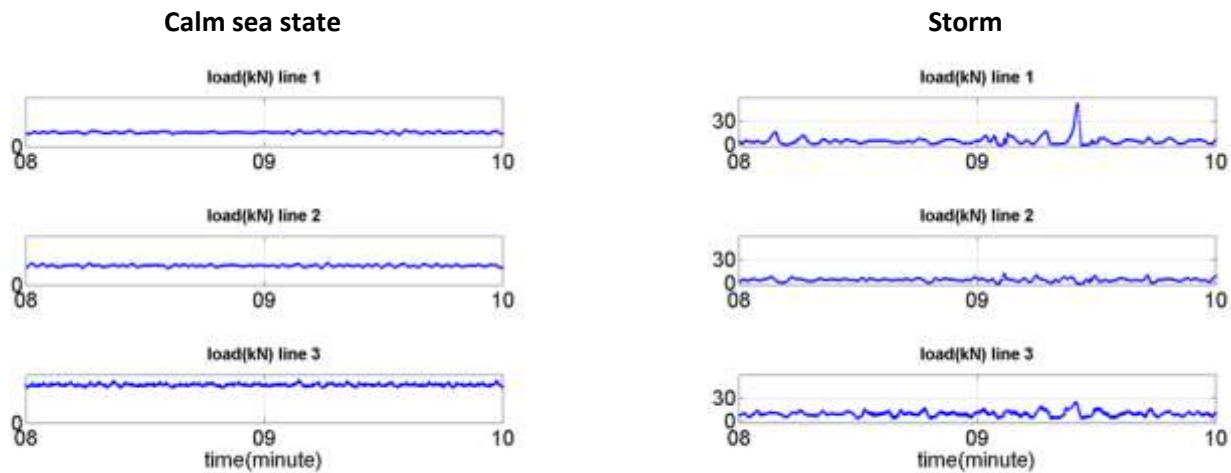

Figure 4.13 Mooring axial load measurements

SUMMARY

The average of the mooring load summary data (Figure 4.14 black points) can be used to estimate the pretension of the mooring system and calibrate the numerical model. The maximum of the summary data (red points) can be used to relate extreme mooring loads with environmental conditions, and determine which environmental conditions put the mooring system at risk.

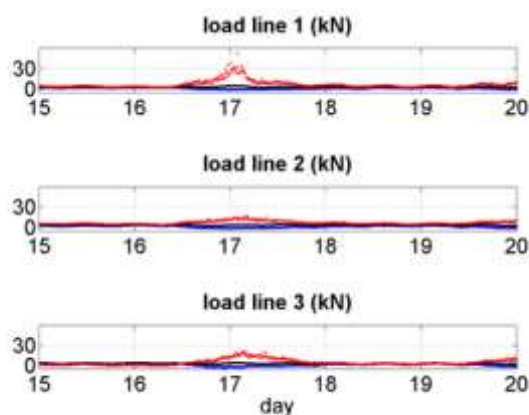

Figure 4.14 Summary of mooring axial load measurements. The red points show the maximum load, the black points the mean load and the blue points the minimum load.

4.3 MOTION

TIME SERIES

Time-series of buoy motions indicate large motions during storm. These data can be compared with a numerical model in order to get more understanding of the dynamics of mooring systems.

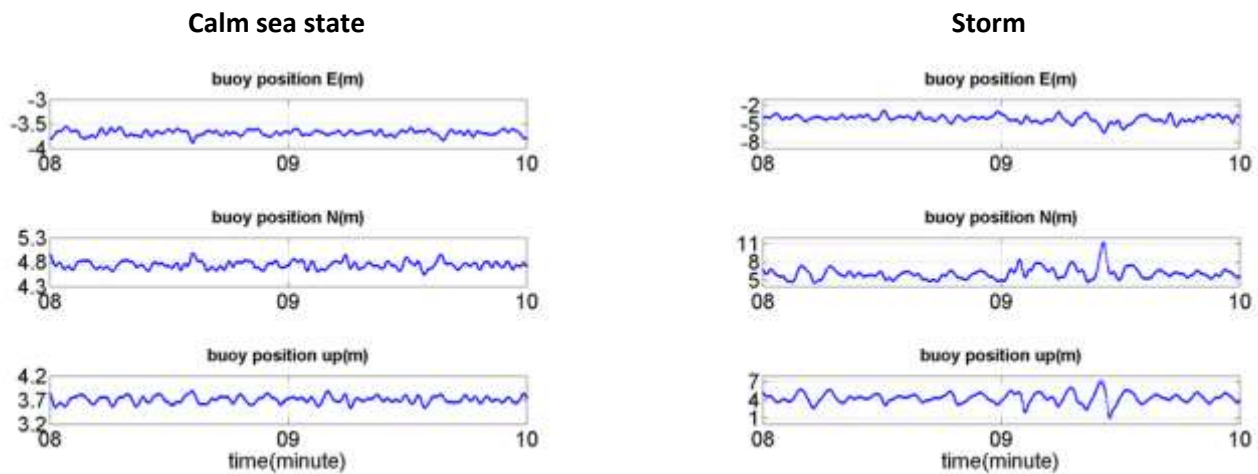

Figure 4.15 Buoy motion measurements

SUMMARY

The average of the mean position (black points) should be used to calibrate the numerical model. These data can be used to monitor the position of the buoy in real time and detect any problem: anchor drag, line failure or buoy disconnection.

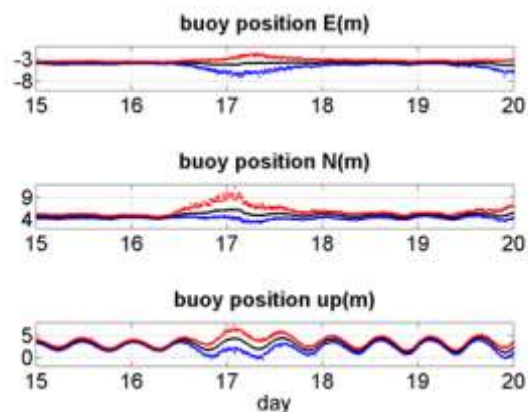

Figure 4.16 Summary of buoy motion measurements. The red line shows the maximum value, the black line the mean value and the blue line the minimum value.

5 RESEARCH FINDINGS

The SWMTF is used to improve the understanding of extreme mooring loads. In particular, a study has been done to compare peak mooring loads and the associated environmental conditions.

First, the percentage of occurrences of H_s/T_p at SWMTF is calculated (Figure 5.1(a)), by dividing the values in the scatter diagram (Figure 4.4) by the sum of all values in this scatter diagram. Then contour lines are added (Figure 5.1 (b)) in order to have a graphic representation of the scatter diagram.

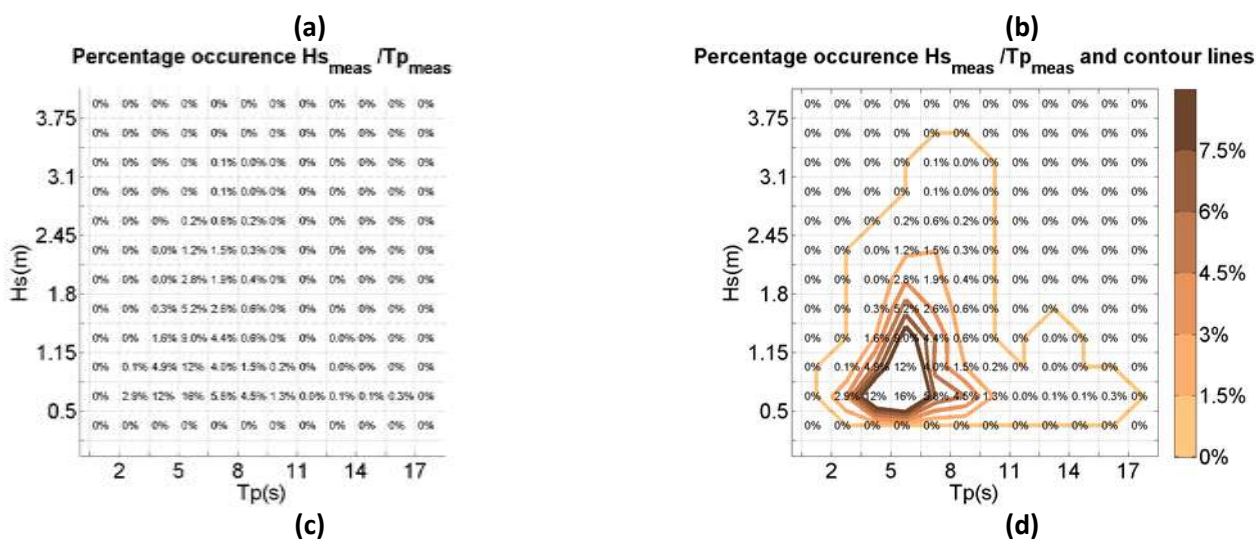

Figure 5.1 Percentage of occurrences of H_s/T_p (a) and contour plot of H_s/T_p (b)

Then, peak mooring loads are detected and their corresponding environmental conditions are recorded (Figure 5.2 (a)). These environmental conditions are then used to plot contour lines (Figure 5.2(b)) which indicates which percentage of occurrence was associated with a given sea state during field tests. The envelope of all environmental conditions recorded at SWMTF (Figure 5.1 (b)) is plotted with a dotted contour line.

Aim of this research is to investigate if oil and gas standards, such as DNV OS E301 **Fehler! Verweisquelle konnte nicht gefunden werden.**, which have been developed for large structures mainly induced by Low Frequency excitations, are appropriate for small floating structures such as Marine Renewable Energy (MRE) devices, which are responding to first order Wave Frequency forces. The results of this study indicate that peak mooring loads occur for values inside the scatter diagram, and not at its limits (Figure 5.2(b)).

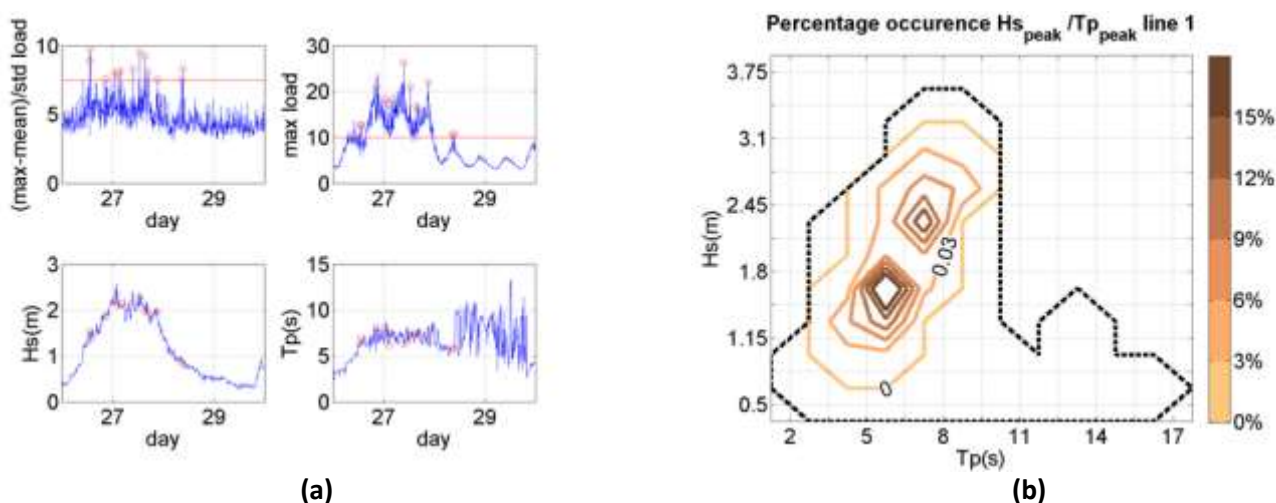

Figure 5.2 Methodology: (a) example of detection of peak mooring loads. Red circles indicate detected peak mooring loads and corresponding environmental conditions, with standard score $> K$ and maximum load $> \tau$, (b) contour plot corresponding to these environmental conditions

6 CONCLUSIONS AND RECOMMENDATIONS

This report details the equipment which is currently in use at the SWMTF, and provides examples of measurements and ongoing research. This facility is unique in the MARINET network, and focuses on one of the last step of development of a MRE device: field tests. Other facilities are available through the network and will provide information about earlier steps such as D4.1 “Report on tank test related instrumentation and best practice”. Particular problems will be studied in D4.4 “Report on low frequency response and moorings”.

The SWMTF project is a global project which requires knowledge in several different fields, such as wave and tidal measurements. This knowledge can be provided by the other MARINET deliverables:

- D2.1: Wave instrumentation database
- D2.5: Instrumentation best practices
- D2.7: Tidal Measurement Best Practice Manual
- D2.9: Standards for Wave Data Analysis, Archival and Presentation

The results from this facility combined with the results of the other MARINET partners will allow providing guidelines and best practices for the development of MRE devices.

7 REFERENCES

- [1] Harnois, V., Parish D., Johanning, L., 2012. Physical measurement of a slow drag of a drag embedment anchor during sea trials, in Proc. of the 4.th Int. Conf. On Ocean Energy (ICOE), Dublin, Ireland
- [2] Johanning, L., Smith, G.H., Bullen, C., 2007. Large scale mooring line experiments and comparison with a fully dynamic simulation program with importance to MEC installation, in Proc. Of the 17th International Offshore and Polar Engineering Conference (ISOPE), Lisbon, Portugal
- [3] P.R. Thies, L. Johanning; V. Harnois; H.C. Smith; D.N. Parish. (2013) Mooring line fatigue damage evaluation for floating marine energy converters: Field measurements and prediction, Renewable Energy, volume 63, pages 133-144, DOI:10.1016/j.renene.2013.08.050.
- [4] Delft University of Technology, 2012. SWAN User Manual. http://swanmodel.sourceforge.net/online_doc/swanuse/swanuse.html
- [5] Van Nieuwkoop, J.C., Smith, H. C., Smith, G.H., Johanning, L., 2012. Application and evaluation of a long term hindcast dataset for wave resources and extreme wave conditions on the Cornish coast. Renewable Energy In press.
- [6] Smith, H., Ashton, I., Van Nieuwkoop, J.C., Parish, D., Johanning, L., 2012. Wave resource assessment for the Falmouth Bay marine energy test site (Fabtest), in: Proc. of the 4.th Int. Conf. On Ocean Energy (ICOE), Dublin, Ireland
- [7] Brent Measurement Technology , 2010. Mooring test facility. The electronics module. Operation manual.
- [8] Orcina. (2007). OrcaFlex User Manual, Version 9.5a
- [9] TELEDYNE RD Instruments, 2008. Workhorse waves array. Directional wave measurement option for workhorse ADCPs.
- [10] Herbers, T. H. C., Lentz, S. J., 2010. Observing Directional Properties of Ocean Swell with an Acoustic Doppler Current Profiler (ADCP). *Journal of Atmospheric and Oceanic Technology* 27:1, 210-225
- [11] RD Instruments, 1996. Acoustic Doppler Current Profiler. Principles of operations. A practical Primer
- [12] Johanning, L., Smith, G.H., Wolfram J., 2007(b). Measurements of static and dynamic mooring line damping and their importance for floating WEC devices, *Ocean Engineering* 34, 1918-1934